



INSTRUCTIONS FOR METAL CUTTING BANDSAW

MODEL NO: **SM355CE**

Thank you for purchasing a Sealey product. Manufactured to a high standard, this product will, if used according to these instructions, and properly maintained, give you years of trouble free performance.

IMPORTANT: PLEASE READ THESE INSTRUCTIONS CAREFULLY. NOTE THE SAFE OPERATIONAL REQUIREMENTS, WARNINGS & CAUTIONS. USE THE PRODUCT CORRECTLY AND WITH CARE FOR THE PURPOSE FOR WHICH IT IS INTENDED. FAILURE TO DO SO MAY CAUSE DAMAGE AND/OR PERSONAL INJURY AND WILL INVALIDATE THE WARRANTY. KEEP THESE INSTRUCTIONS SAFE FOR FUTURE USE.



Refer to instruction manual



Wear protective gloves



Wear eye protection



Wear face mask



Wear ear protection



Wear protective clothing



Indoor use only



Wear Safety footwear

1. SAFETY

1.1. ELECTRICAL SAFETY

- WARNING!** It is the user's responsibility to check the following:

Check all electrical equipment and appliances to ensure that they are safe before using. Inspect power supply leads, plugs and all electrical connections for wear and damage. Sealey recommend that an RCD (Residual Current Device) is used with all electrical products. You may obtain an RCD by contacting your local Sealey dealer. If the product is used in the course of business duties, it must be maintained in a safe condition and routinely PAT (Portable Appliance Test) tested.

Electrical safety information: it is important that the following information is read and understood.

- 1.1.1. Ensure that the insulation on all cables and on the appliance is safe before connecting it to the power supply.
- 1.1.2. Regularly inspect power supply cables and plugs for wear or damage and check all connections to ensure that they are secure.
- 1.1.3. **Important:** Ensure that the voltage rating on the appliance suits the power supply to be used and that the plug is fitted with the correct fuse - see fuse rating in these instructions.
 - × **DO NOT** pull or carry the appliance by the power cable.
 - × **DO NOT** pull the plug from the socket by the cable.
 - × **DO NOT** use worn or damaged cables, plugs or connectors. Ensure that any faulty item is repaired or replaced immediately by a qualified electrician.
- 1.1.4. This product is fitted with a BS1363/A 13 Amp 3 pin plug.

If the cable or plug is damaged during use, switch the electricity supply and remove from use. Ensure that repairs are carried out by a qualified electrician.

Replace a damaged plug with a BS1363/A 13 Amp 3 pin plug. If in doubt contact a qualified electrician.

A) Connect the GREEN/YELLOW earth wire to the earth terminal 'E'.
B) Connect the BROWN live wire to the live terminal 'L'.
C) Connect the BLUE neutral wire to the neutral terminal 'N'.

Ensure that the cable outer sheath extends inside the cable restraint and that the restraint is tight. Sealey recommend that repairs are carried out by a qualified electrician.
- 1.1.5. Cable extension reels. When a cable extension reel is used it should be fully unwound before connection.
- 1.1.6. A cable reel with an RCD fitted is recommended since any product which is plugged into the cable reel will be protected. The section of the cable on the cable reel is important. We recommend that at least 1.5mm² section cable but to be absolutely sure that the capacity of the cable reel is suitable for this product and for others that may be used in the other output sockets, we recommend the use of 2.5mm² section cable.

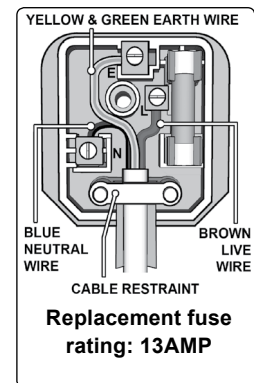

1.2. GENERAL SAFETY

- WARNING!** Disconnect the bandsaw from the power source before servicing, changing accessories, or performing any other maintenance.
- ✓ Familiarise yourself with the applications and limitations of the bandsaw, as well as the potential hazards.
- ✓ Maintain the bandsaw in top condition. Keep it clean and keep blades sharp for best and safest performance.
- ✓ Use original Sealey spare parts only. Unauthorised parts may be dangerous and will invalidate the warranty.
- ✓ Keep all guards and fixing screws in place, tight and in working order. Check regularly for damaged parts. A guard or any other part that is damaged must be repaired or replaced before the saw is used further. Check also for incorrect alignment of moving parts, loose mountings, or any other condition that could affect the operation of the saw.
- ✓ Ensure the space allocated for use and maintenance of the bandsaw is adequate, free from unrelated materials and has good lighting.
- ✓ Wear approved eye and ear protection when operating the bandsaw. If dust is produced, wear an approved face or dust mask.
- ✓ Keep children and unauthorised persons away from the work area, especially when the saw is in operation.
- ✓ Remove any adjusting keys and wrenches from the bandsaw before operating.
- ✓ Ensure that large or oversized workpieces are supported at bed height. Ensure you use a suitable support for any workpiece that does not have a flat surface. Be cautious when cutting workpieces which are irregular in cross-section as the saw blade could be pinched before the cut is completed. Any stock such as frame moulding, must lay flat on the table surface and not be allowed to rock.
- WARNING!** Round bar and tubing have a tendency to roll while being cut and cause the blade to "bite". **DO NOT** cut such items without clamping or blocking the workpiece.
- WARNING!** Never force the blade through the workpiece.
- × **DO NOT** use this bandsaw for anything other than its intended purpose. This bandsaw is designed for metal cutting work in engineering workshops, garages, metal fabricators, etc.
- WARNING!** The SM355CE bandsaw **MUST NOT** be used to cut non-metallic materials (including wood). To do so will invalidate your insurance cover and your warranty and may cause damage and/or personal injury.

- ✗ **DO NOT** wear loose or ill-fitting clothing. Remove ties, watches, rings and other jewellery. Tie up, or adequately cover, long hair.
- ✗ **DO NOT** start the bandsaw until the workpiece is secure and the blade has been lowered to just above the workpiece.
- ✗ **DO NOT** run the bandsaw with the blade in the raised position.
- ✗ **DO NOT** use the bandsaw in areas where fumes from paint, solvents, or flammable liquids pose a potential hazard. Keep all flammable materials (including wipes or cleaning rags) away from the saw, and dispose of according to local regulations.
- ✗ **DO NOT** leave the bandsaw running unattended. Turn power switch 'Off' and **DO NOT** leave area until the blade has come to a complete stop.
- ✗ **DO NOT** use whilst under the influence of drugs, alcohol or other intoxicating medication.
- ✗ **DO NOT** use the bandsaw with the blade guards or bow rear cover removed.
- ✗ **DO NOT** stand on the bandsaw.
- ✗ **DO NOT** use damaged or deformed bandsaw blades.
- ✗ **DO NOT** use the bandsaw in wet or damp locations.
- ✗ **DO NOT** use the bandsaw if you are fatigued.
- ✓ Turn the bandsaw **OFF** before raising the blade.
- ✓ Wear protective gloves when handling workpiece and saw blades.
- ✓ Always secure the workpiece in the vice.
- ✓ Keep correct footing and balance at all times and wear non-slip shoes with steel toe caps.

2. INTRODUCTION

Manufactured to comply with Safety of Machinery (Safety) Directives 1992 (and amendments) and fully CE approved. Saw arms are fitted with hydraulic damping to prevent the arm being dropped onto the workpiece and to ensure smooth cutting performance. Bow rotates up to 60° angle allowing workpiece to always sit in a central position. Coolant fluid system and main power controls are switched on individual 24V/230V circuits for extra safety. Features auto and manual shut-off switches giving the user options of control when in use. Heavy-duty single phase electric motor.

3. SPECIFICATION

Model No:	SM355CE
Capacity 60° - Round:	Dia 90mm
Capacity 60° - Square:	85mm
Capacity 45° - Round:	Dia 150mm
Capacity 45° - Square:	145mm
Capacity 0° - Square:	150mm
Capacity 0° - Round:	Dia 220mm
Capacity 0° - Rectangle (H x W):	260 x 150mm
Blade Size:	2450x27x0.9mm
Blade Speed:	72mtr/min
Coolant Pump Power:	25W
Motor Power:	1100W
Supply:	230V
Overall Size (W x D x H):	1720 x 800 x 1810mm
Weight Nett:	218kg
Weight Gross:	261kg

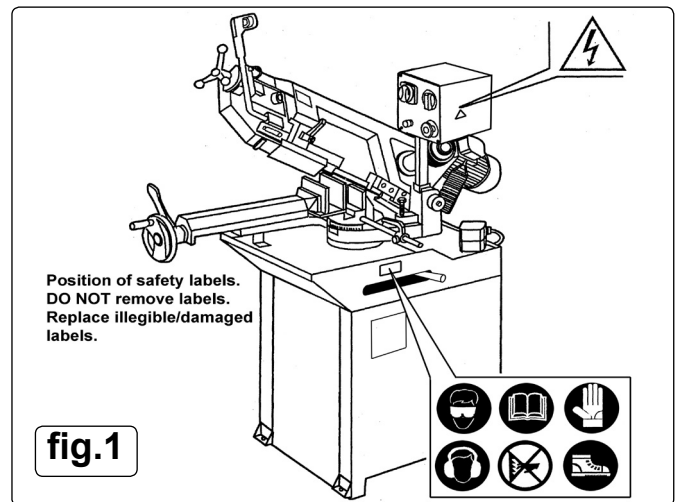

4. HANDLING AND INSTALLATION

4.1. TRANSIT AND LIFTING

- 4.1.1. A fork lift truck will be required to unload the palletised bandsaw and transport it to the installation area.
- 4.1.2. A suitably rated crane used together with chains and shackles should be used to lift the machine onto the sheet metal stand and also to lift the whole assembly into its intended position. See lifting points B & C in Fig.2 above. Alternatively, slings can be used under the vice either side of the central pivot. Great care should be taken to keep the load level and to ensure that the slings **DO NOT** apply pressure to components that should not be heavily stressed.

4.2. INSTALLATION AREA

- 4.2.1. Ensure that there is adequate free space around the machine bearing in mind that it may be necessary to cut from long lengths of steel stock that need to be fed over the roller attached to the back of the machine and that the stock will need to be supported along its length beyond the machine.
- 4.2.2. The surface on which the machine is to be mounted should be flat and level and capable of supporting the weight of the machine and the workpieces.
- 4.2.3. Ensure that the work area is adequately illuminated.
- 4.2.4. The machine should be located near a power supply point that is equipped with an overload cut out and suitable earthing.
- 4.2.5. The installation area should be free from excessive humidity and atmospheric agents that could ignite.

4.3. ASSEMBLY

- 4.3.1. Remove the outer packaging and dispose of it responsibly in accordance with local authority regulations.

4.3.2. SHEETMETAL BASE

- 4.3.2.1. Identify the front panel which has a small access plate bolted to it near the top edge. This front panel has a returned flange along either vertical edge. Bolt an end panel to each vertical flange using the Ø8mm bolts, nuts and washers supplied as shown below. Complete the structure by bolting the back panel into place as shown below in Fig.3.
- 4.3.2.2. Using a suitable crane, lower the machine bed onto the top of the assembled stand. The stand assembly has two large threaded

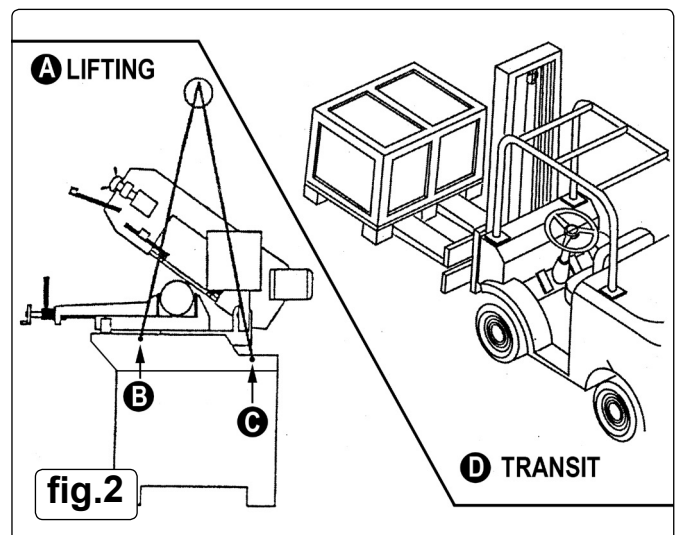

inserts on either side (see Fig.3) and these should be aligned with the fixing holes on either side of the lower edge of the machine bed.

- 4.3.2.3. Bolt the machine bed to the stand using the 10mm bolts and
- 4.3.2.4. Lift the machine and place it in it's intended position. Mark the points. See fig.4.26 and fig.4.27 above.
- 4.3.2.5. Lift the machine to one side and drill the floor to take suitable anchor bolts. Lift the machine back into position and secure it with the chosen fixings. Note: Floor fixings are not provided.

4.3.3. STOP ROD AND BRACKET

- 4.3.3.1. Screw the stop rod into the front of the vice as shown in fig.4.17. Slide the main bracket (16) onto the stop rod with its flat surface facing towards the vice. Bolt the adjustable extension piece into the keyway on the main bracket so that it is facing towards the vice.

4.3.4. CLEANING OFF PROTECTIVE COATINGS

- 4.3.4.1. Clean protective oils from the painted and unpainted surfaces of the machine using a suitable detergent and a dampened cloth. Thoroughly dry the surfaces afterwards.

4.3.5. MAKING THE ELECTRICAL CONNECTION

- 4.3.5.1. Connect the machine to the mains power supply as described in Section 1.

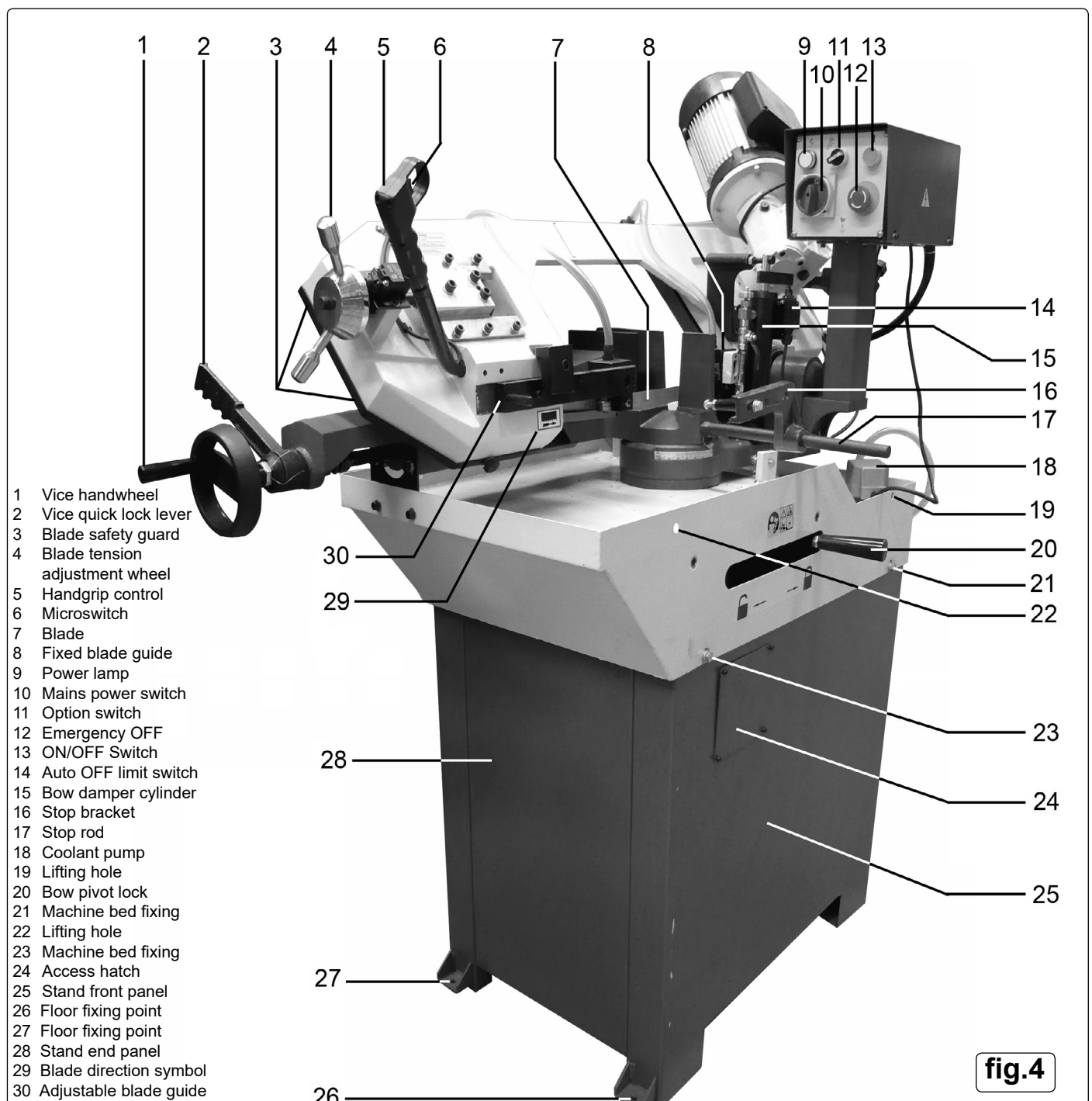
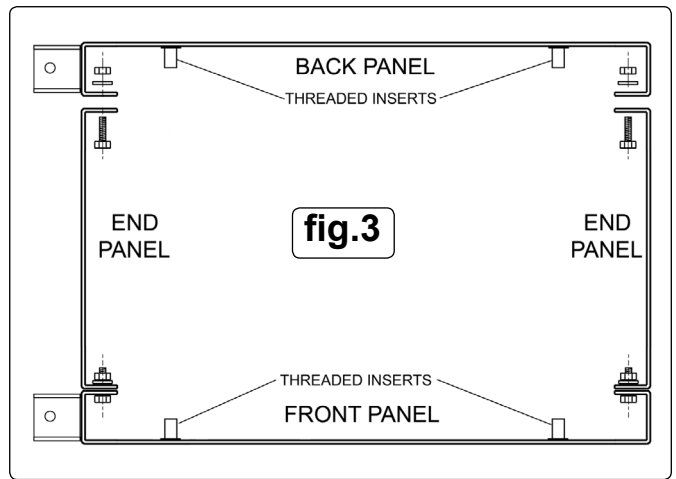

- 1 Vice handwheel
- 2 Vice quick lock lever
- 3 Blade safety guard
- 4 Blade tension adjustment wheel
- 5 Handgrip control
- 6 Microswitch
- 7 Blade
- 8 Fixed blade guide
- 9 Power lamp
- 10 Mains power switch
- 11 Option switch
- 12 Emergency OFF
- 13 ON/OFF Switch
- 14 Auto OFF limit switch
- 15 Bow damper cylinder
- 16 Stop bracket
- 17 Stop rod
- 18 Coolant pump
- 19 Lifting hole
- 20 Bow pivot lock
- 21 Machine bed fixing
- 22 Lifting hole
- 23 Machine bed fixing
- 24 Access hatch
- 25 Stand front panel
- 26 Floor fixing point
- 27 Floor fixing point
- 28 Stand end panel
- 29 Blade direction symbol
- 30 Adjustable blade guide

fig.4

5. SETUP AND ADJUSTMENT

5.1. COOLANT

- 5.1.1. The use of a water soluble coolant will increase cutting efficiency and prolong blade life. Five litres of soluble cutting oil can be ordered under Sealey Part No. SCO5L (follow instructions on pack regarding use and precautions).
- 5.1.2. Coolant is drawn from the coolant tank by the coolant pump (see Fig.4 - 18) and fed through a clear plastic tube to a valve situated on the top edge of the bow casting (see 'J' in Fig.9). When the valve is opened the coolant is fed down two separate pipes which deliver the coolant directly into each blade guide. The coolant is then deposited onto the machine bed where it flows to the lower level and returns to the coolant tank through the grill situated above it for recirculation.
- 5.1.3. The coolant tank can be first filled by pouring the liquid directly through the grill. When the coolant becomes dirty and particle laden it can be drained from the tank through a drain plug situated at the bottom edge of the machine bed on the right hand side. Remember to replace the drain plug before filling with fresh coolant.

5.2. HYDRAULIC BOW DAMPER

- 5.2.1. The rate of descent of the main cutting arm (bow) is controlled by the cylinder (4) shown in Fig.5 below.
- 5.2.2. By turning the knob (1) clockwise the rate of descent is slowed down. By turning the knob anticlockwise the rate of descent is increased. The bow can be locked in any position by turning the hydraulic flow off using the tap (5). When the tap is at 90° to the cylinder the flow is off and the bow will stop moving.
- 5.2.3. Automatic electric shut off When the bow reaches its lowest point the actuation arm (2) operates the microswitch (3) and the power is shut off bringing the blade to a halt.

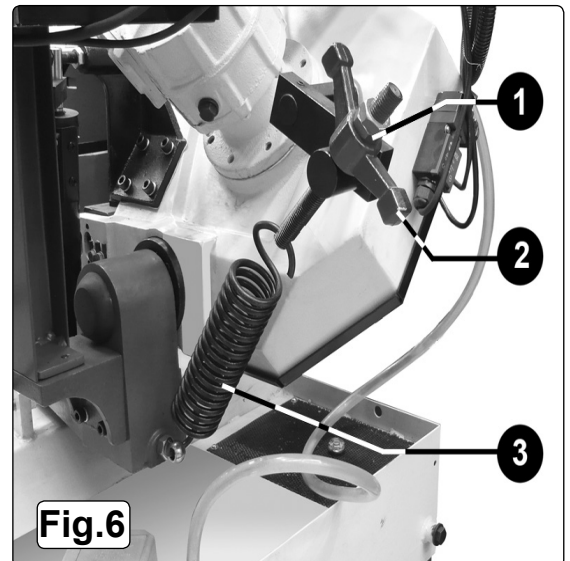
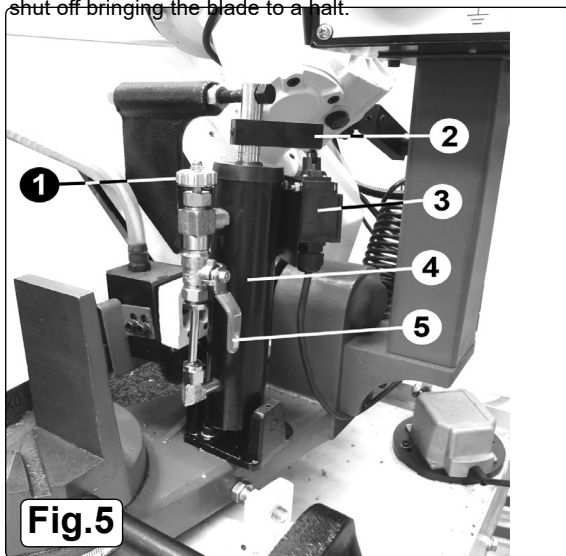

5.3. ADJUSTING BOW WEIGHT (See fig.6)

- 5.3.1. Bow weight is one of the most important adjustments on the saw. Incorrect bow weight can result in poor performance including rough or crooked cuts and premature dulling of the blade. The hydraulic feed rate unit will not compensate for improper bow weight. Bow weight is factory set and should not normally require adjustment.
- 5.3.2. If performance problems are encountered adjust the bow as follows:
- 5.3.2.1. Turn the hydraulic cylinder valve on and place the the saw arm in the horizontal position.
- 5.3.2.2. Turn the feed rate valve at the top of the cylinder anticlockwise until it stops.
- 5.3.2.3. Adjust the spring tensioner in Fig.6 to the required setting for the stock being cut. Turn handle '2' clockwise to slow down the rate of descent.

5.4. VICE SET-UP AND ADJUSTMENT (See fig.7)

- 5.4.1. Adjust the vice opening to be larger than the material to be cut using the hand wheel at the left hand side of the vice assembly. Turn the handwheel clockwise to close the vice. Turn the hand wheel anticlockwise to open the vice.
- 5.4.2. Adjust the position of the stop bracket on the stop rod so that the distance from the flat face of the bracket to the blade is the same as the length of material to be cut as shown below in 'A'.
- 5.4.3. Lift the bow so that the blade is not passing through the vice and lock the position with the tap on the hydraulic unit. Place the metal stock to be cut into the vice so that it is up against the stop bracket as shown below in 'B'. Close the vice to within 2mm of the material. Finally clamp the material in place by sharply moving the clamp lever downwards (anticlockwise).
- 5.4.4. The stop bracket can also be used with the adjustable extension piece shown in Fig.8. The bolt in the end of the extension can be used to

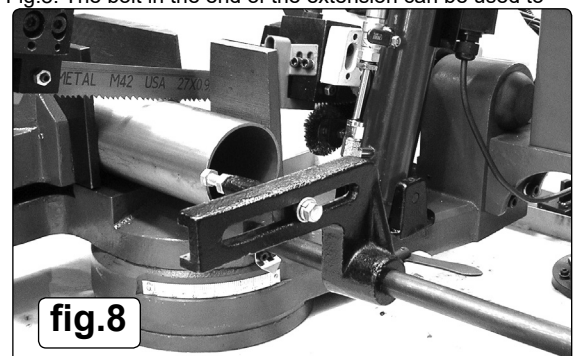
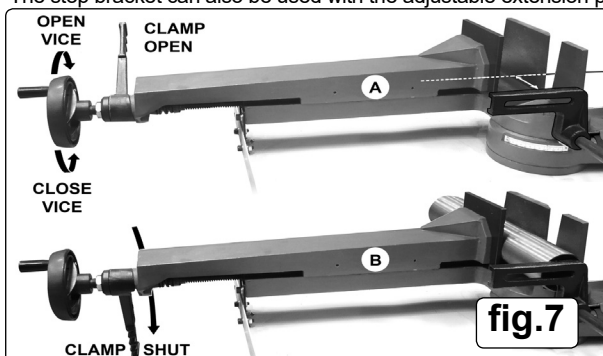

5.5. CUTTING AT AN ANGLE (See Fig.9)

- 5.5.1. In order to cut at an angle, the vice remains where it is and the whole bow assembly pivots round on the machine bed. Line 'D---D' as shown in Fig.9 above represents the line of the blade before the bow is rotated.
- 5.5.2. Loosen the stop bracket and rotate it out of the path of the rotating bow as shown in figure 9 before the bow can be rotated it must be unlocked by moving the lever on the front face of the machine bed to position 'A'. The bow will now pivot around line 'C' and can be set at any angle between 0 and 45° using the scale mounted around the main pivot seen at 'H' above in Fig.9. Additionally the machine will cut at 60° but the blade must be lifted over an area of solid metal and lowered back into the 60° groove. The area of metal between 45° and 60° is necessary to give adequate support to the workpiece either side of the blade especially on round sections.
- 5.5.3. Lock the bow at the chosen angle by moving the locking lever back to position 'B'.
- 5.5.4. Lift the bow upwards from the vice and lock its position with the tap on the hydraulic unit.
- 5.5.5. Reset the position of the stop bracket and clamp the material to be cut in the vice.
- 5.6. **ADJUSTING THE BOW PIVOT TRAVEL LIMITS (See Fig.10)**
- 5.6.1. Unlock the main pivot by moving the lever seen in Fig.9 to position 'A'.
- 5.6.2. The front stop seen in Fig.10 should be used to check that the blade is at 90° to the vice. Place a small set square between the blade and the fixed face of the vice. Loosen the hex nut '1' and wind the bolt '2' in or out until 90° is achieved. Tighten the hex nut '1'. Lock the main pivot by moving the lever to position 'B'.
- 5.6.3. The back stop seen in Fig.10 limits the rotation of the bow to 60°. This is factory set and would not normally need adjusting. **DO NOT** allow the bow to pivot beyond 60°.

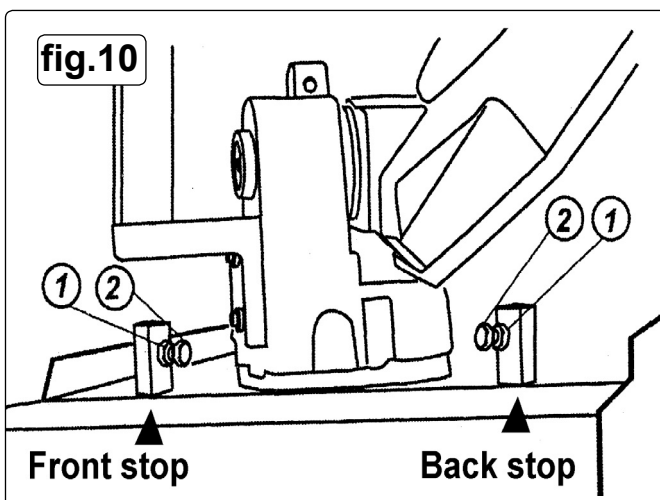
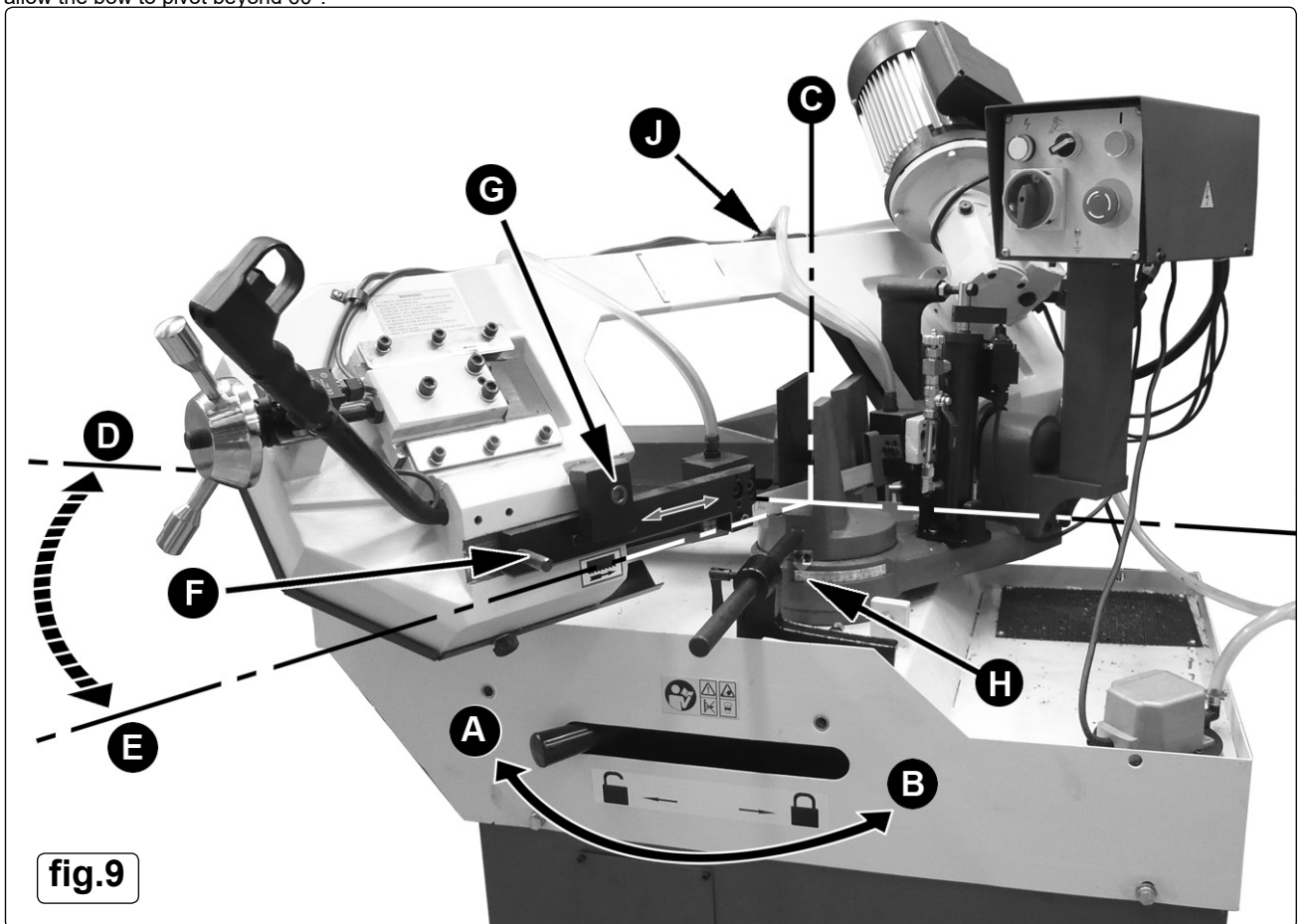

5.7. ADJUSTING THE BOW RETURN STROKE (SEE FIG.11)

- 5.7.1. The lower stop seen in fig.11 is used to control the limit of downward movement of the bow. This is factory set to prevent the blade touching the vice and should not normally require adjustment. The blade cover is shown removed in Fig.11.
- 5.7.2. The upper stop seen in fig.11 is used to control the upper limit of movement of the bow. This is factory set and would not normally need adjusting.

5.8. ADJUSTING THE BLADE GUIDE (See Fig.9)

- 5.8.1. The blade guide nearest to the motor is fixed and cannot be adjusted.
- 5.8.2. In order to adjust the other blade guide first loosen the socket cap bolt 'G' seen above using a 10mm hex. key. Once the clamp block is loose, the blade guide can be moved in or out with the rod 'F'. The blade guide should be set as close as possible to the piece being cut without interfering with it or the vice.
- 5.8.3. Retighten the socket cap bolt.

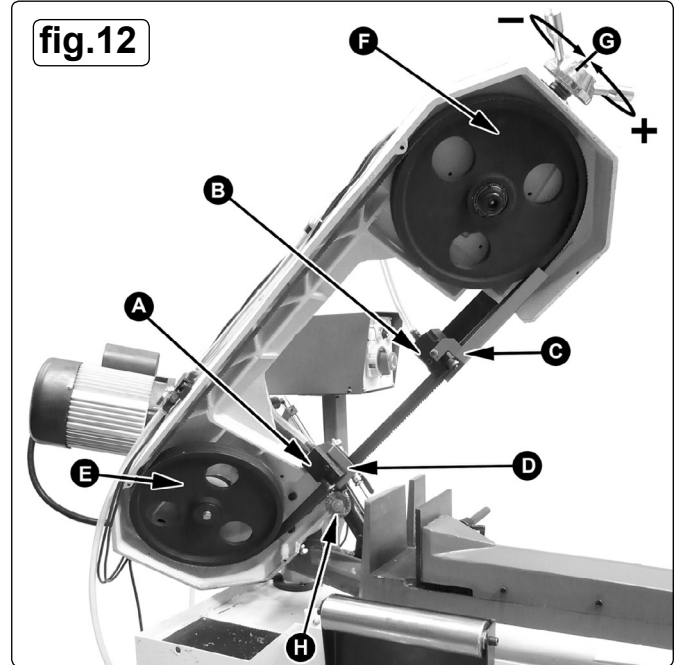
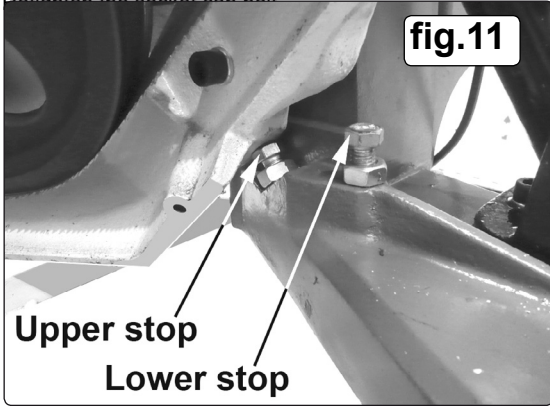

❑ **WARNING!** Turn off the machine and disconnect it from the mains power supply before removing the safety cover from the rear of the bow casting. Wear safety gloves when handling saw blades as the teeth are very sharp.

5.9. CHANGING THE BLADE (See Fig.12)

This saw is designed to work with the following size of blade only, 2460 x 27 x 0.9mm. Fitting any other size may result in serious injury and will invalidate your warranty. The following blades are available from your local Sealey dealer:

Part Number	Size	Teeth per inch
SM355B14	2450 x 27 x 0.9mm	14TPI

- 5.9.1. The black protective cover on the back of the bow casting is held in place by four thumb screws with the addition of a flat actuator blade that passes into a safety switch mounted on the end of the casting below the motor (See Fig.13).
- 5.9.2. Loosen and remove the four thumb screws. Continue to hold the cover in place and take hold of the bottom edge adjacent to the safety switch. Ease the cover away from the casting until the the flat actuator blade withdraws from the safety switch. The cover can now be removed and put to one side.
- 5.9.3. Before the saw blade can be changed the blade safety guards must be removed from the blade guides. See 'C' & 'D' in Fig.12. Use a 5mm hex key to remove the socket cap bolts that hold the blade guards in place.
- 5.9.4. Release the tension on the blade by turning the blade tension wheel 'G' anticlockwise until the blade is loose enough to be removed from the flywheels. See 'E' & 'F' in Fig.12.
- 5.9.5. Ease the blade out of the blade guides. See 'A' & 'B' in Fig.12.
- 5.9.6. When fitting the new blade ensure that it is the correct way round so that the teeth are cutting left to right as you face the machine. See blade tooth label on the front lower part of the bow casting. See 29 in Fig.4 .
- 5.9.7. Feed the new blade into the blade guides first, then ease it onto the flywheels. The blade should be close to, but not hard up against the rim on each flywheel.
- 5.9.8. Refix the blade guards to the appropriate blade guides.
- 5.9.9. Retension the blade by turning the blade tension wheel clockwise until the back of the wheel makes contact with and operates the microswitch adjacent to it. See Fig.14.
- 5.9.10. Refit the protective cover onto the back of the bow casting and retain it with the four thumb screws previously removed. Ensure that the flat actuator blade at the lower end of the cover has entered the microswitch housing as shown in Fig.13.

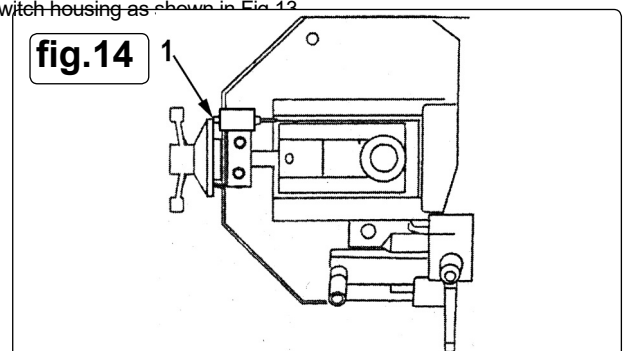
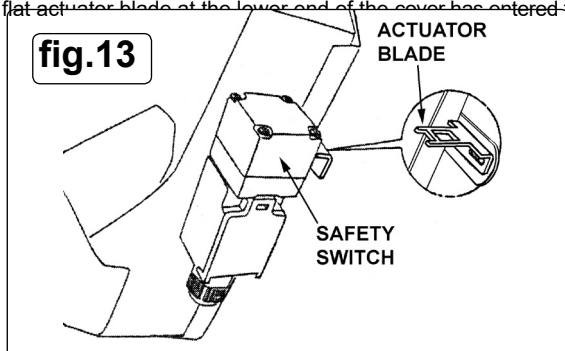

- 5.9.11. Move the bow down to its lowest position. Reconnect the bandsaw to the mains power supply. Switch the machine on and run it for a short while to allow the blade to bed in.
- 5.9.12. If the machine fails to run, disconnect the bandsaw from the mains power supply and investigate the two safety switches. Firstly check that the actuator on the cover has correctly entered the safety switch. Alternatively the blade tension wheel may be touching the microswitch behind the wheel flange but has not fully operated the switch. See Fig.14. Turn the blade tension wheel a further half turn clockwise. Reconnect to the mains power supply and switch on to test.

5.10. BLADE TRACKING ADJUSTMENT

- 5.10.1. The blade tracking is factory set and should not normally require adjustment. If adjustment is thought necessary contact your Sealey stockist.

5.11. BLADE GUIDE BEARING ADJUSTMENT

- 5.11.1. The blade guide bearings are factory set and should not normally require adjustment. If adjustment is thought necessary contact your Sealey stockist.

6. OPERATION

- ❑ **WARNING!** Before operating the bandsaw read the entire manual to familiarise yourself with all aspects of the machine. Pay particular attention to the Safety instructions in Section 1.
 - NOTE:** Before operating the machine certain checks and adjustments will need to be carried out as detailed in Section 5 'Set Up and Adjustments'. It is very important that these instructions are followed carefully in order that the machine is set up safely and correctly.
 - ❑ **WARNING!** The machine is designed for metal cutting work in engineering workshops, garages, metal fabricators, etc. The SM355CE must not be used to cut any other materials (including wood). To do so will invalidate your insurance cover and your warranty and may cause damage and/or personal injury.
 - ❑ **WARNING!** Never operate the saw unless all blade guards are installed and working properly.
- 6.1. Ensure that the saw is disconnected from the power supply.
- 6.2. Adjust the stop bracket to the desired length on the stop rod as described in Section 5.4.
- 6.3. Adjust the vice to the desired angle or set up at 90° to the blade as required and as described in Sections 5.4 and 5.5. Open vice, insert the workpiece and clamp it securely.
- 6.4. Adjust the blade guide so that it is close to the workpiece as described in Section 5.8.
- 6.5. Adjust the rate of descent of the arm as described in Section 5.2 so that it is creeping slowly down towards the workpiece. Shut off the hydraulic cylinder when the blade gets close to the workpiece. **DO NOT** start cutting on a sharp edge. File it off first. **DO NOT** turn on machine until workpiece is secured and blade has been lowered to just above workpiece.
- 6.6. Before starting the machine ensure that the bed cannot rotate by moving the lever on the front face of the machine bed to the locked position i.e. fully over to the right. (See 20 in fig.4).
- 6.7. Turn on the mains power by turning the switch clockwise. See (1) in Fig.15. The power lamp (2) will light.
- 6.8. Using switch (3) select whether the machine will turn on with the Start Button (4) on the control panel or the handgrip switch. See (6) in Fig.4.
- 6.9. Control panel start. Start the saw by pressing the start button on the control panel.
- 6.10. Having previously set the rate of descent allow the blade to descend slowly onto the workpiece by turning the hydraulic tap to be in line with the cylinder. (If the blade should jam or other problems occur immediately switch off the power by hitting the red emergency OFF button. Refer to the 'Troubleshooting' section for common problems).
- 6.11. The coolant pump starts automatically when the machine is turned on and feeds coolant directly to the blade guides. The flow can be regulated using the coolant feed tap as described in section 5.1.
- 6.12. When the cut is completed the machine will switch off automatically. Turn the mains power switch off and disconnect the saw from the power supply, raise the blade and remove the workpiece. Wear gloves as the workpiece will be hot and have sharp edges.
- 6.13. Hand grip start. The handgrip is used in conjunction with the hydraulic damper to provide an extra degree of control, especially when the blade first comes into contact with the workpiece. Furthermore the hand grip switch has to be held down to keep the blade running so the machine can be stopped quickly by releasing the switch if problems occur such as the blade jamming.
- 6.14. In order to start the machine with the hand grip switch (See 5 in Fig.4) the selection switch on the control panel (See 3 in Fig.15) must be turned to the hand grip symbol.
- 6.15. Set the blade rotating by holding down the handgrip switch. Having previously set the rate of descent allow the blade to move slowly down towards the workpiece by turning the hydraulic tap to be in line with the cylinder. Allow the blade to rest lightly onto the workpiece whilst making the initial cut. Keep the switch held down whilst the cut progresses. (If the blade should jam or other problems occur release the hand grip switch immediately).
- 6.16. The coolant pump starts automatically when the machine is turned on and feeds coolant directly to the blade guides. The flow can be regulated using the coolant feed tap as described in section 5.1.
- 6.17. When the cut is completed the machine will switch off automatically. Turn the mains power switch off and disconnect the saw from the power supply, raise the blade and remove the workpiece.
- ❑ **WARNING!** Never raise blade when machine is running.
 - ❑ **WARNING!** Wear gloves when handling sawn metal parts as the cutting process will produce sharp edges.
 - ❑ **WARNING!** **DO NOT** rotate the bow when the machine is running.

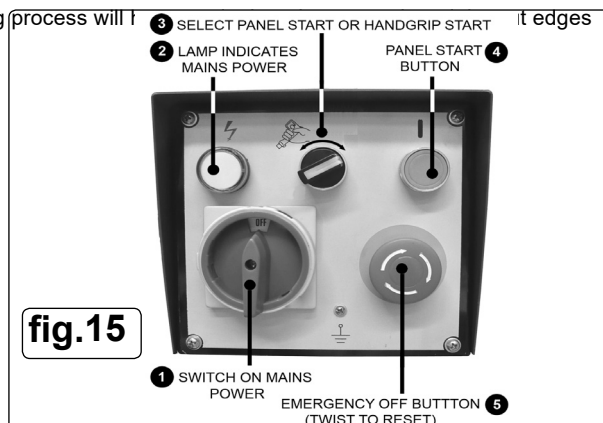

fig.15

- 6.17.1. Move the bow down to its lowest position. Reconnect the bandsaw to the mains power supply. Switch the machine on and run it for a short while to allow the blade to bed in.
- 6.17.2. If the machine fails to run, disconnect the bandsaw from the mains power supply and investigate the two safety switches. Firstly check that the actuator on the cover has correctly entered the safety switch. Alternatively the blade tension wheel may be touching the microswitch behind the wheel flange but has not fully operated the switch. See Fig.14. Turn the blade tension wheel a further half turn clockwise. Reconnect to the mains power supply and switch on to test.

6.18. **BLADE TRACKING ADJUSTMENT**

- 6.18.1. The blade tracking is factory set and should not normally require adjustment. If adjustment is thought necessary contact your Sealey stockist.

6.19. **BLADE GUIDE BEARING ADJUSTMENT**

- 6.19.1. The blade guide bearings are factory set and should not normally require adjustment. If adjustment is thought necessary contact your Sealey stockist.

7. MAINTENANCE

- WARNING!** Disconnect the bandsaw from the power source before servicing, changing accessories, or performing any other maintenance.
- 7.1. Check the gearbox oil level on a monthly basis. This should be done with the bow raised to its highest position. Observe the oil level in the sight glass on the side of the gearbox. If required, top up the oil by removing the filler bolt from the upper part of the gearbox just below the motor. Change the oil every 6 months. The drain plug is at the bottom of the gearbox. Drain the gearbox with the bow in its highest position.
- 7.2. Keep all surfaces clean and free from rust, slag, chips and coolant build-up.
DO NOT use compressed air to clean bandsaw. Compressed air may force chips into the guide bearings and other critical areas of the saw.
- 7.3. Use a small paint brush or parts cleaning brush to remove metal particles.
- 7.4. Wipe saw down with a clean dry cloth and oil all unpainted surfaces with light machine oil.
- 7.5. Keep blade guides clean and free from metal chips.
- 7.6. Check guide bearings frequently to make sure they are properly adjusted and running freely.
- 7.7. **BLADE CLEANING BRUSH.** It is important that the blade cleaning brush be properly adjusted and kept in good working order. The brush is mounted behind the fixed blade guide. (See 'H' in Fig.12) Blade life will be shortened severely if the brush is allowed to go out of adjustment, becomes worn or damaged. Replace the brush if it becomes worn or damaged.
- 7.8. Clean out the coolant tank at least twice a year.
- WARNING! DO NOT** attempt to adjust the blade brush with the machine running. Adjust only when the machine is disconnected from the power source.

8. TROUBLESHOOTING

PROBLEM	CAUSE	SOLUTION
Excessive blade breakage and/or teeth ripping from the blade.	1. Workpiece is loose in the vice.	1. Clamp the workpiece securely.
	2. Incorrect feed.	2. Check bow weight and hydraulic feed.
	3. Blade is too coarse.	3. See Section 4.9 for available blade types.
	4. Workpiece material is too coarse.	4. Use the saw with a smaller tpi blade.
	5. Incorrect blade tension.	5. Adjust blade tension so that it does not slip on the wheel.
	6. Blade is in contact with workpiece before saw is started.	6. Place blade in contact with the workpiece only after the saw has started.
	7. Blade is rubbing on the wheel flange.	7. If blade tracking needs adjustment, contact your local Sealey dealer.
	8. Blade guides are misaligned.	8. If blade guides need adjustment, contact your local Sealey dealer.
	9. Blade is too thick.	9. Use correct thickness blade.
	10. Bad weld on blade.	10. Replace blade.
Premature blade dulling.	1. Blade tpi is too high.	1. Replace with a smaller tpi blade.
	2. Inadequate feed pressure.	2. Increase feed pressure by decreasing bow weight.
	3. Hard spots or scale on the workpiece.	3. Increase feed pressure by decreasing bow weight.
	4. Blade installed backwards.	4. Remove blade, twist inside out and reinstall.
	5. Insufficient blade tension.	5. Increase blade tension.
	6. Work hardened material especially stainless.	6. Increase feed pressure by decreasing bow weight.
Unusual wear on side or back of blade.	1. Blade guides are worn.	1. Replace blade guides.
	2. Blade guides not properly adjusted.	2. Adjust as described in manual.
	3. Blade guide brackets are loose.	3. Tighten blade guide brackets.
Motor overheating.	1. Blade tension too high.	1. Reduce blade tension.
	3. Blade too coarse or too fine.	3. Use a blade more suitable for the material being cut.
	4. Gears need lubrication.	4. Top up gearbox.
	5. Blade is binding in the cut.	5. Decrease feed.
Bad, crooked or rough cuts.	1. Feed pressure too great.	1. Reduce feed pressure by increasing bow weight.
	2. Blade guide bearings not properly adjusted.	2. Contact your Sealey dealer.
	3. Inadequate blade tension.	3. Increase blade tension a little at a time.
	4. Blade is dull.	4. Replace the blade.
	6. Blade guide too far away from workpiece.	6. Move guide closer to workpiece.
	7. Blade guide assembly is loose.	7. Tighten the guide assembly.
	8. Blade is too coarse.	8. Use a finer blade.

Blade is twisting.	1. Blade is binding in the cut.	1. Decrease feed pressure.
	2. Blade tension is too high.	2. Decrease blade tension.



ENVIRONMENT PROTECTION

Recycle unwanted materials instead of disposing of them as waste. All tools, accessories and packaging should be sorted, taken to a recycling centre and disposed of in a manner which is compatible with the environment. When the product becomes completely unserviceable and requires disposal, drain any fluids (if applicable) into approved containers and dispose of the product and fluids according to local regulations.



WEEE REGULATIONS

Dispose of this product at the end of its working life in compliance with the EU Directive on Waste Electrical and Electronic Equipment (WEEE). When the product is no longer required, it must be disposed of in an environmentally protective way. Contact your local solid waste authority for recycling information.

Note: It is our policy to continually improve products and as such we reserve the right to alter data, specifications and component parts without prior notice.

Important: No Liability is accepted for incorrect use of this product.

Warranty: Guarantee is 12 months from purchase date, proof of which is required for any claim.

Sealey Group, Kempson Way, Suffolk Business Park, Bury St Edmunds, Suffolk. IP32 7AR



01284 757500



01284 703534



sales@sealey.co.uk



www.sealey.co.uk