



DISC SANDER Ø305mm

MODEL NO: **SM31.V4**

Thank you for purchasing a Sealey product. Manufactured to a high standard, this product will, if used according to these instructions, and properly maintained, give you years of trouble free performance.

IMPORTANT: PLEASE READ THESE INSTRUCTIONS CAREFULLY. NOTE THE SAFE OPERATIONAL REQUIREMENTS, WARNINGS & CAUTIONS. USE THE PRODUCT CORRECTLY AND WITH CARE FOR THE PURPOSE FOR WHICH IT IS INTENDED. FAILURE TO DO SO MAY CAUSE DAMAGE AND/OR PERSONAL INJURY AND WILL INVALIDATE THE WARRANTY. KEEP THESE INSTRUCTIONS SAFE FOR FUTURE USE.



Refer to instructions



Wear eye protection



Wear protective gloves



Wear ear protection



Wear a mask



Indoor use only

1. SAFETY

1.1. ELECTRICAL SAFETY

- WARNING!** It is the user's responsibility to check the following:
- ✓ Check all electrical equipment and appliances to ensure that they are safe before using. Inspect power supply leads, plugs and all electrical connections for wear and damage. Sealey recommend that an RCD (Residual Current Device) is used with all electrical products.
- ✓ Electrical safety information. It is important that the following information is read and understood:
- ✓ Ensure that the insulation on all cables and on the appliance is safe before connecting it to the power supply.
- ✓ Regularly inspect power supply cables and plugs for wear or damage and check all connections to ensure that they are secure.
Important: Ensure that the voltage rating on the appliance suits the power supply to be used and that the plug is fitted with the correct fuse.
- ✗ **DO NOT** pull or carry the appliance by the power cable.
- ✗ **DO NOT** pull the plug from the socket by the cable. Guard against electric shock.
- ✗ **DO NOT** use worn or damaged cables, plugs or connectors. Ensure that any faulty item is repaired or is replaced immediately by qualified electrician.
- ✓ If the cable or plug is damaged during use, switch off the electricity supply and remove from use.
- ✓ Ensure that repairs are carried out by a qualified electrician.
If the cable or plug is damaged during use, switch off the electricity supply and remove from use.
- ✓ Replacement of the plug or the supply cord shall always be carried out by the manufacturer of the tool or their service organisation.
- ✓ Keep water clear of the electrical parts of the tool and away from persons in the working area.

Ensure that repairs are carried out by a qualified electrician.

GENERAL SAFETY

1.2. GENERAL POWER TOOL SAFETY WARNINGS

- WARNING!** Read all safety warnings and all instructions. This power tool is intended to function as a sander. Operations such as grinding, wire brushing, polishing or cutting off are not recommended to be performed with this power tool. Failure to follow the warnings and instructions may result in electric shock, fire and/or serious injury.
- WARNING!** Ensure that Health & Safety, local authority and general workshop practice regulations are adhered to when using this sander.
- ✓ Save all warnings and instructions for future reference.

1.3. WORK AREA SAFETY

- ✓ Keep work area clean and well lit. Cluttered or dark areas invite accidents.
- ✓ Consider your work area environment:
- ✗ **DO NOT** expose tools to rain.
- ✗ **DO NOT** use tools in damp or wet locations.
- ✗ **DO NOT** operate power tools in explosive atmospheres, such as in the presence of flammable liquids, gases or dust. Power tools create sparks which may ignite the dust or fumes.
- ✓ Keep children and bystanders away while operating a power tool. Distractions can cause you to lose control.

1.4. PERSONAL SAFETY

- ✓ Stay alert, watch what you are doing and use common sense when operating a power tool. **DO NOT** use a power tool while you are tired or under the influence of drugs, alcohol or medication. A moment of inattention while operating power tools may result in serious personal injury.
- ✓ Wear personal protective equipment. Depending on application, use safety goggles or safety glasses.
As appropriate, wear dust mask, hearing protectors, gloves and workshop apron capable of stopping small abrasive or workpiece fragments.
- ✓ Prevent unintentional starting. Ensure the switch is in the off-position before connecting to power source and/or battery pack, picking up or carrying the tool.
- ✗ **DO NOT** overreach. Keep proper footing and balance at all times. This enables better control of the power tool in unexpected situations.
- ✓ Dress properly. **DO NOT** wear loose clothing or jewellery. Keep your hair, clothing and gloves away from moving parts. Loose clothes, jewellery or long hair can be caught in moving parts.
- ✓ Keep bystanders a safe distance away from work area. Anyone entering the work area must wear personal protective equipment.
- ✓ Position the power cord clear of the spinning accessory.
- ✓ Regularly clean the power tool's air vents.

- ✓ If devices are provided for the connection of dust extraction and collection facilities, ensure these are connected and properly used.
 - ✗ **DO NOT** operate the power tool near flammable materials.
- 1.5. KICKBACK AND RELATED WARNINGS**
- ✓ Never place your hand near a rotating accessory.
 - ✓ Use special care when working corners, sharp edges etc. Avoid bouncing and snagging the accessory.
- 1.6. POWER TOOL USE AND CARE**
- ✗ **DO NOT** force the power tool. Use the correct power tool for your application. The correct power tool will do the job better and safer at the rate for which it was designed.
 - ✗ **DO NOT** use the power tool if the switch does not turn it on and off. Any power tool that cannot be controlled with the switch is dangerous and must be repaired.
 - **WARNING!** Disconnect the plug from the mains supply before making any adjustments, changing accessories, or storage.
 - ✓ Store idle power tools out of the reach of children and do not allow persons unfamiliar with the power tool or these instructions to operate the power tool. Power tools are dangerous in the hands of untrained users.
 - ✓ Maintain power tools. Check for misalignment or binding of moving parts, breakage of parts and any other condition that may affect the power tool's operation. If damaged, have the power tool repaired before use. Many accidents are caused by poorly maintained power tools.
 - ✓ Use the power tool in accordance with these instructions, taking into account the working conditions and the work to be performed. Use of the power tool for operations different from those intended could result in a hazardous situation.
- 1.7. SERVICE**
- ✓ Have your power tool serviced by a qualified repair person using only identical replacement parts. This will ensure that the safety of the power tool is maintained. Unauthorised parts may be dangerous and will invalidate the warranty.
- 1.8. SPECIFIC SANDER SAFETY**
- **WARNING!** Disconnect from mains supply and ensure that the pad is at a complete standstill before changing, servicing or performing any maintenance.
 - **WARNING!** Keep all guards and holding screws in place, tight and in good working order.
 - ✗ **DO NOT** use excessively oversized sanding disc paper. Follow the sanding disc manufacturer's recommendations.
 - ✓ Check regularly for damaged parts. A guard or any other part that is damaged must be repaired/replaced before the sander is next used.
 - ✓ Keep the sander clean for best and safest performance.
 - ✓ Before each use check all attachments for condition. If worn or damaged replace immediately.
 - ✗ **DO NOT** get the sander wet or use in damp or wet locations or areas where there is condensation.
 - ✗ **DO NOT** allow untrained persons to operate the sander.
 - ✓ When not in use, unplug from the mains power supply and store in a safe, dry, childproof area.
- 1.9. LEAD PAINT WARNING!**
- Paint once contained lead as a traditional ingredient. The dust from the removal of such paint is toxic if inhaled or ingested and must, therefore, be avoided. The following action must be taken before using the sander on a surface that you suspect may have contained lead in the paint.
1. User must determine potential hazard relating to age of paint to be removed. (Modern paints do not contain lead).
 2. **DANGER!** Keep all persons and pets away from the work area. The following are particularly vulnerable to the effects of lead paint dust: Expectant women, babies and children.
 3. We recommend personal protection by using the following safety items:
 - a) Paint Spray Respirator (Sealey ref: SSP1699).
 - b) PE Coated Hooded Coverall (Sealey ref: SSP266).
 - c) Latex Gloves (Sealey ref: SSP24).
 4. Take adequate measures to contain the paint dust, flakes, and scrapings.
 5. Continue to wear safety equipment as in 3 above, and thoroughly clean all areas when task is complete. Ensure that paint waste is disposed of, in sealed bags or containers, according to local authority regulations.

2. INTRODUCTION

Bench mounting semi-portable disc sander suitable for general woodworking applications. Powerful induction motor with smooth direct drive. Balanced aluminium sanding disc suitable for adhesive backed discs. Sanding disc table tilts to 45° and is supplied with mitre gauge for accurate angle sanding.

3. SPECIFICATION

Model no:	SM31.V4
Consumable Parts:	SM31/38 - Sanding Disc Ø305mm 80Grit PSA
Disc Size:	Ø305mm
Disc Speed:	1450rpm
Dust Extraction Diameter:	Ø52mm
Fuse Rating:	10A
Motor Power:	750W
Power Supply Cable Length:	2m
Table Size:	156 x 438mm
Table Tilt:	45°

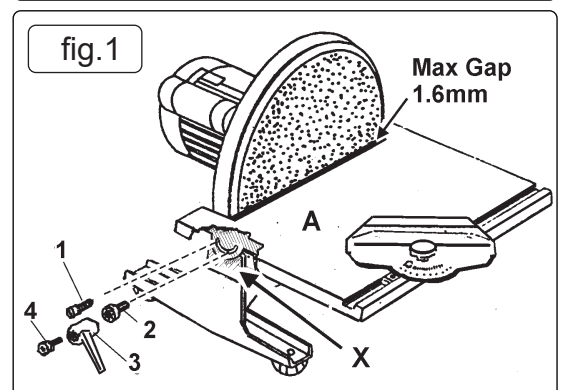
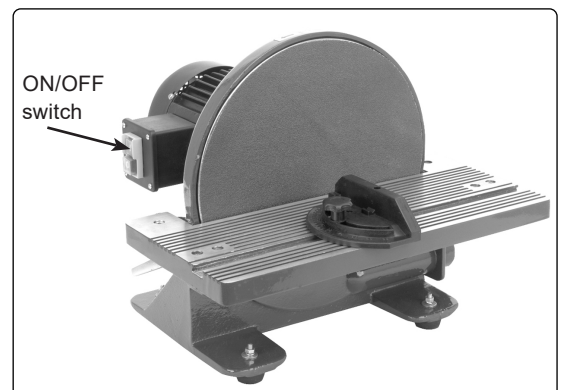

4. ASSEMBLY

- 4.1. Unpack the sander and check contents against the list below. If there are any damaged or missing parts contact your supplier immediately.
- CONTENTS:**
- Sander Assembly
 - Table
 - Mitre Gauge
 - Hex Key
- 4.2. Remove various screws (fig.1 parts1-4) from the sander assembly, fit table (A) in position and retain by replacing screws. The table should always have at least 1.6mm clearance from the sanding disc adjustment can be made by loosening the six cross head bolts in the face of the table top.
- 4.3. If a dust extraction system is available, connect it to the extraction port (diameter 52mm).
- 4.4. The mitre gauge, when required, locates in the table groove. (fig.1).
- WARNING! Before use, the machine must be positioned on a stable, fireproof bench or table which is strong enough to take the weight of the machine and the workpiece. The sander is supplied with rubber feet, alternatively it can be bolted to a work surface. Failure to comply with this instruction could result in severe personal injury.**

5. OPERATION

- 5.1. Ensure that you have read, understand and apply the safety instructions in Section 1.
- WARNING!** Before each use rotate the sanding disc by hand to check it is undamaged and secure. Remove adjusting keys and wrenches before turning the machine on.
- 5.2. TABLE ADJUSTMENT**
- 5.2.1. The table is adjustable through 45° by slackening the two locking lever handles (fig.1.3.) - both right hand thread, adjusting the table to the required angle and then fully tightening both handles.
- 5.3. MITRE GAUGE ADJUSTMENT**
- 5.3.1. The gauge is adjustable through $\pm 45^\circ$ by slackening the thumb screw, adjusting to required angle and tightening the thumb screw.
- 5.4. OPERATING THE SANDER**
- 5.4.1. Feed workpiece carefully into the sanding disc, work methodically and **DO NOT** force the sander to remove material faster than it was designed for. Hold workpiece with both hands and ensure that they are not in a position where they could slip up against the sanding disc.
- 5.4.2. Ensure large workpieces are supported at table height.
- 5.4.3. Turn sander off and make sure sanding disc is stationary before clearing scrap pieces from the table.

6. MAINTENANCE

- 6.1. Remove the plug before carrying out any adjustments, servicing or maintenance .
- 6.2. The sander is maintenance free and only requires cleaning using a vacuum cleaner and brush.
- 6.3. Occasionally check sander over for loose fittings and to ensure sanding disc is secure. Change pads when required.
- 6.4. All other service and maintenance be carried out by an authorised Sealey stockist.
- 6.5. When not in use store in a safe, dry, childproof location.



ENVIRONMENT PROTECTION

Recycle unwanted materials instead of disposing of them as waste. All tools, accessories and packaging should be sorted, taken to a recycling centre and disposed of in a manner which is compatible with the environment. When the product becomes completely unserviceable and requires disposal, drain any fluids (if applicable) into approved containers and dispose of the product and fluids according to local regulations.



REGISTER YOUR PURCHASE HERE

Note: It is our policy to continually improve products and as such we reserve the right to alter data, specifications and component parts without prior notice. Please note that other versions of this product are available. If you require documentation for alternative versions, please email or call our technical team on technical@sealey.co.uk or 01284 757505.

Important: No Liability is accepted for incorrect use of this product.

Warranty: Guarantee is 12 months from purchase date, proof of which is required for any claim.

Sealey Group, Kempson Way, Suffolk Business Park, Bury St Edmunds, Suffolk. IP32 7AR



01284 757500



sales@sealey.co.uk



www.sealey.co.uk