



INSTRUCTIONS FOR:

## DIGITAL FEED DISPLAY FOR SM3002

### MODEL: SM3002DFD

Thank you for purchasing a Sealey product. Manufactured to a high standard this product will, if used according to these instructions and properly maintained, give you years of trouble free performance.



**IMPORTANT: PLEASE READ THESE INSTRUCTIONS CAREFULLY. NOTE THE SAFE OPERATIONAL REQUIREMENTS, WARNINGS & CAUTIONS. USE THE PRODUCT CORRECTLY AND WITH CARE FOR THE PURPOSE FOR WHICH IT IS INTENDED. FAILURE TO DO SO MAY CAUSE DAMAGE AND/OR PERSONAL INJURY AND WILL INVALIDATE THE WARRANTY. PLEASE KEEP INSTRUCTIONS SAFE FOR FUTURE USE.**

## 1. INTRODUCTION

Digital display for the cross slide and the compound tool rest to replace the standard graduated scales. These LCD units improve accuracy, save reading time and minimise errors. Imperial or Metric readings may be selected and the reading can be zeroed at any point. Three decimal place (Metric) and four decimal place (Imperial) displays with an accuracy of  $\pm 0.025\text{mm}/0.001''$ .

## 2. CONTENTS

1. Cross slide feed screw
2. Compound rest feed screw
3. Screws and spacers
4. Cross slide screw retainer
5. Cross slide feed nut
6. Compound rest screw retainer
7. Compound rest bottom
8. Digital displays

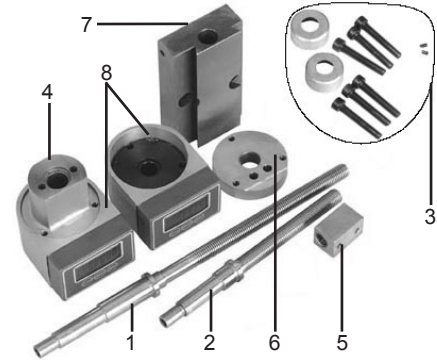

## 3. INSTALLATION 1

Installing the Compound Rest digital display.

fig 1

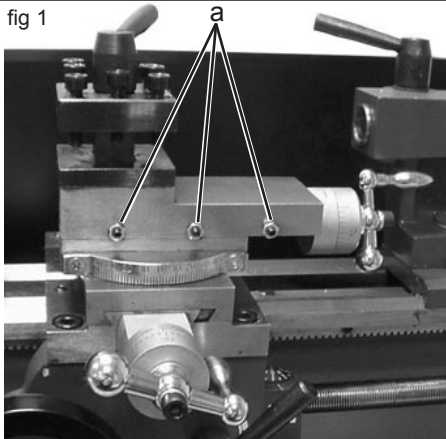

3.1 Loosen the compound rest gibs (fig 1a) and crank the compound rest feed handle anticlockwise to remove the top of the compound rest from the compound rest bottom.

fig 2

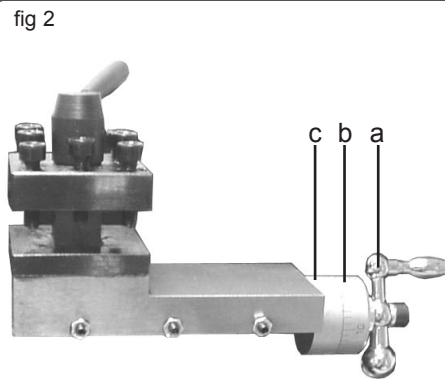

3.2 Undo the handle screw of the graduated scale (fig 2a) and remove the spring clip and scale (fig 2b). Remove the compound rest screw retainer (fig 2c) (retaining the fixing screws for future use) and remove the compound rest feed screw.

fig 3

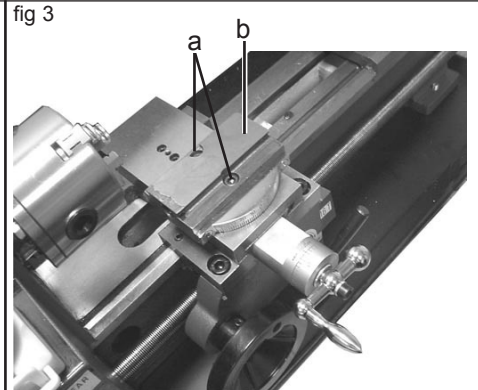

3.3 Remove the two large hex screws (fig 3a) (retaining them for future use). Remove the compound rest bottom (fig 3b) from the cross slide.

fig 4

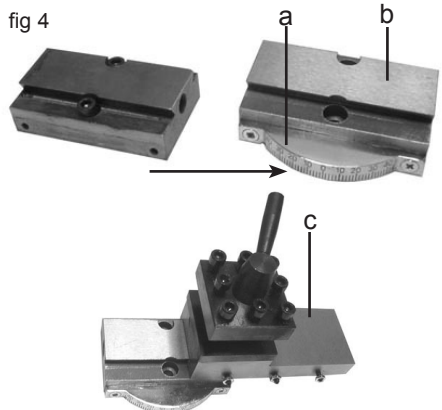

3.4 Move the protractor (fig 4a) to the new compound rest bottom (fig 4b) and slide the compound rest top (fig 4c) a short way onto the new compound rest bottom, being sure to leave the two large screw holes uncovered.

fig 5

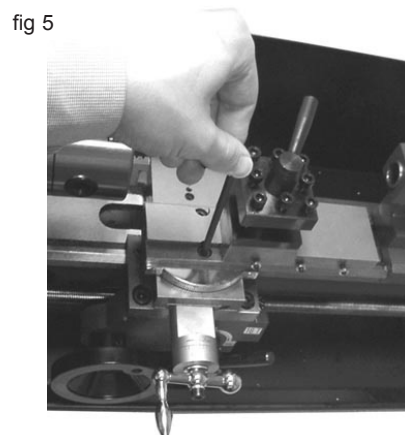

3.5 Screw the compound rest back onto the cross slide using the two large hex screws. Adjust the gib screws so that the compound rest may be moved by hand but with some resistance.

fig 6

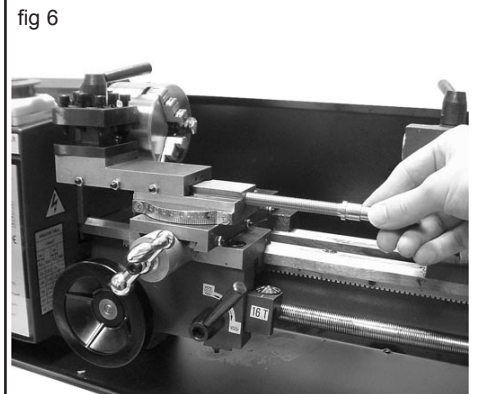

3.6 Screw the new compound rest feed screw into the compound rest bottom.

fig 7

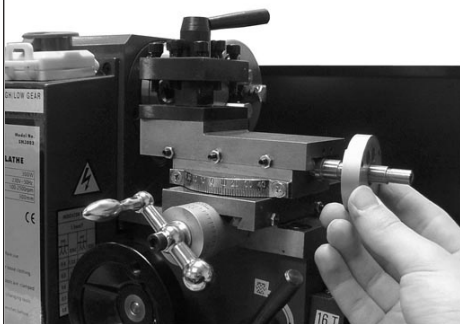

3.7 Install the new compound rest screw retainer using the screws removed from the original.

fig 8

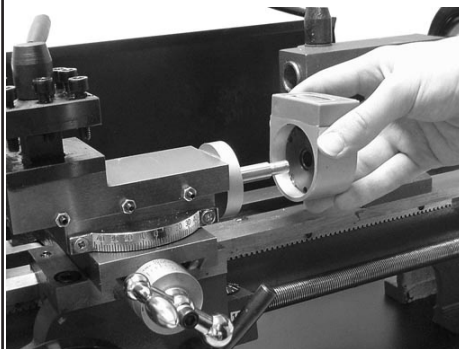

3.8 Install the digital display.

fig 9

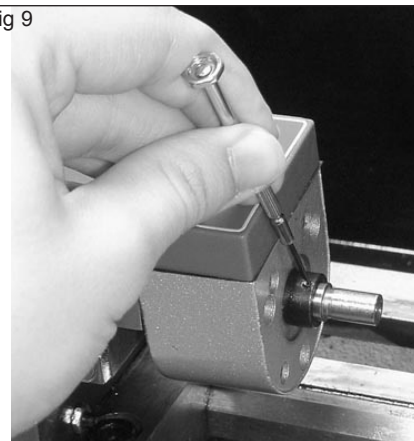

3.9 Install one of the small setscrews provided. Be sure the screw fits tightly and correctly into the slot on the feed screw.

fig 10

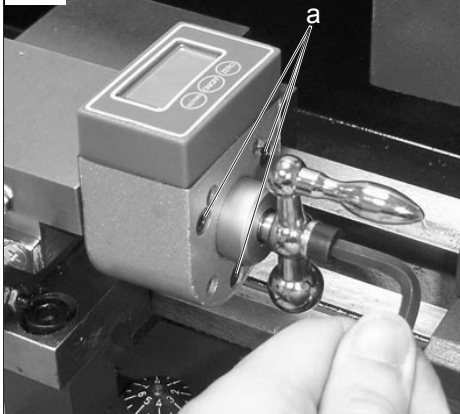

3.10 Install the digital display retaining screws (provided) (fig 10a), then install the spacer washer provided and the compound rest feed handle.

## 4. INSTALLATION 2

Installing the Cross Slide digital display.

fig 11

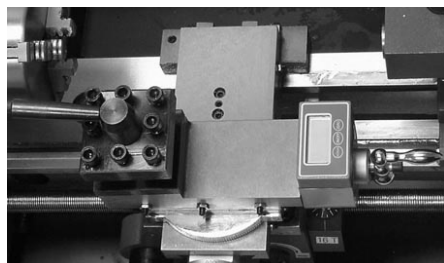

4.1 Remove the two socket head cap screws that retain the cross slide feed nut.

fig 12

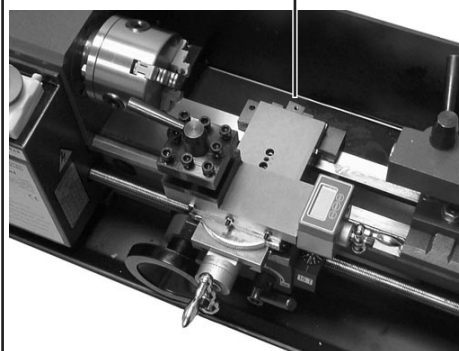

4.2 Remove the cross slide feed nut (fig 12a) by turning the cross slide feed handle clockwise.

fig 13

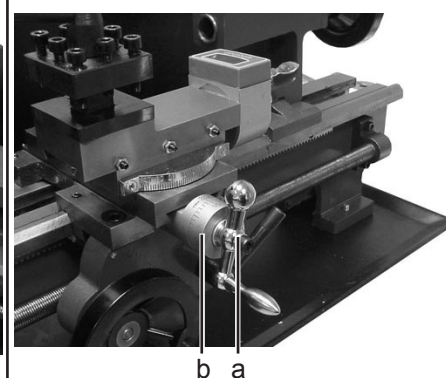

4.3 Remove the cross slide feed handle (fig 13a), the spacer washer and the dial (fig 13b).

fig 14

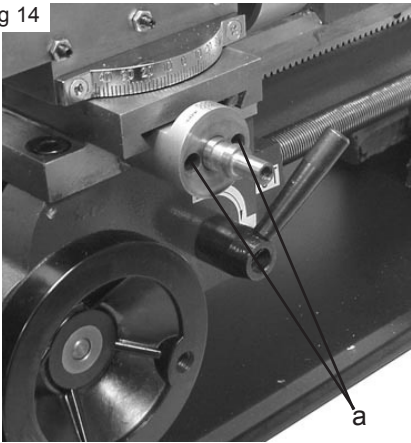

4.4 Remove the two screws (fig 14a) from the cross slide screw retainer. Retain them for future use.

fig 15

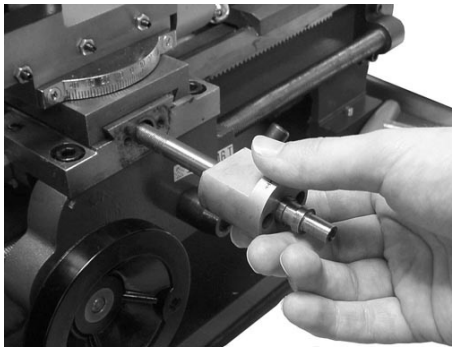

4.5 Remove the cross slide screw retainer together with the cross slide feed screw.

fig 16

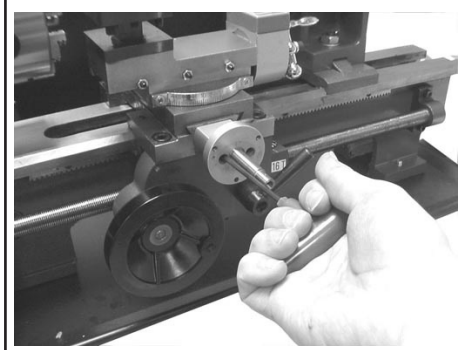

4.6 Install the new cross feed slide screw and retainer. Install the two screws taken from the original retainer.

fig 17

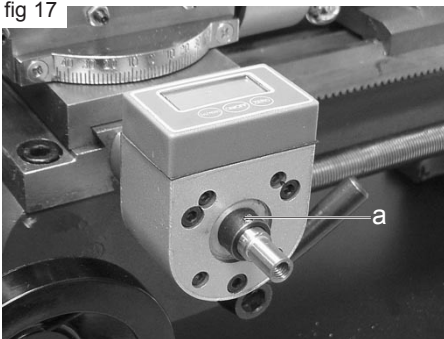

4.7 Install the digital display and one of the small set screws provided (fig 17a). Ensure the set screw fits into the slot in the feed screw. Install the retaining screws provided - do not overtighten.

fig 18

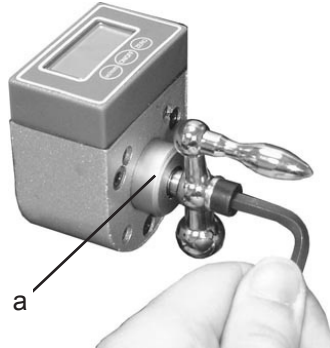

4.8 Install the spacer washer provided (fig 18a) and the cross slide rest feed handle.

fig 19

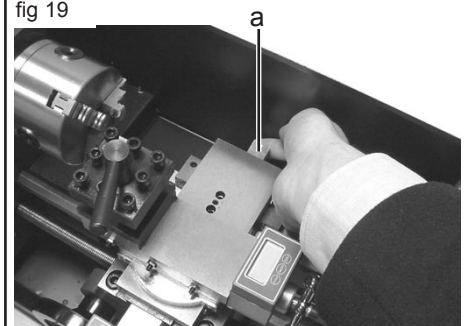

4.9 Fit the new cross slide feed nut (fig 19a) on the cross slide feed screw. The screw holes in the nut must be facing upwards.

fig 20

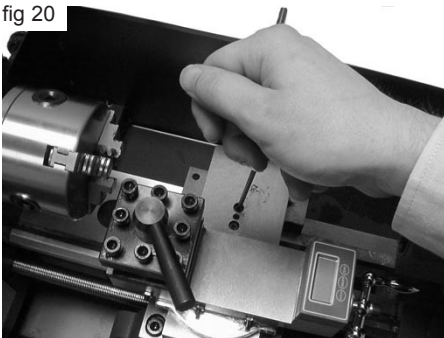

4.10 Rotate the handle anticlockwise to draw the feed nut along the feed screw until the screw holes in the nut are aligned with those in the slide. Now install the screws (taken from the original nut) that retain the feed nut.

## 5. OPERATION

The lathe may now be operated as before, but with the accuracy and convenience of digital measurement. There are three buttons present on each display:

In/mm Switches display between inch and mm.  
ON/OFF Turns the unit on or off.  
ZERO Sets the display to 0.

- 5.1 Turn both displays on by pressing the ON/OFF button on each one.
- 5.2 Select the required unit of measurement for each display, using the In/mm buttons.
- 5.3 Set up the lathe as required and zero the displays using the ZERO buttons (the displays can be reset to 0 at any time)
- 5.4 When you are finished working on the lathe, turn both displays off by pressing the ON/OFF button on each one.

## 6. MAINTENANCE

- 6.1 The SM3002DFD requires little by way of maintenance. Keep the displays clean by occasionally wiping with a moist cloth - DO NOT use solvents or abrasives.
- 6.2 Should the display begin to fade during use, the batteries must be replaced. Each display requires one LR44 battery.
- 6.2.1 Remove the two screws (fig 21a) and the battery compartment cover (fig 21b)

fig 21

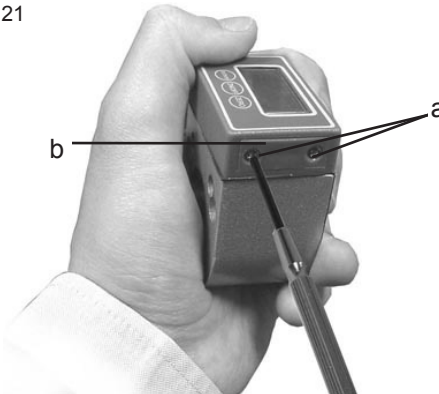

- 6.2.2 Gently pull the yellow tag to eject the battery.

fig 22



- 6.2.3 Insert a new battery (type LR44) into the battery compartment, with the positive (+) side facing up towards the LCD.

**NOTE:** It is our policy to continually improve products and as such we reserve the right to alter data, specifications and component parts without prior notice.

**IMPORTANT:** No liability is accepted for incorrect use of this product.

**WARRANTY:** Guarantee is 12 months from purchase date, proof of which will be required for any claim.



Sole UK Distributor, Sealey Group,  
Kempson Way, Suffolk Business Park,  
Bury St. Edmunds, Suffolk,  
IP32 7AR



01284 757500



01284 703534



www.sealey.co.uk



sales@sealey.co.uk