



INSTRUCTIONS FOR

Drilling/Milling Machine



MODEL: **SM25.V3**

Thank you for purchasing a Sealey product. Manufactured to a high standard this product will, if used according to these instructions and properly maintained, give you years of trouble free performance.

⚠ IMPORTANT: PLEASE READ THESE INSTRUCTIONS CAREFULLY. NOTE THE SAFE OPERATIONAL REQUIREMENTS, WARNINGS AND CAUTIONS. USE THIS PRODUCT CORRECTLY AND WITH CARE FOR THE PURPOSE FOR WHICH IT IS INTENDED. FAILURE TO DO SO MAY CAUSE DAMAGE AND/OR PERSONAL INJURY, AND WILL INVALIDATE THE WARRANTY. PLEASE KEEP INSTRUCTIONS SAFE FOR FUTURE USE.

The use of symbols in this document is to attract your attention to possible danger. The symbols and warnings themselves do not eliminate any danger, nor are they substitutes for proper accident prevention measures.

1. SAFETY INSTRUCTIONS

1.1. ELECTRICAL SAFETY

⚠ WARNING! It is the responsibility of the owner and the operator to read, understand and comply with the following:
 You must check all electrical products, before use, to ensure that they are safe. You must inspect power cables, plugs, sockets and any other connectors for wear or damage. You must ensure that the risk of electric shock is minimised by the installation of appropriate safety devices. A Residual Current Circuit Breaker (RCCB) should be incorporated in the main distribution board. We also recommend that a Residual Current Device (RCD) is used. It is particularly important to use an RCD with portable products that are plugged into a supply which is not protected by an RCCB. If in any doubt consult a qualified electrician. You may obtain a Residual Current Device by contacting your Sealey dealer.

You must also read and understand the following instructions concerning electrical safety.

- 1.1.1. The **Electricity at Work Act 1989** requires all portable electrical appliances, if used on business premises, to be tested by a qualified electrician, using a Portable Appliance Tester (PAT), at least once a year.
- 1.1.2. The **Health & Safety at Work Act 1974** makes owners of electrical appliances responsible for the safe condition of those appliances and the safety of the appliance operators. **If in any doubt about electrical safety, contact a qualified electrician.**
- 1.1.3. Ensure that the insulation on all cables and on the appliance is safe before connecting it to the power supply. See 1.1.1. and 1.1.2. and use a Portable Appliance Tester.
- 1.1.4. Ensure that cables are always protected against short circuit and overload.
- 1.1.5. Regularly inspect power supply cables and plugs for wear or damage and check all connections to ensure that none is loose.
- 1.1.6. **Important:** Ensure that the voltage marked on the appliance matches the power supply to be used and that the plug is fitted with the correct fuse - see fuse rating at right.
- 1.1.7. **DO NOT** pull or carry the appliance by the power cable.
- 1.1.8. **DO NOT** pull the plug from the socket by the cable.
- 1.1.9. **DO NOT** use worn or damaged cables, plugs or connectors. Immediately have any faulty item repaired or replaced by a qualified electrician. When a BS 1363/A UK 3 pin plug is damaged, cut the cable just above the plug and **dispose of the plug safely.**

Fit a new plug according to the following instructions (UK only).

- a) **Connect the GREEN/YELLOW earth wire to the earth terminal 'E'.**
- b) **Connect the BROWN live wire to the live terminal 'L'.**
- c) **Connect the BLUE neutral wire to the neutral terminal 'N'.**
- d) **After wiring, check that there are no bare wires, that all wires have been correctly connected, that the cable outer insulation extends beyond the cable restraint and that the restraint is tight.**

Double insulated products, which are always marked with this symbol , are fitted with live (brown) and neutral (blue) wires only. To rewire, connect the wires as indicated above - **DO NOT** connect either wire to the earth terminal.

- 1.1.10. Products which require more than 13 amps are supplied without a plug. In this case you must contact a qualified electrician to ensure that a suitably rated supply is available. We recommend that you discuss the installation of an industrial round pin plug and socket with your electrician.
- 1.1.11. If an extension reel is used it should be fully unwound before connection. A reel with an RCD fitted is preferred since any appliance plugged into it will be protected. The cable core section is important and should be at least 1.5mm², but to be absolutely sure that the capacity of the reel is suitable for this product and for others which may be used in the other output sockets, we recommend the use of 2.5mm² section cable.

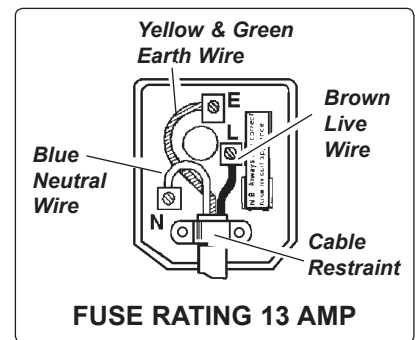

1.2 GENERAL SAFETY

- ⚠ WARNING!** Disconnect the drilling/milling machine from the mains power, and ensure the cutting tool or chuck is at a complete standstill before attempting to change accessories, service or perform any maintenance.
- ✓ Maintain the drilling/milling machine in good condition (use an authorised service agent).
- ✓ Replace or repair damaged parts. *Use recommended parts only. Unauthorised parts may be dangerous and will invalidate the warranty.*
- ✓ Locate the drilling/milling machine in a suitable area. Ensure the surface is flat and firm. Keep area clean and tidy and free from unrelated materials, and ensure there is adequate lighting.
- ✓ Keep the drilling/milling machine clean for best and safest performance and check moving parts alignment regularly.
- ⚠ WARNING!** Before each use check that drill/chuck/cutting tool is secure and that it is not worn or damaged. If worn or damaged replace immediately.
- ⚠ WARNING!** Keep guard and holding fixings in place, tight and in good working order. Check regularly for damaged parts.
 A guard, or any other part, that is damaged must be replaced with a new one, to ensure that it operates properly and performs its intended function, before the tool is used. The safety guard is a mandatory fitting where drilling/milling machine is used in premises covered by the Health & Safety at Work Act.
- ✓ Remove adjusting keys and wrenches from the machine and its vicinity before turning it on.
- ⚠ WARNING!** Wear approved safety eye protection, ear defenders, and, if dust is generated, respiratory protection.
- ✓ Remove ill fitting clothing. Remove ties, watches, rings and other loose jewellery and contain long hair.
- ✓ Keep hands and body clear of the work table when operating the drilling/milling machine.
- ✓ Maintain correct balance and footing. Ensure the floor is not slippery and wear non-slip shoes.
- ✓ Always clamp workpiece securely to the table or hold securely in a vice which is firmly mounted to the table. NEVER hold a workpiece by hand.
- ✓ Keep children and unauthorised persons away from the working area.

- ❑ **WARNING!** DO NOT switch the drilling/milling machine on whilst the drill or cutting tool is in contact with the workpiece. Bring the drill or cutting tool gradually to the workpiece. Avoid un-intentional starting of the drilling/milling machine.
- ✗ DO NOT use the drilling/milling machine for a task it is not designed to perform.
- ✗ DO NOT allow untrained persons to operate the drilling/milling machine.
- ✗ DO NOT get the drilling/milling machine wet or use in damp or wet locations or areas where there is condensation.
- ❑ **WARNING!** DO NOT use drilling/milling machine where there are flammable liquids, solids or gases such as petrol, paint solvents, waste wiping rags etc.
- ✗ DO NOT operate the drilling/milling machine if any parts are missing or damaged as this may cause failure and/or possible personal injury.
- ✗ DO NOT remove the safety guard whilst in use.
- ✗ DO NOT attempt to remove a workpiece until the drill or cutting tool has stopped rotating.
- ✗ DO NOT touch the workpiece close to the cut as it will be very hot. Allow to cool.
- ✗ DO NOT leave the drill or cutting tool operating unattended.
- ✗ DO NOT operate the drill or cutting tool when you are tired or under the influence of alcohol, drugs or intoxicating medication.
- ✓ When not in use switch the drilling/milling machine off and isolate from the power supply.

2. INTRODUCTION & SPECIFICATION

The SM25 is a bench or stand mounted drilling/milling machine with a 12 speed reversible drive giving flexibility to handle most materials. The table has a large surface area with inverted 'T' slots facilitating the securing of large and awkward shaped work pieces. The machine is supplied with metric graduated compound scales. Complies with Machinery Directive 98/37/EC and is fully CE approved. A 52 piece clamping kit is available as an optional extra, Model No.SM25/52T. The machine is supplied with 63mm face cutter, 90mm angle vice, 16mm drill chuck and safety guard. A stand is available as an optional extra, Model No. SM25/STAND.

Specification:

Drilling capacity	25mm
Swing	496mm
Face Mill capacity	63mm
End Mill capacity	13mm
Diameter of spindle sleeve	85mm
Head swivel	360°
Forward/Backward table travel:	145mm
Right/Left table travel	370mm
Table working area	585 x 190mm
Spindle nose taper	MT3

Spindle travel	92mm
Number of speeds	12
Speed range	100-2150rpm
Max. distance spindle to table	380mm
Max. distance spindle to base	480mm
Column diameter	92mm
Motor power750W
Supply	230V 50Hz 6.5A
Overall height	930mm
Weight	167kg
Optional stand	SM25/STAND

3. CONTENTS & ASSEMBLY

- **Contents description:**
- Drilling/milling machine.
- 3 Table handle wheels (7, 11, 13)
- 3 Table handles (7, 11, 13) with integral pivots.
- 3 Handle rods with knobs(3)
- 1 Punch key
- 1 Hex key (4mm)
- 1 Hex key (5mm)
- 1 Hex key (6mm)
- 1 Milling cutter with MT3 arbc
- 1 Drill chuck and key with MT
- 1 MT3 to MT2 conversion art
- 1 2-1/2" Angle vice
- 1 Head handle
- 1 Head handle grip with integral pivot.

❑ **WARNING!** For safe handling and movement use a fork-lift truck or pallet truck.

3.1 Unpack the product and check that all components and tools are present and undamaged. If any problem is noted contact your supplier immediately.

3.2 The machine has been coated with heavy grease to protect it in shipping. Remove the coating with commercial degreaser, kerosene or similar solvent before operating. Avoid getting the solvent on belts or other rubber parts. After degreasing coat the machined surfaces with a medium consistency machine oil.

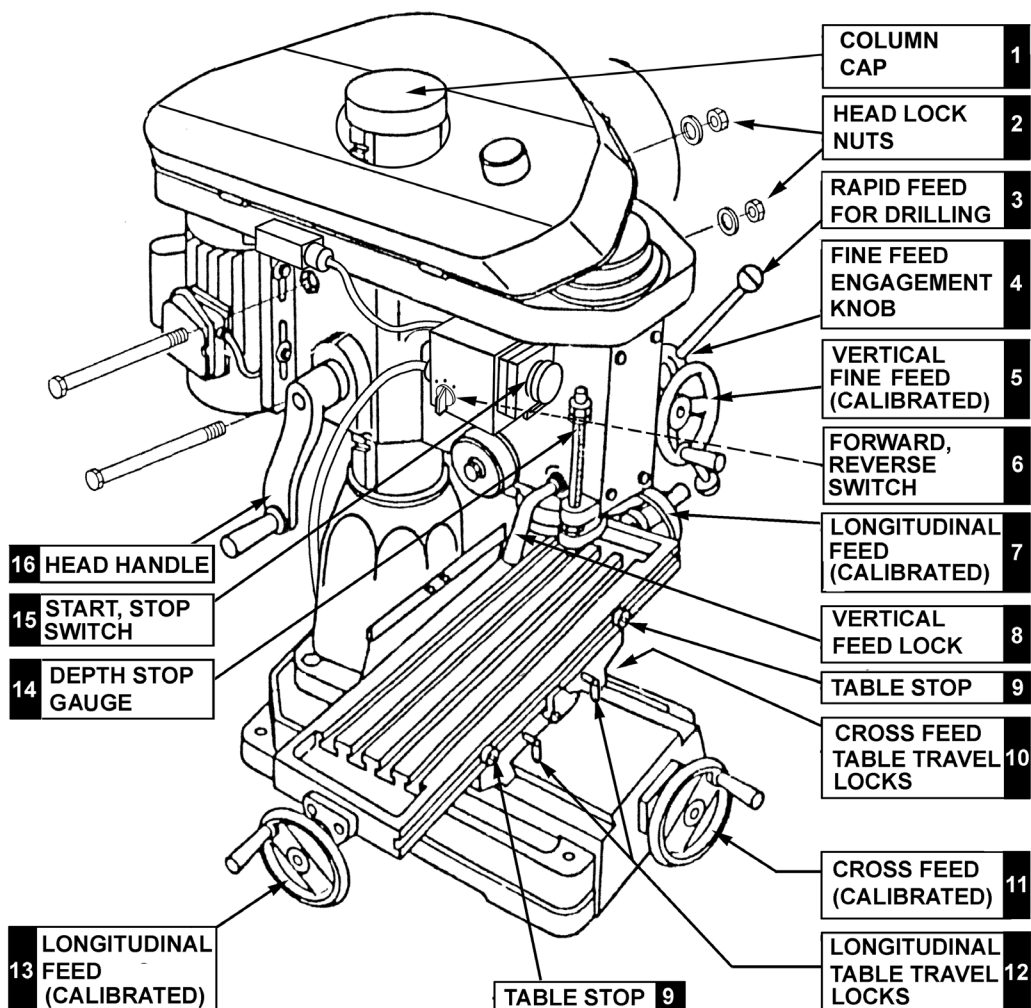

- 3.3. **Assembling Milling Feed Wheels.** Take the 3 handle grips with integral pivot rods and screw the threaded end of each rod into the threaded hole in each table handle wheel. Tighten each pivot into the wheel using a 7mm spanner across the flats on each pivot rod.
- 3.4. Slide one wheel onto the cross feed axle ensuring that the castellations on the wheel are fully engaged with the castellations on the axle and tighten the grub screw in the wheel collar down onto the axle with a small slotted screwdriver.
- 3.5. Attach the other two wheels to each end of the longitudinal feed table in the same way. (See fig1-7 & 1-13 & 1-11).
- 3.6. **Assembling Drilling Feed Wheel.** Identify the 3 chromed handle rods with black knobs attached. One end of each rod has flats on it. Screw this end into the drill feed hub on the right hand side of the head (See fig3-1) and tighten using a 12mm spanner.
- 3.7. **Assembling Head Handle.** Attach a handle grip with integral pivot rod to the head handle by screwing the threaded end of the rod into the threaded hole in the handle. Tighten the pivot rod into the handle using a 7mm spanner across the flats on the pivot rod. Note that the stub shaft sticking out of the left side of the main body of the machine to which the handle attaches has a flat machined across it. Push the head handle onto the shaft. Align the hex grub screw in the with the flat on the shaft and fully tighten using a 4mm hex key.

4. SET-UP AND OPERATION

WARNING! Before operating the drilling/milling machine ensure you are wearing approved safety goggles to protect you from swarf and metal particles. If using cutting oil or coolant a face mask may be necessary to avoid breathing any vapour generated. Ensure that all other safety instructions in chapter 1 are followed carefully.

- 4.1. **Head Adjustment.** To move the head up or down or to rotate it from side to side over the bed you must first loosen the head lock nuts (See fig.1-2). Move the head up or down using the head handle (See fig.1-16). Rotate the head over the bed if required and then retighten the nuts.
- 4.2. **Speed Adjustment.** The table below shows the speeds obtained using different belt combinations. Use a speed appropriate to the metal you are cutting/drilling. *Disconnect the machine from the power supply before changing speeds.*
 - 4.2.1 To access the drive belts raise the whole head using the head handle until the top surface of the pulley cover is level with the top of the black cap on top of the pillar. Unlock the pulley cover by undoing the two catches on the right hand side of the cover and raise the cover clear of the main pillar.
 - 4.2.2 Loosen the motor leaf screw (See fig.2-D) and push the motor towards the main pillar of the machine in order to loosen the motor belt. To loosen the other belt slacken off the two bolts holding the central pulley base plate. These are situated either side of the main pillar. (See fig.2-E)
 - 4.2.3 Move the belts to the desired positions and retension them by pushing the motor away from the main pillar. Tighten the motor leaf screw first. Then retighten the two bolts holding the central pulley base plate.
 - 4.2.4 Close and lock the pulley cover ensuring that the clearance slide is pushed back into its position within the cover.

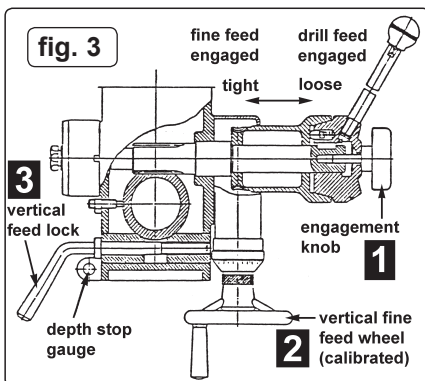
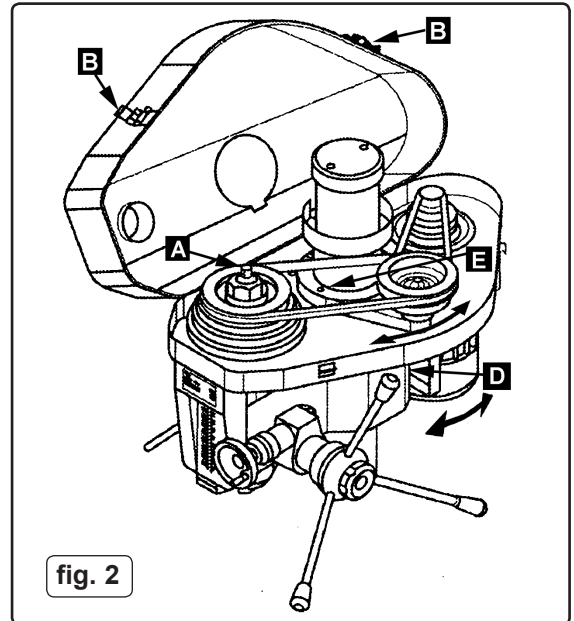

SPINDLE SPEEDS			
MILL/DRILL SPINDLE		MOTOR	
	4	A	600
	3	B	700
	2	C	950
	1	D	1290
A-1	100	B-4	600
B-1	170	C-3	700
A-2	200	C-4	950
A-3	250	D-2	1290
C-1	280	D-3	1590
B-2	360	D-4	2150

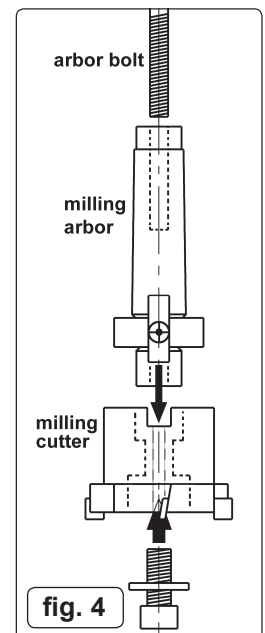

4.3 SETTING UP FOR MILLING. (Disconnect the machine from the power supply while setting up.)

- 4.3.1 **Engaging vertical fine feed.** Before commencing milling you should engage the vertical fine feed wheel (See fig.3-2) by fully tightening the engagement knob mounted on the outside of the drill feed hub. (See fig.3-1) (This will at the same time disable the rapid drill feed.) Set the depth stop to its maximum so that it does not interfere with downward movement when setting the height of the milling tool.
- 4.3.2 **Mounting the Cutting Tool.** If the drill chuck and arbor are currently mounted, remove them by loosening the arbor bolt by two turns and giving it a tap with a rubber mallet. The arbor bolt appears at the top of the spindle shaft and can be accessed by raising the pulley cover (See fig.2-A). Ensure that the drill chuck and arbor are supported as they are removed.
- 4.3.3 **Wear protective gloves at all times especially when handling the cutter.** Bolt the cutting tool to the milling arbor as shown in fig.4 using the hex bolt and washer supplied. Tighten with an 8mm hex key. Introduce the cutter assembly into the spindle sleeve and hold it in place whilst the arbor bolt is tightened by hand. Hold the spindle pulley stationary with one hand and tighten the arbor bolt with a spanner. Do not overtighten.
- 4.3.4 **Attaching the workpiece.** The main bed of the machine has 4 inverted 'T' slots in it for fixing the workpiece or any vice/clamping arrangement used to hold the workpiece. The dimensions of the slots are shown in fig.5 in order to choose appropriate fixings. A 52 piece clamping kit is available as an optional extra. Part No. SM25/52T.
- 4.3.5 **Setting and locking the cutter height.** Once the workpiece is in place the cutter can be lowered to the required cutting height using the vertical fine feed hand wheel. The height setting must then be locked using the feed lock handle situated next to the depth gauge (See fig.3-3).

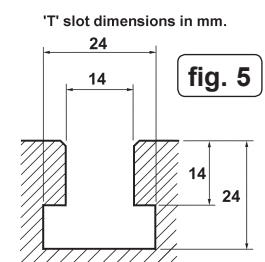

4.3.6 **Locking table travel.** To eliminate the possibility of inadvertently moving one feed whilst operating the other you should lock the table feed not being used. To lock the longitudinal table tighten the two leaf screws on the front of the table (See fig.6-12). To lock the cross feed table tighten the two thumb screws on the right hand side of the cross feed table (See fig.6-10 and fig.7).

4.3.7 **Longitudinal feed stops.** In order to control the length of cut there are two adjustable stops situated on the front of the longitudinal table. (See fig.6-9). These stops should be adjusted in relation to the central fixed stop. (See fig.6-17). Loosen the adjustable stops with the 5mm hex key provided. Slide the stop to the required position and retighten.

4.3.8 **Calibrated feed.** Each feed wheel has an adjustable calibration ring.

4.3.9 The calibration rings for the cross feed and longitudinal feed are marked in increments of 0.05mm. One 360° rotation of each wheel advances the bed through a distance of 2.5mm. Each ring has a thumb screw which allows it to be reset to zero or any mark required for a specific cut.

4.3.10 The vertical fine feed has a calibration ring marked in increments of 0.05mm. One 360° rotation of this wheel will raise or lower the cutter through a distance of 2.5mm. Move the calibration ring for the purposes of a specific cut using the thumbscrew provided.

4.3.11 Avoid subjecting drills and cutting tools to excessive strain. Do not apply undue force on the handle in order to cut workpiece. Maintain a controlled cutting speed through the workpiece.

4.3.12 **Adjustable Guard.** After the workpiece has been fixed in place on the bed, but before switching on, swing the clear plastic guard (See fig.6-18) round so that it is between your line of sight and the workpiece. Adjust the height of the guard using the two black knurled knobs on the left hand side of the guard.

4.3.13 **Forward/reverse switch.** Set the direction of spindle rotation before operating the main on/off switch. The forward/reverse switch is situated on the left hand side of the main on/off switch mounting box (See fig.1-6). The switch has 3 positions. The central position marked '0' is 'OFF'. By turning the switch to the 'R' position the spindle shaft will run anticlockwise. By turning the switch to the 'F' position the spindle shaft will run clockwise. If the switch is returned to the central OFF position whilst the motor is running the main ON/OFF switch automatically cuts off the power. Allow the machine to come to a complete standstill before changing the direction of rotation.

4.3.14 **Main ON/OFF switch with emergency shut off.** The main ON/OFF switch arrangement is situated on the left hand side of the head. (See fig.1-15). The switch consists of the conventional green ON button and adjacent red OFF button beneath a latching, yellow, outer cover which carries a large, red emergency shut off button. To access the start button when the outer cover is latched push the emergency button upwards in the direction of the arrow to release the cover. Hinge the cover upwards and operate the green start button. To switch the machine off, lift the cover and press the stop button. Alternatively, hit the emergency button which will automatically lock the outer cover and operate the OFF button beneath it.

4.4 SETTING UP FOR DRILLING. (Disconnect the machine from the power supply while setting up)

4.4.1 **Vertical feed lock.** Before drilling, ensure that the vertical feed is not locked. The feed lock lever should be loose. (See fig.1-8)

4.4.2 **Engaging rapid drill feed.** The rapid drill feed is controlled with the three rods emerging from the hub on the right hand side of the head. (See fig.3-1) The rapid drill feed will not operate if the vertical fine feed wheel used for milling is still engaged. To make the rapid drill feed operative loosen the engagement knob mounted on the outside of the drill feed hub. (See fig.3-1) Rotate the hub back and forth to ensure that the hub springs fully outwards.

4.4.3 **Depth stop gauge.** The depth stop gauge (See fig.1-14) has a graduated scale allowing the drilling depth to be set. Rotate the primary nut down to the required depth mark and lock it in place with the secondary nut. Alternatively, wind the drill bit down to the required depth then rotate the primary nut down to the depth stop on the casting and lock it with the secondary nut.

4.4.4 **Mounting the chuck with MT3 arbor.** If the milling cutter and arbor are currently mounted, remove them by loosening the arbor bolt by two turns and giving it a tap with a rubber mallet. The arbor bolt appears at the top of the spindle shaft and can be accessed by raising the pulley cover (See fig.2-A). Ensure that the milling cutter and arbor are supported as they are removed (**Wear protective gloves.**) The drill chuck is a shallow taper fit into the end of the spindle shaft. Insert the chuck arbor into the bottom of the spindle shaft and retain it with the arbor bolt. Do not over tighten.

4.4.5 **Mounting a chuck or drill with an MT2 taper.** The spindle shaft has an MT3 internal taper into which both the milling cutter and the drilling chuck can be directly inserted. The arbors are held in place with the long arbor bolt which is accessible when the top cover is raised (See Fig.2A). When a smaller MT2 taper is required a conversion arbor can be fitted which is MT3 externally but MT2 internally. When this sleeve is fitted the long arbor bolt cannot be used and should be removed. The arbor will be held in place by the taper. Insert an appropriate chuck or taper drill. Bring the tip of the drill or chuck to bear on a piece of wood placed onto the table and exert firm but not excessive downward pressure on the drill to retain it in the taper. To remove the MT2 conversion arbor, wind the rack sleeve down until the slot in the side of it becomes visible. Insert the punch key into the slot and slide it over the top of the conversion sleeve. A light blow with a mallet should then dislodge the sleeve. Wear protective gloves and support the sleeve as it becomes loose.

4.4.6 **Attaching the workpiece.** The main bed of the machine has 4 inverted 'T' slots in it for fixing the workpiece or any vice/clamping arrangement used to hold the workpiece. The dimensions of the slots are shown in fig.5 in order to choose appropriate fixings. A 52 piece clamping kit is available as an optional extra. Part No. SM25/52T.

4.4.7 **Speed and direction of rotation.** Set an appropriate speed for the drilling operation as described in Section 4.2. Before switching on set the forward/reverse switch to the 'F' position so that the drill bit is turning clockwise. Refer to Section 4.3.13

4.4.8 **Switching on.** Refer to Section 4.3.14 for the operation of the main ON/OFF switch.

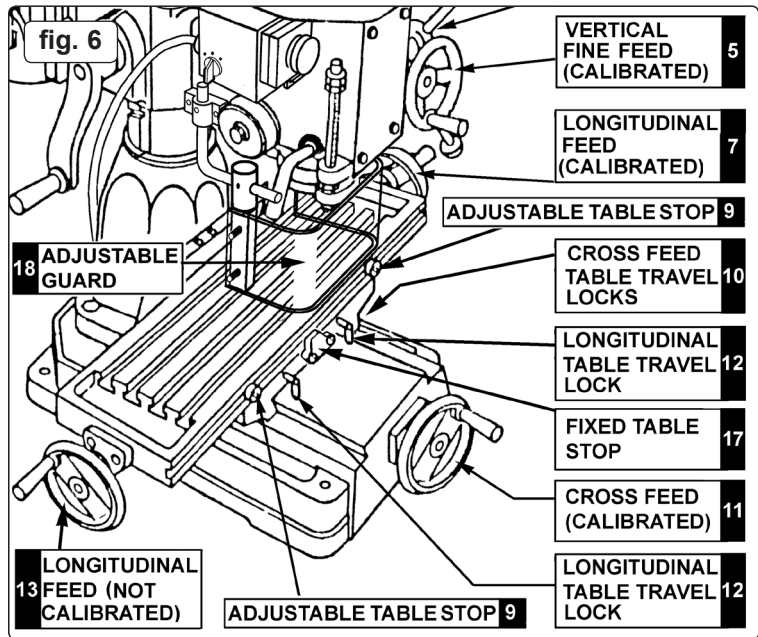

5. MAINTENANCE

- **WARNING!** Ensure the drilling/milling machine is unplugged from the mains power supply before attempting any maintenance.
- 5.1. Lubricate the machine before every use. See lubrication points on fig.8.
- 5.2. Clean the machine after each use.
- 5.3. Clean and coat the cross lead screw with oil weekly.
- 5.4. Lubricate the bearing,worm and worm shaft monthly.
- 5.5. Check that the table is horizontal once a year.
- 5.6. Adjust the accuracy of the cross and longitudinal feeds monthly. Any wear or slack can be taken up by adjusting the position of the Gib strip for both the longitudinal and cross feeds. To do this place a large screwdriver into the slot in either Gib strip bolt (see fig.7) and rotate it clockwise until the movement of the table begins to be restricted. Then back the bolt off until only a slight drag is felt on the movement.

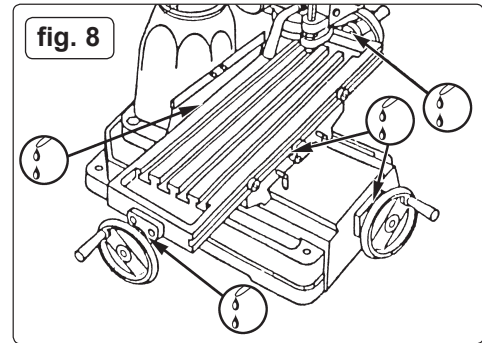
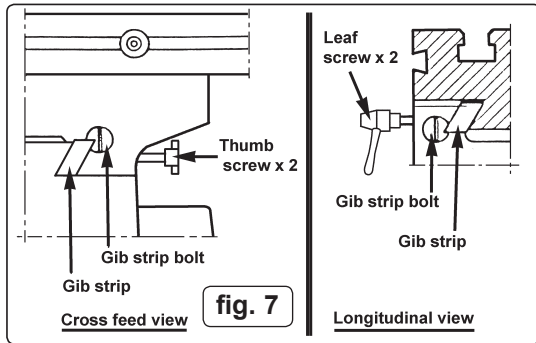

6. TROUBLESHOOTING

SYMPTOM	POSSIBLE CAUSE	CORRECTIVE ACTION
Motor overheats / no power	Feed is too fast. Faulty switch or motor. Pulley belt tension is too high.	Decrease feed speed. Replace faulty part. (See parts list). Decrease the tension. (Refer to section 4.2).
Spindle bearing getting hot.	No lubrication. Spindle bearing too tight.	Apply grease. Loosen the bearing.
Unbalanced table travel.	Excessive play in table movement. Cut depth too deep for cutting tool.	Adjust the Gib bolts. (Refer to fig.7). Decrease the depth of the cut.
Spindle shakes during use.	Spindle bearing gap is too wide. The chuck is loose. Cutter is blunt. Workpiece is loose.	Reduce the gap or replace the bearing. Re-seat the chuck in the arbor. Sharpen or replace the cutter. Secure the workpiece.
Vertical fine feed not functioning.	Clutch is loose. Worm and worm shaft are worn. Hand wheel fixing is loose.	Tighten the clutch. Replace worn parts. (See parts list). Realign and tighten fixing.

NOTE: It is our policy to continually improve products and as such we reserve the right to alter data, specifications and component parts without prior notice.

IMPORTANT: No liability is accepted for incorrect use of this product.

WARRANTY: Guarantee is 12 months from purchase date, proof of which will be required for any claim.

INFORMATION: For a copy of our latest catalogue and promotions call us on 01284 757525 and leave your full name and address, including postcode.



Sole UK Distributor, Sealey Group,
Kempson Way, Suffolk Business Park,
Bury St. Edmunds, Suffolk,
IP32 7AR



01284 757500



www.sealey.co.uk



01284 703534



sales@sealey.co.uk