

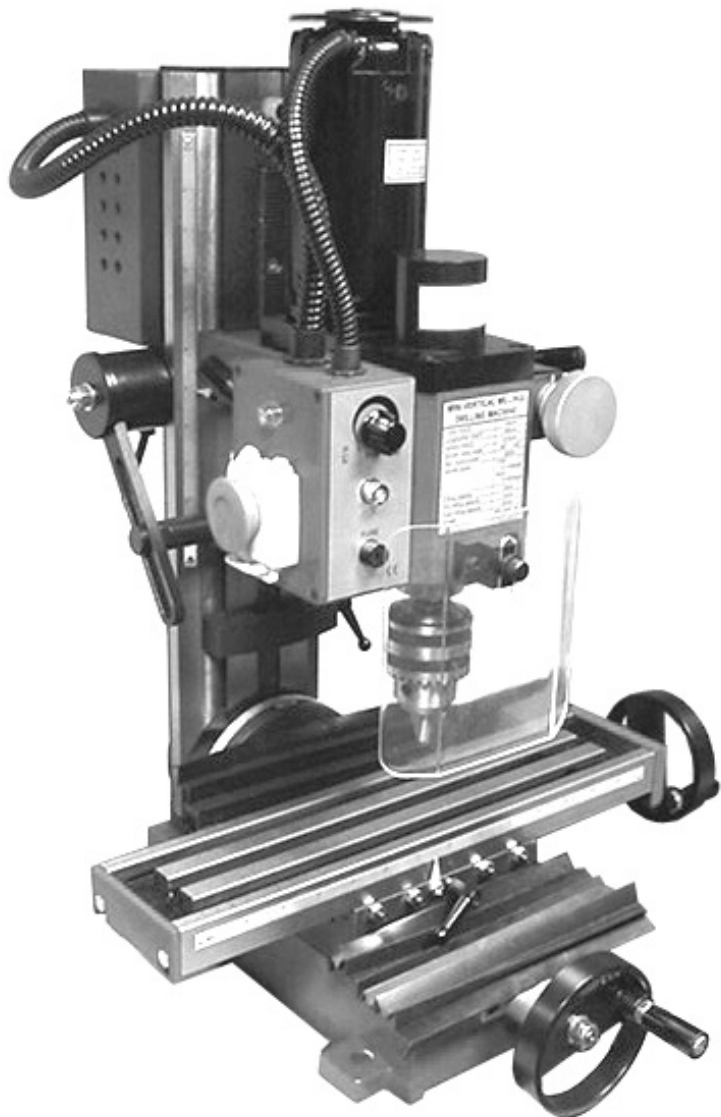

INSTRUCTIONS FOR Mini Drilling/Milling Machine



MODEL NO: SM2502



INSTRUCTIONS FOR:
MINI DRILLING/MILLING MACHINE
MODEL NO: **SM2502**

Thank you for purchasing a Sealey product. Manufactured to a high standard, this product will, if used according to these instructions and maintained properly, give you years of trouble free performance.

IMPORTANT: PLEASE READ THESE INSTRUCTIONS CAREFULLY. NOTE THE SAFE OPERATIONAL REQUIREMENTS, WARNINGS & CAUTIONS. USE THE PRODUCT CORRECTLY AND WITH CARE FOR THE PURPOSE FOR WHICH IT IS INTENDED. FAILURE TO DO SO MAY CAUSE DAMAGE AND/OR PERSONAL INJURY AND WILL INVALIDATE THE WARRANTY. KEEP THESE INSTRUCTIONS SAFE FOR FUTURE USE.



Refer to instruction manual



Wear eye protection



Wear ear protection



Wear protective clothing

1. SAFETY

1.1. ELECTRICAL SAFETY

WARNING! It is the responsibility of the owner and the operator to read, understand and comply with the following:

You must check all electrical products, before use, to ensure that they are safe. You must inspect power cables, plugs, sockets and any other connectors for wear or damage. You must ensure that the risk of electric shock is minimised by the installation of appropriate safety devices. A Residual Current Circuit Breaker (RCCB) should be incorporated in the main distribution board. We also recommend that a Residual Current Device (RCD) is used. It is particularly important to use an RCD with portable products that are plugged into a supply which is not protected by an RCCB. If in any doubt consult a qualified electrician. You may obtain a Residual Current Device by contacting your Sealey dealer.

You must also read and understand the following instructions concerning electrical safety.

- 1.1.1. The **Electricity at Work Act 1989** requires all portable electrical appliances, if used on business premises, to be tested by a qualified electrician, using a Portable Appliance Tester (PAT), at least once a year.
- 1.1.2. The **Health & Safety at Work Act 1974** makes owners of electrical appliances responsible for the safe condition of those appliances and the safety of the appliance operators. **If in any doubt about electrical safety, contact a qualified electrician.**
- 1.1.3. Ensure that the insulation on all cables and on the appliance is safe before connecting it to the power supply. See 1.1.1. and 1.1.2. and use a Portable Appliance Tester.
- 1.1.4. Ensure that cables are always protected against short circuit and overload.
- 1.1.5. Regularly inspect power supply cables and plugs for wear or damage and check all connections to ensure that none is loose.
- 1.1.6. **Important:** Ensure that the voltage marked on the appliance matches the power supply to be used and that the plug is fitted with the correct fuse - see fuse rating at right.
- 1.1.7. **DO NOT** pull or carry the appliance by the power cable.
- 1.1.8. **DO NOT** pull the plug from the socket by the cable.
- 1.1.9. **DO NOT** use worn or damaged cables, plugs or connectors. Immediately have any faulty item repaired or replaced by a qualified electrician. When a BS 1363/A UK 3 pin plug is damaged, cut the cable just above the plug and **dispose of the plug safely.** Fit a new plug according to the following instructions (UK only).
 - a) **Connect the GREEN/YELLOW earth wire to the earth terminal 'E'.**
 - b) **Connect the BROWN live wire to the live terminal 'L'.**
 - c) **Connect the BLUE neutral wire to the neutral terminal 'N'.**
 - d) **After wiring, check that there are no bare wires, that all wires have been correctly connected, that the cable outer insulation extends beyond the cable restraint and that the restraint is tight.**
- 1.1.10. If an extension reel is used it should be fully unwound before connection. A reel with an RCD fitted is preferred since any appliance plugged into it will be protected. The cable core section is important and should be at least 1.5mm², but to be absolutely sure that the capacity of the reel is suitable for this product and for others which may be used in the other output sockets, we recommend the use of 2.5mm² section cable.

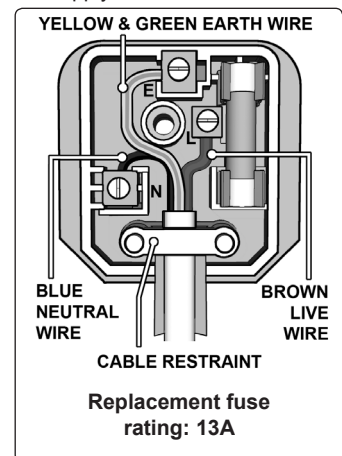

1.2 GENERAL SAFETY

- ❑ **WARNING!** Disconnect the drilling/milling machine from the mains power, and ensure the cutting tool or chuck is at a complete standstill before attempting to change accessories, service or perform any maintenance.
- ✓ Maintain the drilling/milling machine in good condition (use an authorised service agent).
- ✓ Replace or repair damaged parts. *Use recommended parts only. Unauthorised parts may be dangerous and will invalidate the warranty.*
- ✓ Locate the drilling/milling machine in a suitable area. Ensure the surface is flat and firm. Keep area clean and tidy and free from unrelated materials, and ensure there is adequate lighting.
- ✓ Keep the drilling/milling machine clean for best and safest performance and check moving parts alignment regularly.
- ❑ **WARNING!** Before each use check that drill/chuck/cutting tool is secure and that it is not worn or damaged. If worn or damaged replace immediately.
- ❑ **WARNING!** Keep guard and holding fixings in place, tight and in good working order. Check regularly for damaged parts.
A guard, or any other part, that is damaged must be replaced with a new one, to ensure that it operates properly and performs its intended function, before the tool is used. The safety guard is a mandatory fitting where drilling/milling machine is used in premises covered by the Health & Safety at Work Act.
- ✓ Remove adjusting keys and wrenches from the machine and its vicinity before turning it on.
- ❑ **WARNING!** Wear approved safety eye protection and, if oil mist is generated, respiratory protection.
- ✓ Remove ill fitting clothing. Remove ties, watches, rings and other loose jewellery and contain long hair.
- ✓ Keep hands and body clear of the work table when operating the drilling/milling machine.
- ✓ Maintain correct balance and footing. Ensure the floor is not slippery and wear non-slip shoes.
- ✓ Always clamp workpiece securely to the table or hold securely in a vice which is firmly mounted to the table. NEVER hold a workpiece by hand.
- ✓ Keep children and unauthorised persons away from the working area.
- ❑ **WARNING! DO NOT** switch the drilling/milling machine on whilst the drill or cutting tool is in contact with the workpiece. Bring the drill or cutting tool gradually to the workpiece. Avoid un-intentional starting of the drilling/milling machine.
- x **DO NOT** force the drilling/milling machine to achieve a task it was not designed to perform.
- x **DO NOT** allow untrained persons to operate the drilling/milling machine.
- x **DO NOT** get the drilling/milling machine wet or use in damp or wet locations or areas where there is condensation.
- ❑ **WARNING! DO NOT** use drilling/milling machine where there are flammable liquids, solids or gases such as petrol, paint solvents, waste wiping rags etc.
- x **DO NOT** operate the drilling/milling machine if any parts are missing or damaged as this may cause failure and/or possible personal injury.
- x **DO NOT** remove the safety guard whilst in use.
- x **DO NOT** attempt to remove a workpiece until the drill or cutting tool has stopped rotating.
- x **DO NOT** touch the workpiece close to the cut as it will be very hot. Allow to cool.
- x **DO NOT** leave the drill or cutting tool operating unattended.
- x **DO NOT** operate the drill or cutting tool when you are tired or under the influence of alcohol, drugs or intoxicating medication.
- ✓ When not in use switch the drilling/milling machine off and isolate from the power supply.

2. INTRODUCTION & SPECIFICATION

Bench mounting mini drilling/milling machine with the flexibility to handle most materials. Features include a 350W motor, variable speed drive, working table with T-slots to enable clamping of workpieces and Metric graduated compound scales. The machine also incorporates a tilting column which allows drilling/milling of workpiece at $\pm 45^\circ$ from vertical. Supplied with 13mm chuck accessory kit for adjusting and setting. An optional stand is available, order Model No. SM3002ST. See below for a comprehensive range of accessories.

Specification:

Drilling capacity	13mm
Face Mill capacity	30mm
End Mill capacity	16mm
Headstock travel (Z)	180mm
Cross axis (X)	100mm
Longitudinal axis (Y)	220mm
Spindle rotary angle	$-45^\circ / +45^\circ$
Output power	350Watts
Spindle taper	MT3

Spindle speed - Low range	0 to 1100 rpm + or - 10%
Spindle speed - High range	0 to 2500 rpm + or - 10%
T - slot	12mm
Weight (Net/gross)	50/68kg
Packing size	560 x 500 x 740mm

3. CONTENTS & ASSEMBLY

Contents / accessories description:(fig.1)

- Mini drilling/milling machine.
- 1. Large wrench
- 2. Drill chuck and taper shank
- 3. Oil can
- 4. Locking pin
- 5. 4 Hex keys (3,4,5,6mm)
- 6. Socket head wrench
- 7. 3 double ended spanners 8-10,14-17,17-19
- 8. Chuck key.
- 9. 2 Handles
- 10. 'T' nuts
- 11. Fuse
- 12. Draw bar

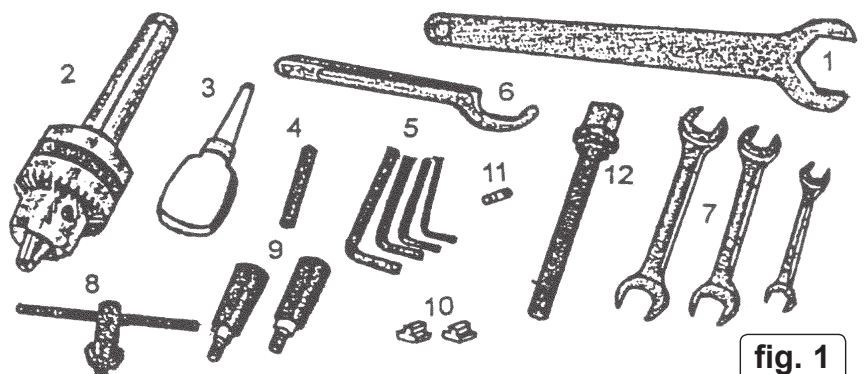
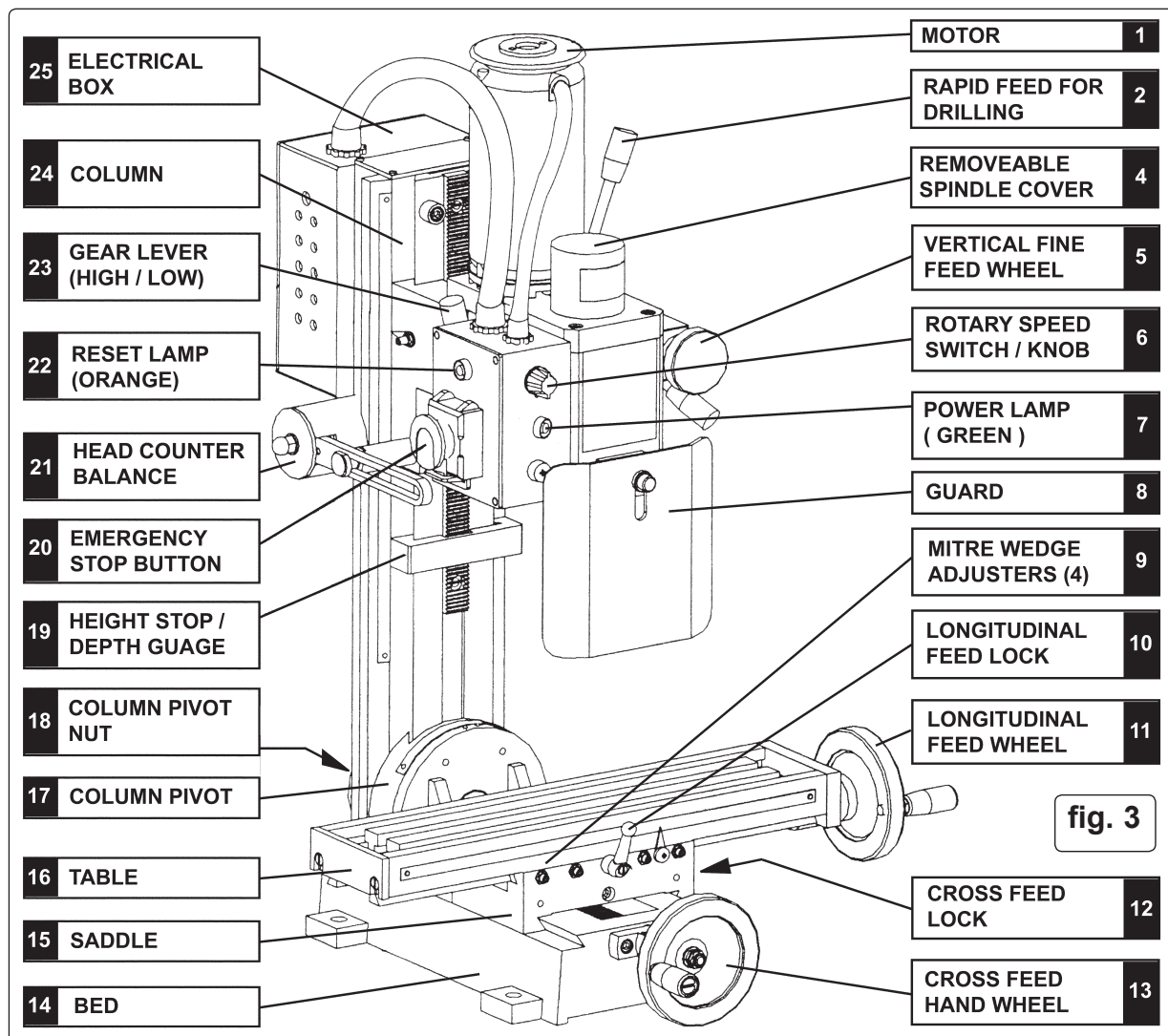
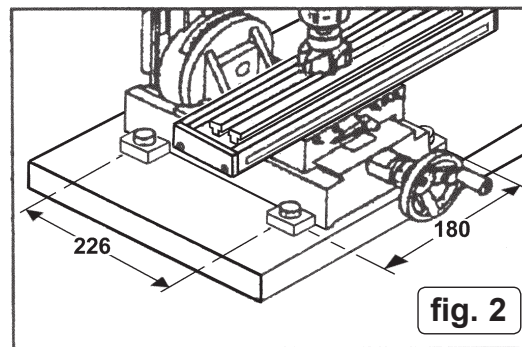

fig. 1

- ❑ **WARNING! At least two people will be required to move the machine. Observe good lifting practice.**
 - 3.1. Unpack the product and check that all components and tools are present and undamaged. If any problem is noted contact your supplier immediately.
 - 3.2. The machine has been coated with heavy grease to protect it in shipping. Remove the coating with commercial degreaser, kerosene or similar solvent before operating. Avoid getting the solvent on rubber parts. After degreasing coat the machined surfaces with a medium consistency machine oil.
 - 3.3. **Mounting the machine.** Locate the machine on a flat, level and strong work surface. Do not locate in direct sunlight or where heavy dust or moisture is present.
 - 3.4. Before finalising the mounting position consider the full extent of travel of the longitudinal table leaving clearance for the operators hand. Also consider access to the column pivot bolt and the tilting of the column to 45° in either direction.
- Drill the location holes in accordance with the dimensions shown in fig.2 and bolt the machine to the bench using four M10 nuts and bolts (Not provided).



4. SET- UP AND OPERATION

- ❑ **WARNING:** Before operating the drilling/milling machine ensure you are wearing approved safety goggles and gloves to protect you from swarf and metal particles. If using cutting oil or coolant a face mask may be necessary to avoid breathing any vapour generated. Ensure that all other safety instructions in section 1 are followed carefully.
- 4.1. Setting up for Milling. (Disconnect the machine from the power supply while setting up.) The machine is supplied without milling attachments. (See section 8 for details.) Contact your local Sealey dealer for a full range of accessories.
- 4.2. Engaging vertical fine feed. Prior to milling, activate the fine feed wheel (see fig.3-5) by pushing the drill feed hub inwards toward the body of the machine so that the two sets of castellations on the hub shaft engage together and lock the movement of the drill feed. (See fig.4) This action automatically engages the fine feed wheel. Set the depth stop to its maximum so that it does not interfere with downward movement when setting the height of the milling tool. (See fig.3-19)
- 4.3. Mounting the Cutting Tool. If the drill chuck and arbor are currently mounted, remove them by loosening the nut on the arbor bolt by two turns and giving it a tap with a rubber mallet. (The arbor bolt appears at the top of the spindle shaft and can be accessed by pulling off the plastic cap (See figs.3-4 and 4-A). Ensure that the drill chuck and arbor are supported as they are removed.
- 4.3.1. Select the cutting tool for the work in hand and the appropriate arbor or collet. **Wear protective gloves at all times especially when handling the cutter.** Introduce the cutter assembly into the spindle sleeve and hold it in place whilst the arbor nut and bolt are tightened by hand. Insert the locking pin provided into the hole in the right hand side of the head adjacent to the spindle (See fig.4-D) to prevent the spindle rotating. Tighten the arbor bolt with a spanner (do not overtighten). Remove the locking pin and replace the plastic cap.

- 4.4. **Attaching the workpiece.** The main bed of the machine has 3 inverted 'T' slots in it for fixing the workpiece or any vice/clamping arrangement used to hold the workpiece. The dimensions of the 'T' slots and 'T' nuts are shown in fig.5. A 42 piece clamping kit is available as an optional extra. Part No. SM2502CK.
- 4.5. Setting and locking the cutter height. Once the workpiece is in place the rapid drill feed can be used to bring the cutter closer to the workpiece but the final setting of the cutter height must be done with the fine feed wheel. To ensure accuracy during milling the cutter height setting must then be locked by tightening the head lock lever. (see fig.9)
- 4.6. Locking table travel. To eliminate the possibility of inadvertently moving one feed whilst operating the other you should lock the table feed not being used. To lock the longitudinal table tighten the longitudinal feed lock lever on the front of the table (See fig.3-10). To lock the cross feed table tighten the cross feed lock lever to be found on the right hand side of the saddle. (See fig.3-12).
- 4.7. Setting the column angle. If required, the column carrying the head can be pivoted and locked at any angle between vertical and 45° in either direction as indicated in fig.6. Before loosening the pivot bolt (See fig.7) the weight of the column must be firmly supported, preferably by a second person. Once the bolt is loose, lower the column to the required angle with reference to the scale provided and fully tighten the bolt.

❑ **WARNING.** Support the column at all times during this procedure as once the pivot bolt is loose the head could fall suddenly in either direction causing damage to the machine, associated equipment, or injury to persons.

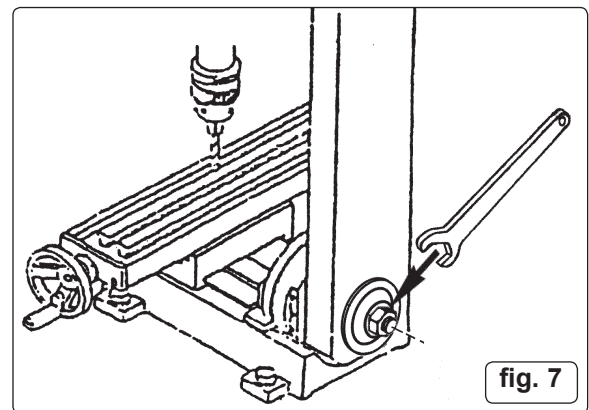
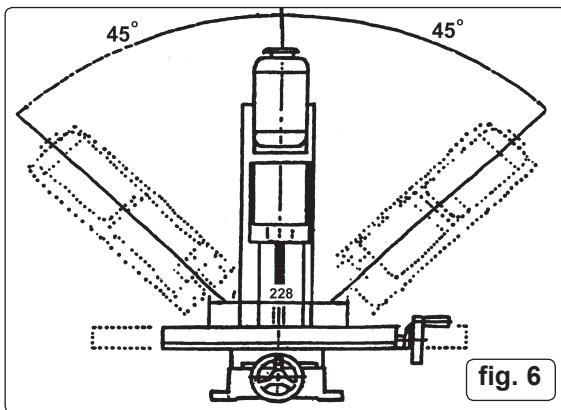
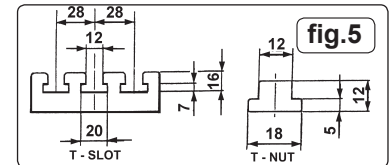
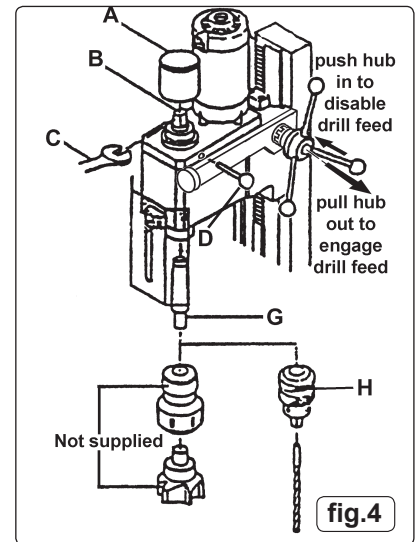

- 4.8. **Calibrated feed.** Each feed wheel has an adjustable calibration ring situated on the feed shaft immediately behind the wheel. The rings can be rotated by hand to the desired mark.
- 4.8.1. The calibration rings for each of the three feeds are marked in increments of 0.025mm. There are 60 increments to one full rotation of each feed wheel. One full rotation of a feed wheel will advance the cutter 1.5mm. Each ring can be rotated allowing it to be reset to zero or any mark required for a specific cut. The linear scales on the machine are marked in millimetres.
- 4.8.2. Avoid subjecting drills and cutting tools to excessive strain. Do not apply undue force on the handle in order to cut the workpiece. Maintain a controlled cutting speed through the workpiece.
- 4.9. **Safety Guard.** After the workpiece has been fixed in place on the bed, but before switching on, ensure that the clear plastic guard (See fig.3-8) is fixed in place.
- 4.10. **Select high or low gear.** The gear lever is situated on the left hand side of the head and selects either high or low gear.(see fig.8-D) Select low gear (0 to 1100 rpm) by pushing the lever towards the back of the machine. Select high gear (0 to 2500 rpm) by pulling the lever towards the front of the machine. **WARNING! Do not attempt to change gear whilst the machine is operating as this will result in damage to the gearbox. Only change gear when the machine is at a complete standstill.** As a general rule of thumb harder materials will require a lower milling/drilling speed. The speed is infinitely variable within each gear and is controlled by the rotary knob on the control box. See the next section for detailed operation of the speed control.
- 4.11. **Main ON/OFF switch with speed control and emergency shut off.** Connect the machine to the mains power.
- 4.12. The rotary speed control must be set in the 'I' position otherwise the machine will not start. If it is not in this position rotate the knob anticlockwise until it clicks and stops. (see fig.3-6)
- 4.13. Release the emergency 'OFF' switch cover by pushing the large button upwards to release the latch on the yellow housing. (fig.3-20) Hinge the cover upwards to reveal the red 'off' button for every day use. The green lamp under the rotary speed switch will now be illuminated indicating that the machine can now be switched on. (see fig.3-7)
- 4.14. Rotate the rotary speed switch slowly clockwise. As the knob is turned a click will be heard and the motor will start. As the knob is turned further the speed will increase. Set the knob to the desired speed.
- 4.15. **Stop modes.** There are three 'stop' modes as described below.
 (A). To stop the machine for a short while and then restart, simply return the rotary speed switch to the 'I' position. When you are ready to restart, rotate the switch clockwise to the desired speed.
 (B) When the yellow emergency stop cover is open the machine can be stopped by pressing the smaller red stop button within the yellow housing. When this button is used an orange reset light will illuminate on the side of the switch box. This means that the rotary speed switch must be returned to the 'I' position before you can restart the machine.
 (C) In an emergency hit the large red emergency button which automatically shuts the yellow cover and cuts the electrical supply to the machine. Before the machine will start again the rotary speed switch must be returned to the 'I' position and the emergency switch cover must be released by pushing the large red button upwards.

5.0. SETTING UP FOR DRILLING.

(Disconnect the machine from the power supply while setting up.)

- 5.1. **Engaging rapid drill feed.** The rapid drill feed is controlled with the three rods emerging from the hub on the right hand side of the head. (See fig.3-2) The rapid drill feed will not operate if the vertical fine feed wheel used for milling is still engaged. To make the rapid drill feed operative take hold of the central hub and pull it outwards to disengage the castellations on the hubs central shaft. (See also fig.4)
- 5.2. **Depth stop gauge.** The depth stop gauge (See fig.8-C) consists of a lockable bar which can be slid up and down the main column beneath the head. The depth stop can be set in relation to the graduated scale attached to the side of the main column. Alternatively, set the drilling depth using the rapid drill feed then move the depth stop up to the head and lock it with the lever. (see fig.8-A)
- 5.3. **Mounting the chuck and arbor.** If the milling cutter and arbor are currently mounted, remove them by loosening the arbor bolt by two turns and giving it a tap with a rubber mallet. The arbor bolt appears at the top of the spindle shaft and can be accessed by removing the cap. (See fig.3-4 & 4-A). Ensure that the milling cutter and arbor are supported as they are removed (**Wear protective gloves.**) Insert the chuck arbor into the bottom of the spindle shaft and retain it with the arbor bolt. Do not over tighten. The drill chuck is a shallow taper fit onto the end of the drilling arbor. Using the chuck key open the jaws of the chuck until they withdraw inside the chuck body. Place a piece of wood onto the bed and position the chuck on it below the spindle shaft. Using the drill feed, wind the spindle shaft down until the arbor enters the chuck. Exert firm but not excessive downward pressure on the chuck to retain it on the arbor.
- 5.4. **Drill bits.** (Not supplied) Insert an appropriate drill bit into the chuck and tighten the chuck with the chuck key.
- 5.5. **Attaching the workpiece.** The main bed of the machine has 3 inverted 'T' slots in it for fixing the workpiece or any vice/clamping arrangement used to hold the workpiece. The dimensions of the slots are shown in fig.5 in order to choose appropriate fixings. A 42 piece clamping kit is available as an optional extra. Part No. SM2502CK.
- 5.6. **Drilling guard.** When drilling ensure that the guard is in place (See fig.3-8).
- 5.7. **Speed control and ON/OFF operation.** Refer to Sections 4.9 to 4.14 for the operation of the main ON/OFF switch and speed setting.

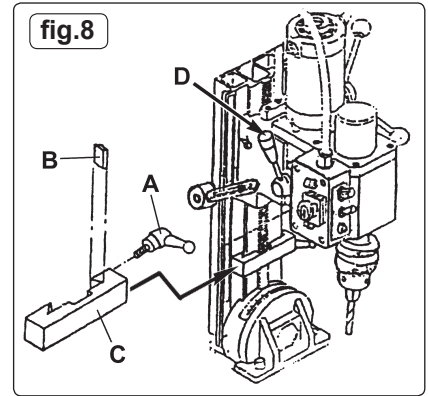

fig.8

6. MAINTENANCE

WARNING! Ensure the drilling/milling machine is unplugged from the mains power supply before attempting any maintenance.

- 6.1. Lubricate the machine before every use. See lubrication points on fig.10.
- 6.2. Clean the machine after each use.
- 6.3. Clean and coat the cross lead screw with oil weekly.
- 6.4. Lubricate the bearing, worm and worm shaft monthly.
- 6.5. Check that the table is horizontal periodically.
- 6.6. Adjust the accuracy of the cross feed, longitudinal feed and head travel on a monthly basis. Any wear or slack can be taken up by adjusting the position of the appropriate mitre strip. To do this use a hex key and spanner as shown in fig.8. Adjust the longitudinal feed using the adjusters marked 'L' in fig.7. Loosen the locking nuts on all four adjusters and back them off. Advance the adjusters until they are felt to make firm contact with the mitre wedge, ensuring that they are all tightened to the same torque. Operate the feed wheel to check the movement of the bed but do not force the movement. Back off the adjusters by an eighth of a turn and tighten the locknuts. Check that the table movement is smooth. If the movement is still tight, back the adjusters off a further eighth turn and tighten the adjuster nuts.
 - 6.6.1. Adjust the cross feed using the two adjusters marked 'C' in fig.7.
 - 6.6.2. Adjust the head movement using the four adjusters marked 'H' in fig.9
 - 6.6.3. Check that the column is vertical and that the column pivot nut is tight.

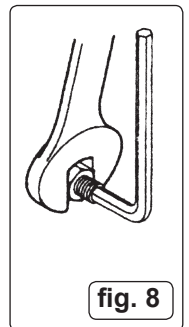

fig. 8

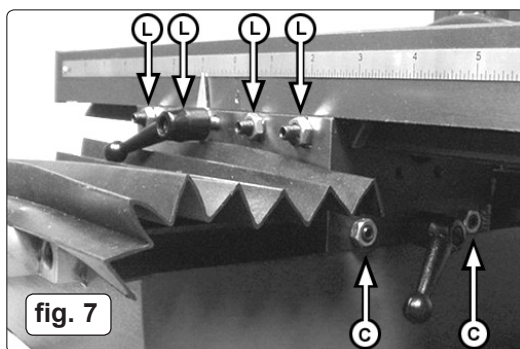

fig. 7

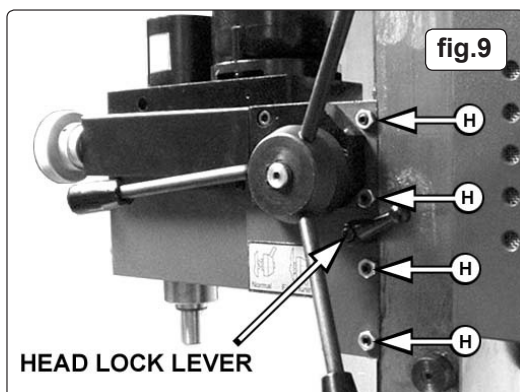

fig.9

HEAD LOCK LEVER

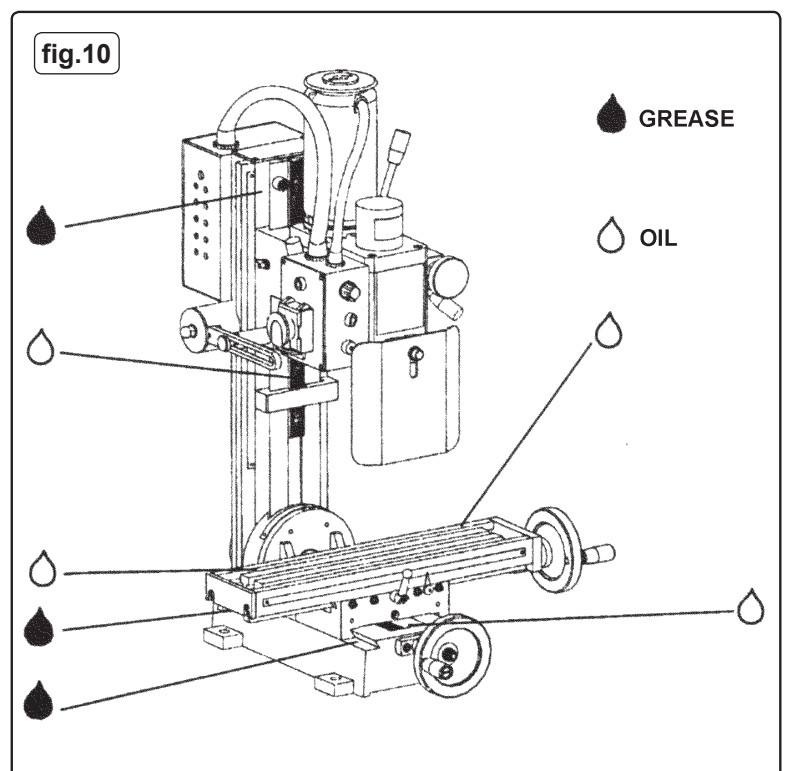

fig.10

GREASE

OIL

7. TROUBLESHOOTING

SYMPTOM	POSSIBLE CAUSE	CORRECTIVE ACTION
Motor overheats / no power	Feed is too fast. Faulty switch or motor. Overload protection has operated.	Decrease feed speed. Replace faulty part. (See parts list). Return speed switch to 'I' position and restart (See sec.4.10)
Spindle bearing getting hot.	No lubrication. Spindle bearing too tight.	Apply grease. Loosen the bearing.
Unbalanced table travel.	Excessive play in table movement. Cut depth too deep for cutting tool.	Adjust the mitre strips. (Refer to section 6.6). Decrease the depth of the cut.
Spindle shakes during use.	Spindle bearing gap is too wide. The chuck is loose. Cutter is blunt. Workpiece is loose.	Reduce the gap or replace the bearing. Re-seat the chuck in the arbor. Sharpen or replace the cutter. Secure the workpiece.
Vertical fine feed not functioning.	Clutch is loose. Worm and worm shaft are worn. Hand wheel fixing is loose. Drill feed still engaged.	Tighten the clutch. Replace worn parts. (See parts list). Realign and tighten fixing. Push drill feed hub inwards (See section 4.1)

8. OPTIONAL ACCESSORIES

42 PIECE CLAMPING KIT

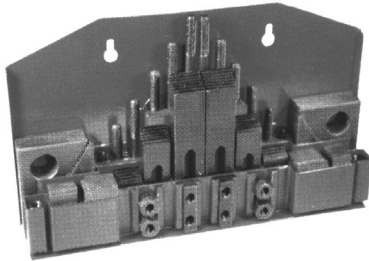

Part No. SM2502CK

QUICK VICE (WIDTH 100MM)

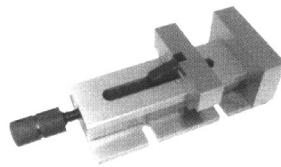

Part No. SM2502QV

INDEXABLE CARBIDE END MILL (MT3)

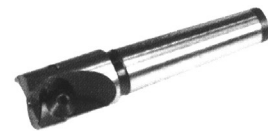

Part No. SM2502ICEM

MILL CHUCK SET (MT3) CHUCK DIAMETERS 4,6,8,10,12,14,16MM

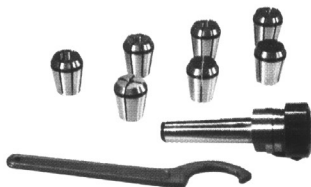

Part No. SM2502MCS

2 FLUTE HSS END MILL (SINGLES AND SET)



SM2502EM04 (DIAM 4MM)
SM2502EM06 (DIAM 6MM)
SM2502EM08 (DIAM 8MM)
SM2502EM10 (DIAM 10MM)
SM2502EM12 (DIAM 12MM)
SM2502EM14 (DIAM 14MM)
SM2502EM16 (DIAM 16MM)
SM2502EMSET (4 TO 16MM)

COLLET (MT3) (SINGLES AND SET)



SM2502C04 (DIAM 4MM)
SM2502C06 (DIAM 6MM)
SM2502C08 (DIAM 8MM)
SM2502C10 (DIAM 10MM)
SM2502C12 (DIAM 12MM)
SM2502C14 (DIAM 14MM)
SM2502C16 (DIAM 16MM)
SM2502CSET (4 TO 16MM)

ENVIRONMENT PROTECTION



Recycle unwanted materials instead of disposing of them as waste. All tools, accessories and packaging should be sorted, taken to a recycling centre and disposed of in a manner which is compatible with the environment. When the product becomes completely unserviceable and requires disposal, drain any fluids (if applicable) into approved containers and dispose of the product and fluids according to local regulations.



WEEE REGULATIONS

Dispose of this product at the end of its working life in compliance with the EU Directive on Waste Electrical and Electronic Equipment (WEEE). When the product is no longer required, it must be disposed of in an environmentally protective way. Contact your local solid waste authority for recycling information.

Note: It is our policy to continually improve products and as such we reserve the right to alter data, specifications and component parts without prior notice.

Important: No Liability is accepted for incorrect use of this product.

Warranty: Guarantee is 12 months from purchase date, proof of which is required for any claim.

Sealey Group, Kempson Way, Suffolk Business Park, Bury St Edmunds, Suffolk. IP32 7AR



01284 757500



01284 703534



sales@sealey.co.uk



www.sealey.co.uk