

Thank you for purchasing a Sealey product. Manufactured to a high standard this product will, if used according to these instructions and properly maintained, give you years of trouble free performance.

IMPORTANT: PLEASE READ THESE INSTRUCTIONS CAREFULLY. NOTE THE SAFE OPERATIONAL REQUIREMENTS, WARNINGS AND CAUTIONS. USE THIS PRODUCT CORRECTLY AND WITH CARE FOR THE PURPOSE FOR WHICH IT IS INTENDED. FAILURE TO DO SO MAY CAUSE DAMAGE OR PERSONAL INJURY, AND WILL INVALIDATE THE WARRANTY. PLEASE KEEP INSTRUCTIONS SAFE FOR FUTURE USE.

1. SAFETY INSTRUCTIONS

- ❑ **WARNING! Ensure health & safety, local authority, and general workshop practice regulations are adhered to when using this equipment.**
- ❑ **WARNING! Disconnect the washer from the air supply before changing accessories, servicing or performing any maintenance.** Maintain the washer in good condition (use an authorised service agent). Replace or repair damaged parts. Use genuine parts only. Non authorised parts may be dangerous and will invalidate the warranty. Locate the washer in an adequate working area for its function, Ensure the washer is stood on a firm level surface. Keep area clean and tidy and free from unrelated materials. Ensure the area is well ventilated and has adequate lighting.
- ❑ **WARNING! Installation site must be equipped with suitable fire extinguishers (water must not be used) and escape routes.**
- ❑ **WARNING! Ensure correct air pressure is maintained and not exceeded. Recommended pressure 75-100psi.** Keep air hose away from heat, oil and sharp edges. Check air hose for wear before each use, and ensure that all connections are secure. Use only recommended solvents as a cleaning agent, do not pour any other type of cleaning fluid into the tank. Keep the washer clean. Remove and clean the filter regularly for best and safest performance. Keep sources of ignition, such as heaters, lamps, etc away from the unit, together with flammable or combustible materials.
- ❑ **WARNING! Wear approved safety eye protection, mask and gloves. If fluid gets on skin or in eyes wash thoroughly with water and take any other action as required by the solvent instructions.** Remove ill fitting clothing, ties, watches, rings, and other loose jewellery, and contain long hair, and wear appropriate protective clothing. Maintain correct balance and footing. Ensure the floor is not slippery and wear non slip shoes. Keep non essential persons away from the working area. In case of fire in parts unit, do not attempt to remove parts, or the washer.
- ❑ **WARNING! DO NOT smoke whilst handling gunwash or solvents - risk of explosion.** DO NOT use the cleaner without the fume extraction flue attached, and ensure the flue removes the fumes appropriately. DO NOT use the washer for any purpose other than for which it is designed. DO NOT operate the washer if any parts are missing or damaged as this may cause failure or possible personal injury. DO NOT over fill the washer, and DO NOT use the washer without the cloth filter in base of unit. DO NOT direct air from the air hose at yourself or others. DO NOT operate the washer when you are tired, under the influence of alcohol, drugs or intoxicating medication. When cleaning is complete, ensure all controls are in the 'off' position and that the air supply is turned off.
- ❑ **WARNING! It is the user's responsibility to ensure that there is no uncontrolled discharge of any fluids used with this unit and that appropriate arrangements have been made for correct disposal of waste fluids in accordance with government and local authority regulations.**

2. INTRODUCTION & SPECIFICATIONS

The SM2499 is a compact unit suitable for busy medium sized body shop use. The tank is robustly manufactured, and features an air extraction, stainless steel wash tank with brass distribution bars. A self reciprocating pump delivers up to 12 ltrs / min with an air input pressure of 75-100psi and consumes approx 4/7cfm. This ensures a high volume of solvent is delivered through the spray jet nozzles and optimise the cleaning performance. The unit offers timed automatic enclosed wash, and manual wash and rinse feature, and is suitable for cleaning gravity, suction and HVLP guns.

SPECIFICATIONS

Operating pressure75-90psi
 Air Consumption4/7cfm
 Cleans2 pots + 2 guns
 Width/Depth/height (mm)710x350x1020
 Weight47kg

3. AIR SUPPLY

- 3.1. Ensure the air valve is in the "off" position before connecting to the air supply.
- 3.2. You will require an air pressure of more than 75psi , and an air volume of more than 4 cfm for operating the unit.
- 3.3. ❑ **WARNING! Ensure air supply does not exceed 100PSI. Too high an air pressure and unclean air will shorten the product life due to excessive wear, and may be dangerous causing possible damage and personal injury.**
- 3.4. Drain the air supply tank daily. Water in the air line will damage the item being supplied.
- 3.5. Clean the air inlet filter screen weekly. For recommended hook-up, see diagram to right.
- 3.6. Line pressure should be increased to compensate for unusually long air hoses (over 8 metres). The minimum hose diameter should be 10mm I.D. and fittings must have the same inside dimensions.
- 3.7. Keep hose away from heat, oil and sharp edges. Check hoses for wear, and make certain that all connections are secure.
- 3.8. The cleaner's input connection is 1/4" BSP.

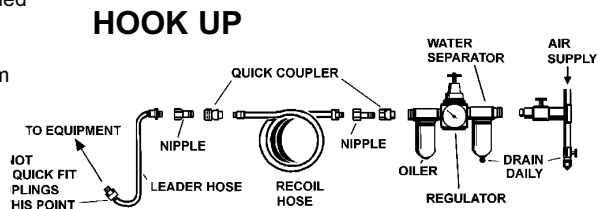

4. INSTALLATION

Unpack the product and check there are no damaged or missing parts. If there is a problem contact your supplier immediately.

4.1. INSTALLING THE MACHINE.

- 4.1.1. Position unit in a well ventilated area on a solid level floor with good access to a suitable air supply. Consider the handling and storage of waste fluids.
- 4.1.2. Connect air supply to the inlet on the right hand side of control unit (fig 1).
- 4.1.3. Fit a 3" (75mm) flue over the cleaners air extraction outlet (fig 1.2). Ensure the first 1m of flue is vertical and thereafter the flue may curve to the designated ventilation outlet which should remove fumes to the outside of the building.
A range of adaptors are available from your Sealey dealer (fig 2)
- 4.1.4. Place the work screen and green filter (10) in the bottom of tank (1).
The cleaning tank is now ready for use.

4.2. CONNECTING THE SOLVENT SUPPLY.

- WARNING! Wear safety eye protection, mask and gloves. If fluid gets on skin or in eyes wash thoroughly with water and take any action as required by solvent instructions.**
- 4.2.1. Drain of 5ltrs from a new 25ltr solvent drum (3) into a suitable container (4) to be used as a 'clean rinse' supply.
 - 4.2.2. Push the extraction filter (5) to the bottom of the 25ltr drum.
 - 4.2.3. Place the outlet drain hose (6) also into the top of the solvent drum. If necessary, disconnect hose quick release coupling to allow insertion of the extraction hose. To do so, lift the locking ring (fig 1. A) and once inserted into the solvent drum re-connect the hose.
 - 4.2.4. Push both solvent containers under the cleaning unit with the 5ltr container to the right hand side. Height of unit may be increased by adjusting legs (8).
 - 4.2.5. Place the brass 'clean rinse' pick up pipe (7) into 5ltr container and close the front panel (9).

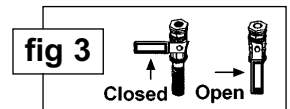
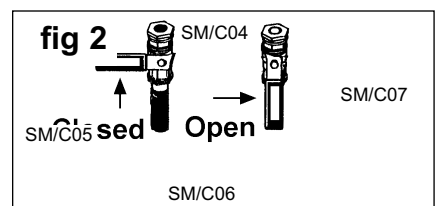
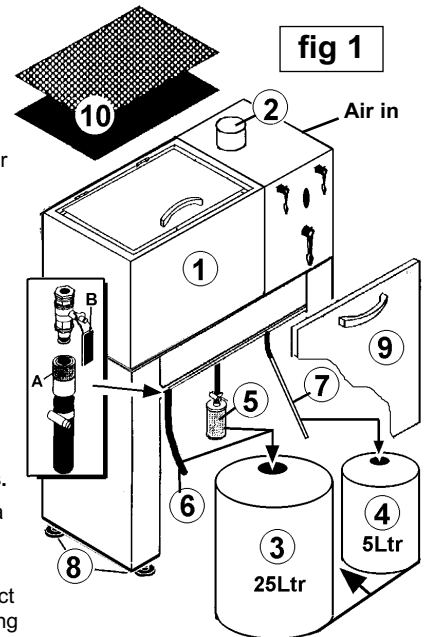

5. OPERATING INSTRUCTIONS

- WARNING! Wear approved safety eye protection, mask and gloves. If fluid gets on skin or in eyes wash thoroughly with water and take any other action as required by the solvent instructions.**

5.1. PREPARING TANK & ITEMS FOR CLEANING.

- 5.1.1. Turn air supply on, and open drainer tap (fig 3, & fig 1.B) by rotating to the vertical position.
- 5.1.2. Check the spray gun to be cleaned, empty and store any excess paint for future use. For best result, remove as much residual paint as possible. Loosen dirt and remove stubborn paint residue with aid of a brush (not included). Clean spray gun immediately after use.

5.2. PRE WASH (MANUAL CLEAN).

- WARNING! Wear approved safety eye protection, mask and gloves. If fluid gets on skin or in eyes wash thoroughly with water and take any other action as required by the solvent instructions.**

- 5.2.1. Open lid. The fume extraction system will start automatically.
- 5.2.2. Turn the selection lever (fig 4.1) to MANUAL.
- 5.2.3. Turn MANUAL WASH lever (fig 4.3) to 'ON', solvent will circulate through wash/rinse head (fig 5.1) from the 25 litre 'dirty' solvent drum. Wash spray items accordingly.

5.3. AUTOMATIC CLEAN.

- 5.3.1. Place paint cup/pot into cleaning tank and over the top of a pair of square nozzle jets.
- 5.3.2. The spray gun air cap may be loosened or removed completely and put into the tank.
- 5.3.3. To open the spray gun for cleaning, fit trigger clip (fig 6.A).
- 5.3.4. Place the spray gun into the tank over cleaning nozzle as follows:
 - a) If suction gun, fit directly onto taper nozzle (fig 7.A).
 - b) If gun is a gravity or pressure type use nozzle extensions (fig 7 B & C).
- 5.3.5. Close the lid. You are now ready to commence the cleaning operation.
- 5.3.6. Turn the selection lever (fig 4.1) to AUTOMATIC.
- 5.3.7. Turn the TIMER (fig 4.2) clockwise to its maximum setting (approx 45 seconds) to start cleaning. The unit's air system will draw solvent through the filter in the bottom of the 25ltr drum and expel an atomised spray through the recirculated solvent manifold nozzles in the cleaning tank. Solvent will drain through the outlet hose in the bottom of the tank back into the 25ltr drum.
- 5.3.8. When the timer stops the lid may be opened and clean spray equipment removed.

NOTE: If, during cleaning, the lid is opened, a microswitch will automatically halt the cleaning process and the fumes will be extracted through the unit's extraction flue (fig1. 2). Close lid for cleaning to continue. DO NOT store guns in tank.

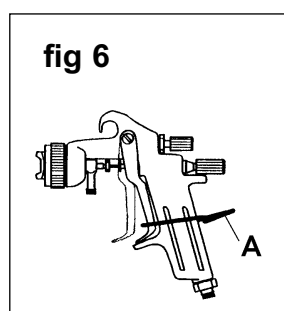
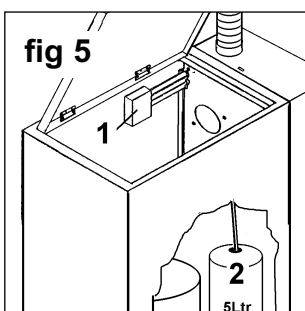
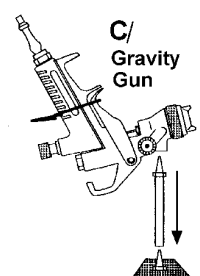
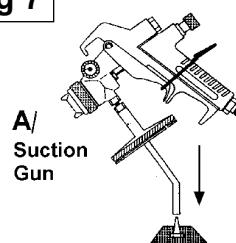

fig 7



5.4. CLEAN RINSE 'MANUAL'

- WARNING! Wear approved safety eye protection, mask and gloves. If fluid gets on skin or in eyes wash thoroughly with water and take any action as required by solvent instructions.**
To rinse any items that have been washed automatically or manually, proceed as follows:

- 5.4.1. Turn selection lever (fig 8.1). to MANUAL.
- 5.4.2. Open lid and the fume extraction system will start automatically .
- 5.4.3. Turn the CLEAN RINSE lever to ON (fig 8.4).
Clean solvent will be drawn from the 'CLEAN' 5 litre container (fig 5.2), and ejected through the 'wash/rinse' head (fig 5.1). The used solvent will drain into the 25ltr tank.
- 5.4.4. Rinse spray items accordingly.

NOTE: Ensure that the solvent in the 5ltr 'clean rinse' container is clean. DO NOT top up with used solvent.

5.5. WHEN CLEANING IS COMPLETE.

Remove all items from the cleaning tank and store accordingly. DO NOT store guns in tank.
Turn the air supply off, close the tank lid, wipe up any spillage, and wipe any soil marks from the unit.

- WARNING! It is operators responsibility to ensure that there is no uncontrolled discharge of any fluids used with this unit and that appropriate arrangements have been made for correct disposal of waste in accordance with government/local authority regulations.**

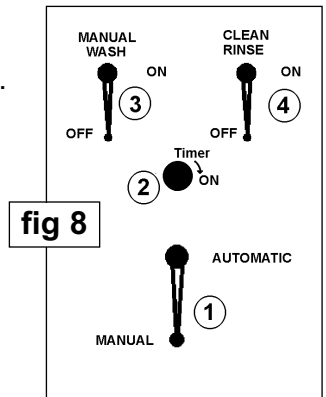

6. SOLVENT CHANGE & MAINTENANCE

- WARNING! It is operators responsibility to ensure that there is no uncontrolled discharge of any fluids used with this unit and that appropriate arrangements have been made for correct disposal of waste in accordance with government/local authority regulations.**
- WARNING! Disconnect the washer from the air supply before changing accessories, servicing or performing any maintenance.**
- WARNING! Wear approved safety eye protection, mask and gloves. If fluid gets on skin or in eyes wash thoroughly with water and take any other action as required by the solvent instructions.**

6.1 TO CHANGE SOLVENT

The amount of guns a 25 litre drum of solvent can clean will depend upon the amount of residue paint which is left in spray equipment. We recommend however that the solvent is changed on a regular basis to provide optimum machine performance.

- 6.1.1. Close the drain tap, and remove drain hose and filter from drum. Store the used solvent in accordance with regulations.
- 6.1.2. Clean the filter before reuse.
- 6.1.3. Insert the filter and hose into a new solvent drum as in section 4.
- 6.1.4. The clean wash container may of course be re-used. Check to ensure it is clean and top up with 5ltrs from new 25ltr drum.
Wipe up any spillage immediately.

6.2. MAINTENANCE.

- 6.2.1. Clean the inside of the tank just before changing the solvent. To do so, close the drain tap (fig 3), start the machine and allow a quantity of fluid to enter the tank. Turn machine off, lift lid and use the fluid to clean out the inside of the tank, removing any residue waste. Open the drain valve to empty the tank.
- 6.2.2. Keep pick-up filter clean by rinsing in solvent and blowing out with an air line.
- 6.2.3. Change the green base filter (order model no SM2499/16) every three months, or more frequent if heavy use.
- 6.2.4. Regularly check to ensure there are no obstructions to the extraction flue.
- 6.2.5. Periodically check for correct operation of lid 'cut-off' device and air extraction.
- 6.2.6. Regularly inspect the air hoses and fittings to ensure their integrity.
- 6.2.7. Keep the outside of the unit clean.

SPRAY GUN CLEANING TANK MODEL SM2499

93/68/EEC CE Marking Directive
89/336/EEC Directive (S.I. 1992/2372) & Amendments
98/37/EEC Machinery Directive (S.I 1992/3073)

Declaration of Conformity We, the sole importer into the UK, declare that the product listed here is in conformity with the following EEC standards and directives



Signed by Mark Sweetman

1st August 1999

The construction file for this product is held by the Manufacturer and may be inspected on request by contacting Jack Sealey Ltd

For Jack Sealey Ltd. Sole importer into the UK of Sealey Power Products

NOTE: It is our policy to continually improve products and as such we reserve the right to alter data, specifications and component parts without prior notice.

IMPORTANT: No liability is accepted for incorrect use of this product. **WARRANTY:** Guarantee is 12 months from purchase date, proof of which will be required for any claim. **INFORMATION:** Call on 01284 757525 for a copy of our catalogue. Leave your full name, address & postcode.



Sole UK Distributor,
Sealey Group, Bury St. Edmunds, Suffolk.



01284 757500



01284 703534

E-mail: sales@sealey.co.uk