

Thank you for purchasing a Sealey quality product. Manufactured to a high standard this product will, if used according to these instructions and properly maintained, give you years of trouble free performance.



IMPORTANT BEFORE USING THIS PRODUCT, PLEASE READ THE INSTRUCTIONS CAREFULLY. MAKE CAREFUL NOTE OF SAFETY INSTRUCTIONS, WARNINGS AND CAUTIONS. THIS PRODUCT SHOULD ONLY BE USED FOR ITS INTENDED PURPOSE. FAILURE TO DO SO MAY CAUSE DAMAGE AND/OR PERSONAL INJURY AND WILL INVALIDATE THE WARRANTY. KEEP THESE INSTRUCTIONS SAFE.

1. SAFETY INSTRUCTIONS

1.1. ELECTRICAL SAFETY

WARNING! It is the responsibility of the owner and the operator to read, understand and comply with the following:

You must check all electrical products, before use, to ensure that they are safe. You must inspect power cables, plugs, sockets and any other connectors for wear or damage. You must ensure that the risk of electric shock is minimised by the installation of appropriate safety devices. A Residual Current Circuit Breaker (RCCB) should be incorporated in the main distribution board. We also recommend that a Residual Current Device (RCD) is used. It is particularly important to use an RCD with portable products that are plugged into a supply which is not protected by an RCCB. If in any doubt consult a qualified electrician. You may obtain a Residual Current Device by contacting your Sealey dealer.

You must also read and understand the following instructions concerning electrical safety.

1.1.1. The **Electricity at Work Act 1989** requires all portable electrical appliances, if used on business premises, to be tested by a qualified electrician, using a Portable Appliance Tester (PAT), at least once a year.

1.1.2. The **Health & Safety at Work Act 1974** makes owners of electrical appliances responsible for the safe condition of those appliances and the safety of the appliance operators. **If in any doubt about electrical safety, contact a qualified electrician.**

1.1.3. Ensure that the insulation on all cables and on the appliance is safe before connecting it to the power supply. See 1.1.1. and 1.1.2. and use a Portable Appliance Tester.

1.1.4. Ensure that cables are always protected against short circuit and overload.

1.1.5. Regularly inspect power supply cables and plugs for wear or damage and check all connections to ensure that none is loose.

1.1.6. **Important:** Ensure that the voltage marked on the appliance matches the power supply to be used and that the plug is fitted with the correct fuse - see fuse rating at right.

1.1.7. **DO NOT** pull or carry the appliance by the power cable.

1.1.8. **DO NOT** pull the plug from the socket by the cable.

1.1.9. **DO NOT** use worn or damaged cables, plugs or connectors. Immediately have any faulty item repaired or replaced by a qualified electrician. When an ASTA/BS approved UK 3 pin plug is damaged, cut the cable just above the plug and **dispose of the plug safely.** Fit a new plug according to the following instructions (UK only).

a) Connect the **GREEN/YELLOW** earth wire to the earth terminal 'E'.

b) Connect the **BROWN** live wire to the live terminal 'L'.

c) Connect the **BLUE** neutral wire to the neutral terminal 'N'.

d) **After wiring, check that there are no bare wires, that all wires have been correctly connected, that the cable outer insulation extends beyond the cable restraint and that the restraint is tight.**

Double insulated products, which are always marked with this symbol , are fitted with live (brown) and neutral (blue) wires only. To rewire, connect the wires as indicated above - **DO NOT** connect either wire to the earth terminal.

1.1.10. Products which require more than 13 amps are supplied without a plug. In this case you must contact a qualified electrician to ensure that a suitably rated supply is available. We recommend that you discuss the installation of an industrial round pin plug and socket with your electrician.

1.1.11. If an extension reel is used it should be fully unwound before connection. A reel with an RCD fitted is preferred since any appliance plugged into it will be protected. The cable core section is important and should be at least 1.5mm², but to be absolutely sure that the capacity of the reel is suitable for this product and for others which may be used in the other output sockets, we recommend the use of 2.5mm² section cable. If extension reel is to be used outdoors, ensure it is marked for outdoor use.

1.2. GENERAL SAFETY

WARNING! Disconnect the hacksaw from the power source before servicing, changing accessories or performing any other maintenance.

✓ Familiarise yourself with applications and limitations of the product, as well as the potential hazards.

✓ Maintain the hacksaw in top condition. Keep it clean and keep blades sharp for best and safest performance.

✓ Use original Sealey spare parts only. Unauthorised parts may be dangerous and will invalidate the warranty.

✓ Keep all guards and fixing screws in place, tight and in working order. Check regularly for damaged parts. A guard or any other part that is damaged should be repaired or replaced before the saw is used further. Check also for proper alignment of moving parts, loose mountings, or any other condition that could affect the operation of the saw.

✓ Ensure the space allocated for use and maintenance of the machine is adequate, free from unrelated materials and has good lighting.

✓ Remove any adjusting keys and wrenches from the machine before operating.

✓ Wear approved eye and ear protection when operating the machine. If dust is produced, wear an approved face or dust mask.

✓ Keep correct footing and balance at all times.

✓ Always secure the workpiece in the vice.

✓ Keep children and unauthorised persons away from the working area, especially when the saw is in operation.

✓ Ensure that large or oversize workpieces are supported at hacksaw table height. Ensure you use a suitable support for any workpiece that does not have a flat surface. Be cautious when cutting workpieces which are irregular in cross-section. The saw blade could be pinched before the cut is completed. Any stock such as frame moulding, must lay flat on the table surface and not be allowed to rock.

WARNING! Rods and tubing have a tendency to roll while being cut and cause the blade to "bite". **DO NOT** cut such items without clamping or blocking the workpiece.

WARNING! Never force the blade through the workpiece.

X **DO NOT** use this machine for anything other than its intended purpose. The machine is designed for light metal cutting work in engineering workshops, garages, metal fabricators, etc.

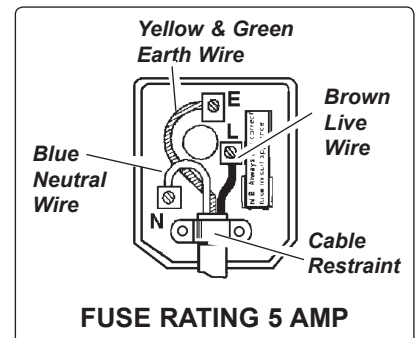

- ❑ **WARNING!** These hacksaws **MUST NOT** be used to cut **non-metallic materials** (including wood) as to do so will invalidate your insurance cover and your warranty and may cause damage and/or personal injury.
- ✗ DO NOT wear loose or ill-fitting clothing. Remove ties, watches, rings and other jewellery. Tie up, or adequately cover, long hair.
- ✗ DO NOT start machine until workpiece is secure and the blade has been lowered to just above the workpiece.
- ✗ DO NOT use the hacksaw with the blade guard or pulley cover removed.
- ✗ DO NOT use damaged or deformed hacksaw blades.
- ✓ Turn the saw off **before** raising the blade.
- ✗ DO NOT run the saw with the blade in the raised position.
- ✗ DO NOT use the machine in wet or damp locations.
- ✗ DO NOT use the machine in areas where fumes from paint, solvents, or flammable liquids pose a potential hazard. Keep all flammable materials (including wipers or cleaning rags) away from the saw, and dispose of according to local regulations.
- ✗ DO NOT stand on the machine.
- ✗ DO NOT leave machine running unattended. Turn power switch 'Off' and do not leave area until machine has come to a complete stop.
- ✗ DO NOT operate the saw when you are tired, under the influence of alcohol, drugs or intoxicating medication.

2. INTRODUCTION & SPECIFICATIONS

2.1. Introduction.

The SM16/1, SM17/1 and SM18/1 power hacksaws are manufactured to comply with Supply of Machinery (Safety) Regulations 1992 (S.I.3073). Cast base with integral mitring vice and setting bar for repetition cutting. Machined saw arm runners with wear shims for smooth cutting performance. Automatic power cut-off stops machine after completion of cutting. Fitted with heavy duty 230Volt single phase electric motor and an approved 3 pin safety plug. SM17/1 and SM18/1 supplied with a belt driven coolant pump system to lubricate and cool the workpiece. Fully guarded pulley and drive assembly.



2.2. Specifications

Model No	SM16/1	SM17/1	SM18/1
Capacity at 90° (mm)	180 X 180	185 X 185	196 X 205
Capacity at 45° (mm)	90 X 180	90 X 185	110 X 205
Motor	375W 230V	375W 230V	375W 230V
Size of blade	400 X 25 X 1.25mm	400 X 25 X 1.25mm	400 X 32 X 1.6mm
Cutting speed	50/70 strokes/min	50/70 strokes/min	60/80 strokes/min
Working floor area required	1020 X 350mm	1020 X 350mm	1050 X 370mm
Weight	110kg	115kg	140kg

3. ASSEMBLY AND SET UP CHECKS

Note: Letters in brackets refer to Fig.1.

3.1. Glass oiler

- 3.1.1. The glass oiler ensures constant lubrication between the bow saw and the saw arm.
- 3.1.2. Screw the glass oiler into the mounting on the saw bow, as shown in (A).
- 3.1.3. Fill the oiler with light machine oil.
- 3.1.4. Adjust the rate of flow by turning the serrated collar on the top of the oiler.

3.2. Oil caps

- 3.2.1. There are five oil caps fitted to the saw, (B1 - B5).
- 3.2.2. Remove the six self tapping screws in the guard, (C, only two shown) and fold it down.
- 3.2.3. Identify the two oil caps on the frame support (B1 & B2) and the two on the saw arm, (B3 & B4).
- 3.2.4. Lift each cap in turn and fill the cups with light machine oil. Allow time for the oil to penetrate and refill as necessary.
- 3.2.5. Fold the guard into position and refit the six screws removed in paragraph 3.2.2.
- 3.2.6. The fifth oil cap is fitted on the connecting rod, (B5). Lift the cap and fill the cup with light machine oil.

3.3. Length bar

- 3.3.1. When cutting multiple same length pieces, the length bar and length plate can be fitted to save the operator having to measure the item to be cut each time.
- 3.3.2. Screw the length bar (D) into the side of the saw bed and tighten the locking nut.
- 3.3.3. Adjust the length plate (E) to the required position and lock in place by tightening the "T" head bolt (F).

3.4. Blade tension

- 3.4.1. Check the blade tension by flicking the blade. The blade should make a sharp pining sound if it is properly adjusted.
- 3.4.2. If the blade needs adjusting, refer to paragraph 5.3.

3.5. Coolant tank (Models SM17/1 and SM18/1 only)

- 3.5.1. Fill the cooling tank, attached to the underside of the saw bed, with cutting oil by pouring through the slots in the saw bed into the coolant tank. Ensure the supply tap at the base of the coolant pipe is turned off.

Note: Neat cutting oil, part no NCO/5L and soluble cutting oil SCO/5L are available from your local Sealey dealer.

3.6. Saw arm weight

- 3.6.1. Fit the saw arm weight, (G) onto the saw arm to increase the cutting weight if required.

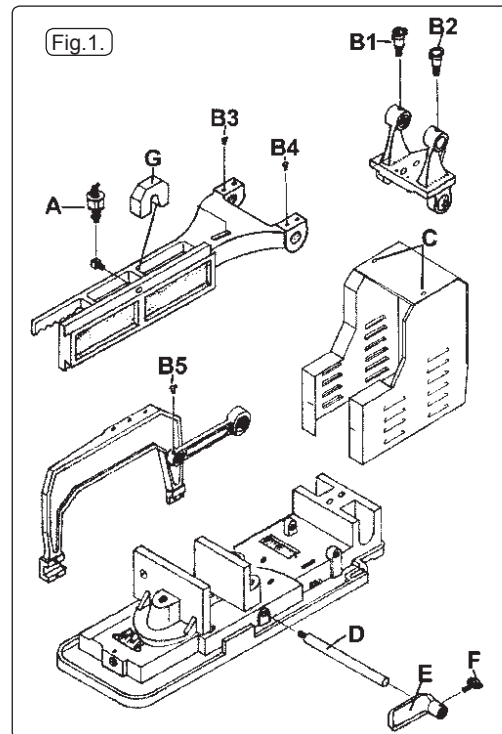

4. OPERATION

❑ **WARNING! Before operating the hacksaw ensure that you read, understand and apply the safety instructions in Section 1. NOTE: Before operating the machine certain checks and adjustments will need to be carried out. It is very important that these instructions are followed carefully in order that the machine is set up safely and correctly.**

❑ **WARNING! The machine is designed for the cutting of light metal in engineering workshops, garages, metal fabricators, etc. The SM16/1, SM17/1 & SM18/1 must not be used to cut any other materials (including wood). To do so will invalidate your insurance cover and your warranty and may cause damage and/or personal injury.**

❑ **WARNING! Ensure that the saw is disconnected from the power supply before making any adjustments.**

4.1. Set up checks

4.1.1. Check the saw thoroughly before using it. Ensure the guards are correctly fitted and that the moving parts are secure and in working order.

4.1.2. Raise the saw arm as far as possible.

4.1.3. Place the work piece in the vice, set the length bar as required and clamp the work piece securely. For angled cutting, see 4.2.

4.1.4. If cutting mild steel, turn on the coolant supply tap (models SM17/1 and SM18/1 only) and direct the coolant nozzle towards the area of the workpiece that will be cut.

Note: Ensure the oiler is correctly set and that oil has been applied to the five oil caps before starting the saw.

4.1.4. Connect the machine to the mains power supply.

4.1.5. Start the machine and the arm will automatically lower and start cutting.

4.1.6. When sawing is completed the saw will switch off automatically, disconnect from the power supply, raise blade and remove workpiece.

Never raise blade when machine is running .

4.2. Vice setting

4.2.1. The vice is locked at 0° but can be set to any angle up to 45°.

4.2.2. To set an angle on the vice, remove the centre bolt fig.2.C and vice clamp bolt fig.2.D.

4.2.3. Loosen the vice swivel bolt fig.2.A and the vice clamp bolt fig.2.B.

4.2.4. Set the vice to the required angle and tighten vice swivel bolt fig.2.A and the vice clamp bolt fig.2.B.

4.2.5. Loosen the free vice clamp bolt fig.2.E.

4.2.6. Place the work piece in the vice and wind the free vice closed until it grips the workpiece.

4.2.7. Tighten the free vice clamp bolt fig.2.E and ensure the workpiece is securely clamped.

4.2.8. Where the length of the workpiece to be secured is half the width of the vice, or less, adjust the bolt on the free vice so that it touches the fixed vice face, as shown in fig.3.

4.2.9. The saw bed provides an alternative pair of mounting holes for the fixed side of the vice. To use these holes, remove the centre bolt fig.2.C, the vice clamp bolts fig.2.B & D and the vice swivel bolt fig.2.A.

4.2.10. Position the fixed side of the vice on the saw bed such that the vice swivel bolt fig.2.A is located through the vice and into the mounting hole fig.2.F.

4.2.11. Fit one of the vice clamp bolts fig.2.B or D through the vice and into mounting hole fig.2.G.

Note: When using these alternative mounting holes, the fixed vice does not have a 0° lock facility. It is the responsibility of the operator to ensure that the fixed vice is at the correct angle.

4.2.12. Set the vice to the required angle and secure by tightening the vice swivel fig.2.A and clamp bolt fig.2.D.

Note: Use of these alternative mounting holes can lengthen the life of the saw blades.

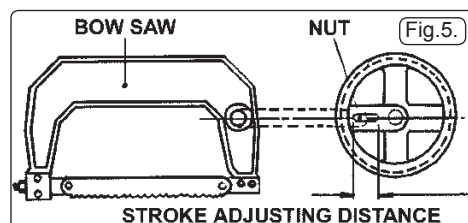
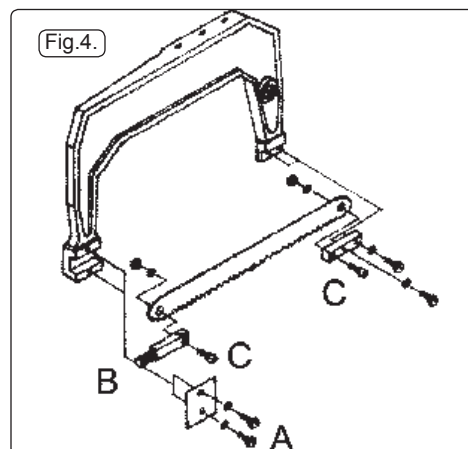
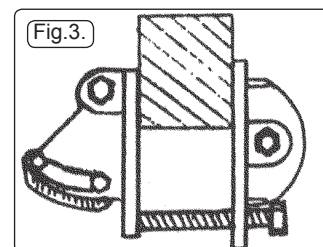
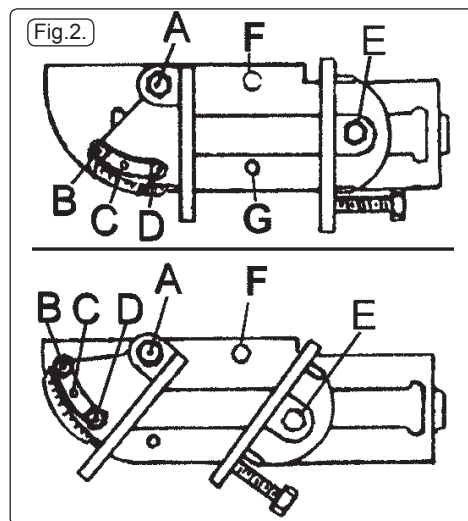

5. MAINTENANCE & ADJUSTMENTS

❑ **WARNING! BEFORE CARRYING OUT ANY MAINTENANCE OR MAKING ANY ADJUSTMENTS, DISCONNECT SAW FROM POWER SUPPLY.**

5.1. Cleaning

5.1.1. Clean saw after each operation and smear unpainted surfaces with oil to prevent rusting.

5.2. Replacing the saw blade

We recommend you keep a small supply of commonly used saw blades to hand. Change saw blades frequently for best results. Ensure you choose a blade with a pitch suitable for workpiece to be cut.

5.2.1. Disconnect the machine from the power supply.

5.2.2. Loosen the two screws, fig.4.A, holding the fixed plate on.

5.2.3. Undo the two locking nuts, fig.4.B and release the tension in the blade.

5.2.4. Undo the two blade retaining screws, fig.4.C and remove the blade.

5.2.5. Fitting the new blade is the reverse of the procedure in paragraphs 5.4.1. to 5.4.3.

5.2.6. Tension the blade as described in paragraph 5.5.

5.3. Blade tension

5.3.1. Test the blade tension by flicking the blade. The blade should make a sharp pinging sound if it is correctly adjusted.

5.3.2. To adjust the blade tension, turn the lock nuts fig.4.B. **Do not over tighten.**

5.4. Blade stroke adjustment

5.4.1. Disconnect the machine from the power supply.

5.4.2. The sawblade stroke can be adjusted ± 60 mm.

5.4.3. Remove the six self tapping screws in the guard, fig.1.C and fold it down.

5.4.4. Loosen the nut on the inside of the gear wheel, fig.5.

- 5.4.5. To shorten the stroke, slide the bow saw towards the centre of the gear wheel and to lengthen the stroke, slide the bow saw towards the outside of the gear wheel.
- 5.4.6. Tighten the nut on the inside of the gear wheel, fig.5.
- 5.4.7. When satisfied that the adjustment is accurate, carefully turn the pulley by hand to see if the blade snags or rubs at any point. Readjust stroke if necessary.
- 5.4.8. Fold the guard into position and refit the six screws removed in paragraph 5.4.3.

5.5. Hydraulic pump - oil change

- 5.5.1 The oil in the hydraulic pump should be changed every 6 months.
- 5.5.2 Remove the six self tapping screws in the guard, fig.1.C and fold it down.
- 5.5.3 Remove the cotter pin, fig.6.A and the compression arm retaining pin, fig.6.B.
- 5.5.4 Lift off the compression arm, fig.6. C.
- 5.5.5 Remove the cotter pin, fig.6. D and the swing bolt retaining pin, fig.6.E.
- 5.5.6 Loosen the two hydraulic pump retaining bolts, fig.6.F and lift out the hydraulic pump.
- 5.5.7 Undo the four screws in the hydraulic pump top plate (not shown), lift the plate off and empty the oil into a suitable container and dispose of according to local regulations.

- 5.5.8 Refill the pump with oil.

Note: Use a good quality jack oil, such as SEALEY HYDRAULIC JACK OIL.

- 5.5.9 Assembly and fitting instructions are the reverse of paragraphs 5.5.2. to 5.5.7. above.

5.6. Bow saw & saw arm adjustment

- 5.6.1 Play between the bow saw and the saw arm can be removed by adjusting the three tensioning bolts shown in fig.7.
- 5.6.2 Loosen the three lock nuts and tighten the tensioning bolts until the play has been removed.
- 5.6.3 Tighten the three lock nuts.

Note: Do not over tighten the tensioning bolts as this will cause excessive wear.

5.7. Vibration

- 5.7.1 If the saw arm shakes, vibrates excessively or appears otherwise insecure it may be necessary to tighten the support frame,fig.8 to the gear shaft or tighten the saw arm to the support frame fig.9.
- 5.7.2 To tighten the support, remove the six self tapping screws in the guard, fig.1.C and fold it down.
- 5.7.3 Loosen the lock nuts and tighten the bolts fig.8 such that any movement on the gear shaft is significantly reduced.
- 5.7.4 Tighten the lock nuts.
- 5.7.5 Fold the guard into position and refit the six screws removed in paragraph 5.7.2.

Note: Do not over tighten the bolts as this will cause excessive wear.

- 5.7.6 To tighten the support, remove the six self tapping screws in the guard, fig.1.C and fold it down.
- 5.7.7 Loosen the outer lock nut, fig.9, tighten the inner lock nut and tighten the outer lock nut.
- 5.7.8 Fold the guard into position and refit the six screws removed in paragraph 5.7.6.

5.7. Adjusting rate of decent of the saw arm

- 5.7.1 The rate of decent of the saw arm can be adjusted by altering the effective length of the compressing bracket.
- 5.7.2 Remove the six self tapping screws in the guard, fig.1.C and fold it down.
- 5.7.3 To increase the rate of decent of the saw arm, loosen lock nut "A", fig.10, and tighten lock nut "B", fig.10 shortening the effective length of the compressing bracket.
- 5.7.4 To decrease the rate of decent of the saw arm, loosen lock nut "B", fig.10 and tighten lock nut "A", fig.10 increasing the effective length of the compressing bracket.

- 5.7.5 Fold the guard into position and refit the six screws removed in paragraph 5.7.2.

Note: Fine adjustment of the rate of decent of the saw arm is possible using the fine adjuster, fig.11, on the hydraulic pump (SM18/1 only).

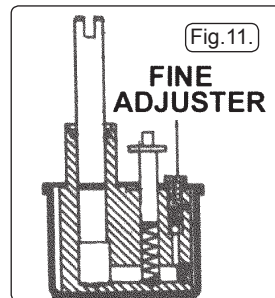
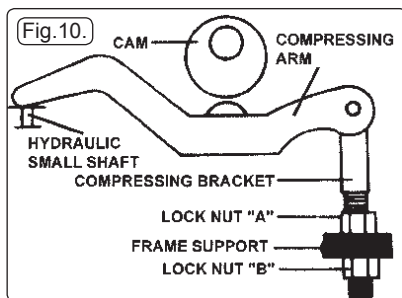
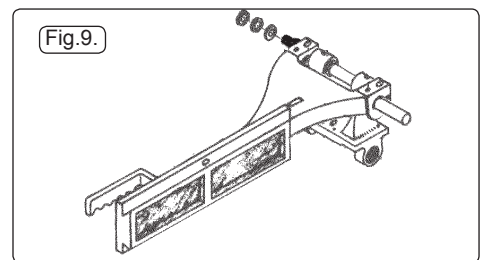
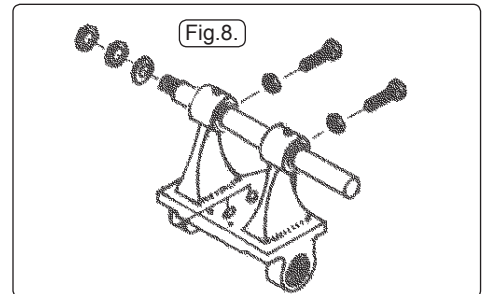
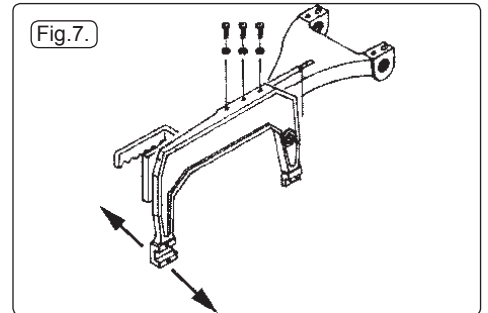
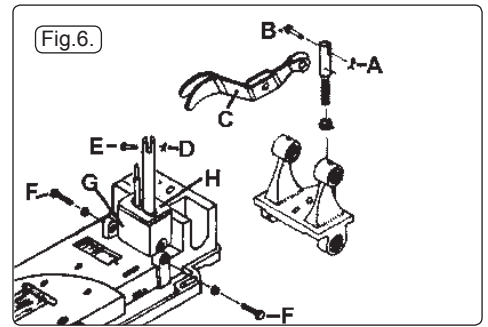

6. TROUBLESHOOTING

Problem	Possible Cause	Solution
The angle of the cut is inaccurate.	<ol style="list-style-type: none"> 1. The tensioning bolts on the bow are loose. 2. The blade is not tight. 3. The blade is dull. 4. The setting on the vice is inaccurate. 	<ol style="list-style-type: none"> 1. Tighten the bolts. 2. Tighten the blade. 3. Replace the blade. 4. Set the vice at 0 using a right angle and adjust the pointer to match.
No power	<ol style="list-style-type: none"> 1. Oil level is low. 2. The tensioning bolts are loose. 	<ol style="list-style-type: none"> 1. Check oil and fill up as required. 2. Tighten the bolts.
Saw is not cutting efficiently.	<ol style="list-style-type: none"> 1. Pressure from the saw arm is too light. 2. The stroke of the blade is incorrect. 3. Saw blade is the wrong type. 4. Saw blade is worn. 	<ol style="list-style-type: none"> 1. Attach a heavier weight to the arm. 2. Adjust the stroke. 3. Use a different TPI blade. 4. Replace the blade.
Saw blade does not rise when cutting.	<ol style="list-style-type: none"> 1. Hydraulic pressure is low. 2. Compressing arm is too low. 3. The cam is loose. 4. Air is in the hydraulic system. 	<ol style="list-style-type: none"> 1. Check the pressure. Refill if needed. 2. Adjust the compressing bracket to a higher position. 3. Tighten the cam. 4. Pump the arm a few times manually.
Excessive noise.	<ol style="list-style-type: none"> 1. The saw is low on lubricant. 2. The pulley is touching the pulley guard. 3. The gears are worn out. 4. Screws, bolts or other moving parts are loose. 	<ol style="list-style-type: none"> 1. Check lubricant and refill as required. 2. Adjust the pulley so that it does not touch the guard. 3. Replace the gears. 4. Tighten loose parts as required.
Coolant delivery is weak.	<ol style="list-style-type: none"> 1. Sediment may have collected in the cooling tank. 	<ol style="list-style-type: none"> 1. Clean the cooling tank .

NOTE: It is our policy to continually improve products and as such we reserve the right to alter data, specifications and component parts without prior notice.

IMPORTANT: No liability is accepted for incorrect use of this product.

WARRANTY: Guarantee is 12 months from purchase date, proof of which will be required for any claim.

INFORMATION: For a copy of our latest catalogue and promotions call us on 01284 757525 and leave your full name and address, including postcode.



Sole UK Distributor, Sealey Group,
Kempson Way, Suffolk Business Park,
Bury St. Edmunds, Suffolk,
IP32 7AR



01284 757500



www.sealey.co.uk



01284 703534



sales@sealey.co.uk