



INSTRUCTIONS FOR:
VARIABLE SPEED SCROLL SAW
MODEL No: **SM1302**

Thank you for purchasing a Sealey product. Manufactured to a high standard this product will, if used according to these instructions and properly maintained, give you years of trouble free performance.



IMPORTANT: PLEASE READ THESE INSTRUCTIONS CAREFULLY. NOTE THE SAFE OPERATIONAL REQUIREMENTS, WARNINGS & CAUTIONS. USE THE PRODUCT CORRECTLY AND WITH CARE FOR THE PURPOSE FOR WHICH IT IS INTENDED. FAILURE TO DO SO MAY CAUSE DAMAGE AND/OR PERSONAL INJURY AND WILL INVALIDATE THE WARRANTY. PLEASE KEEP INSTRUCTIONS SAFE FOR FUTURE USE.

1. SAFETY INSTRUCTIONS

1.1. ELECTRICAL SAFETY

WARNING! It is the responsibility of the owner and the operator to read, understand and comply with the following:

You must check all electrical products, before use, to ensure that they are safe. You must inspect power cables, plugs, sockets and any other connectors for wear or damage. You must ensure that the risk of electric shock is minimised by the installation of appropriate safety devices. A Residual Current Circuit Breaker (RCCB) should be incorporated in the main distribution board. We also recommend that a Residual Current Device (RCD) is used. It is particularly important to use an RCD with portable products that are plugged into a supply which is not protected by an RCCB. If in any doubt consult a qualified electrician. You may obtain a Residual Current Device by contacting your Sealey dealer.

You must also read and understand the following instructions concerning electrical safety.

- 1.1.1. The **Electricity at Work Act 1989** requires that all portable electrical appliances, if used on business premises, are tested by a qualified electrician, using a Portable Appliance Tester (PAT), at least once a year.
- 1.1.2. The **Health & Safety at Work Act 1974** makes owners of electrical appliances responsible for the safe condition of those appliances and the safety of the appliance operators. **If in any doubt about electrical safety, contact a qualified electrician.**

- 1.1.3. Ensure that the insulation on all cables and on the appliance is safe before connecting it to the power supply. See 1.1.1. and 1.1.2. and use a Portable Appliance Tester.
- 1.1.4. Ensure that cables are always protected against short circuit and overload.
- 1.1.5. Regularly inspect power supply cables and plugs for wear or damage and check all connections to ensure that none is loose.
- 1.1.6. **Important:** Ensure that the voltage marked on the appliance matches the power supply to be used and that the plug is fitted with the correct fuse - see fuse rating at right.
- 1.1.7. **DO NOT** pull or carry the appliance by the power cable.
- 1.1.8. **DO NOT** pull the plug from the socket by the cable.
- 1.1.9. **DO NOT** use worn or damaged cables, plugs or connectors. Immediately have any faulty item repaired or replaced by a qualified electrician. When a BS 1363/A UK 3 pin plug is damaged, cut the cable just above the plug and **dispose of the plug safely.**

- a) Connect the **GREEN/YELLOW** earth wire to the earth terminal 'E'.
- b) Connect the **BROWN** live wire to the live terminal 'L'.
- c) Connect the **BLUE** neutral wire to the neutral terminal 'N'.

- d) **After wiring, check that there are no bare wires, that all wires have been correctly connected, that the cable outer insulation extends beyond the cable restraint and that the restraint is tight.**

Double insulated products, which are always marked with this symbol , are fitted with live (brown) and neutral (blue) wires only. To rewire, connect the wires as indicated above - **DO NOT** connect either wire to the earth terminal.

- 1.1.10. If an extension reel is used it should be fully unwound before connection. A reel with an RCD fitted is preferred since any appliance plugged into it will be protected. The cable core section is important and should be at least 1.5mm², but to be absolutely sure that the capacity of the reel is suitable for this product and for others which may be used in the other output sockets, we recommend the use of 2.5mm² section cable.

1.2. GENERAL SAFETY

- WARNING!** Ensure that Health & Safety, local authority and general workshop practice regulations are adhered to when using this equipment.
- ✓ Familiarise yourself with the application, limitations and hazards of the saw.
- WARNING!** Disconnect the saw from the mains power and ensure that the cutting blade is at a complete standstill before attempting to change blades or perform any maintenance.
- ✓ Maintain the saw in good condition (use an authorised service agent).
- ✓ Replace or repair damaged parts. Use genuine parts only. Unauthorised parts may be dangerous and will invalidate the warranty.
- WARNING!** Keep all guards and holding screws in place, tight and in good working order. Check regularly for damaged parts. A guard or any other part that is damaged should be repaired or replaced before the machine is used. The safety guard is a mandatory fitting where the saw is used on premises covered by the Health & Safety at Work Act.
- ✓ Locate saw in a suitable work area and keep area clean and tidy and free from unrelated materials. Ensure that there is adequate lighting.
- ✓ Keep the saw clean and blades sharp for best and safest performance.
- ✓ Ensure that there are no flammable or combustible materials in or near the work area.
- WARNING!** Always wear approved eye or face protection when operating the saw. Use a face or dust mask if dust is generated.
- ✓ Maintain correct balance and footing. Ensure the floor is not slippery and wear non-slip shoes.
- ✓ Remove ill fitting clothing. Remove ties, watches, rings and other loose jewellery and contain and/or tie back long hair.

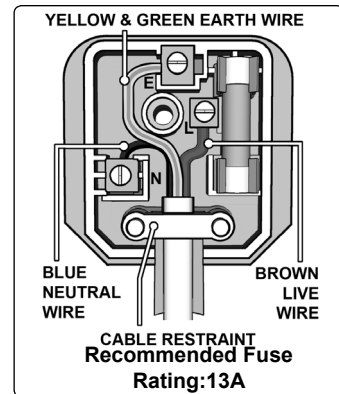

- ✓ Keep children and unauthorised persons away from the work area.
- ✓ Check moving parts alignment on a regular basis.
- ✓ Remove adjusting keys and wrenches from the machine and its vicinity before turning it on.
- ✓ Avoid unintentional starting.
- x **DO NOT** use the saw for any purpose other than that for which it is designed.
- x **DO NOT** operate the saw if any parts are damaged or missing as this may cause failure and/or personal injury.
- ☐ **WARNING! DO NOT** cut any materials containing asbestos.
- x **DO NOT** switch on the saw whilst the blade is in contact with the workpiece.
- x **DO NOT** attempt to cut a workpiece so small that you have to remove the finger guard.
- ✓ Always provide additional support, at table height, for large workpieces.
- x **DO NOT** use the saw out of doors.
- x **DO NOT** get the saw wet or use in damp or wet locations or areas where there is condensation.
- x **DO NOT** allow untrained persons to operate the saw.
- x **DO NOT** allow children to operate the saw.
- x **DO NOT** operate the saw when you are tired or under the influence of alcohol, drugs or intoxicating medication.
- x **DO NOT** leave the saw operating unattended.
- x **DO NOT** pull the cable from the power supply.
- ✓ Use a qualified person to lubricate and maintain the saw.
- ✓ When not in use, switch the saw off, disconnect from the power supply and store in a childproof area.

2. INTRODUCTION & SPECIFICATION

2.1. Introduction

Fully CE approved scroll saw with quality rounded table. Features parallel arm design and quick blade changing system. Variable speed operation to cut multiple types of materials. Fitted with adjustable safety guard and flexible dust blower.

2.2. Specification

Throat Depth	406mm	Table Size	400 x 253mm
Max. Cut	50mm	Table Tilt.	0-45°
Stroke.	15mm	Motor	120W/230V
Speed.	400 - 1600spm		

3. GLOSSARY: WOODWORKING TERMS

Bevel Cut: A cutting operation made with the saw table at any angle other than 90° to the blade.

Compound Mitre Cut: A compound mitre cut is a mitre cut with a bevel.

Crosscut: Cut made across the grain or width of the workpiece.

Freehand (for scroll saw): Performing a cut without the workpiece being guided by a fence or mitre gauge. The workpiece must be supported by the table.

Gum: A sticky, sap based residue of wood products.

Kerf: The material removed by the blade in a through cut or the slot produced by the blade in a non-through or partial cut.

KickBack: Projection of the workpiece. Sudden recoil of the workpiece usually due to the workpiece not being against the fence, hitting the blade or being accidentally pushed against the blade instead of a kerf being sawn in the workpiece.

Leading End: The end of the workpiece pushed into the cutting tool first.

Push Stick: A device which is used to feed the workpiece through the saw blade during narrow ripping operations and which helps keep the operator's hands well away from the blade.

Resaw: A cutting operation to reduce the thickness of the workpiece to make thinner pieces.

Ripping: A cutting operation along the length of the workpiece.

Saw Blade Path: The area directly in line with the blade (over, under, behind, or in front of it). As it applies to the workpiece, the area which will be, or has been, cut by the blade.

Set: Operation which consists in setting the tip of the saw blade teeth to the right or left to improve clearance and make it easier for the body of the blade to penetrate the material.

SPM: Strokes per minute. Used in reference to blade movement.

Through cut: Any cutting operation where the blade cuts through the entire thickness of the workpiece.

Workpiece: The item which is being cut. The surfaces of a workpiece are commonly referred to as faces, ends, and edges.

Worktable: The surface on which the workpiece rests during a cutting or sanding operation.

4. CONTENT & ASSEMBLY

▲ **IMPORTANT! DO NOT attempt to lift saw by holding the upper blade arm as this will cause damage. Lift by the base only.**

☐ **WARNING! DO NOT plug saw into mains until assembly is complete and saw has been firmly mounted to work surface.**

4.1. Content

- 4mm Hex Key Fig.1
- Saw Blade Fig.2

The following tools (not included) are needed for adjustment and alignment:

Fig.3

- A. PHILLIPS SCREWDRIVER
- B. SLOTTED SCREWDRIVER
- C. SQUARE

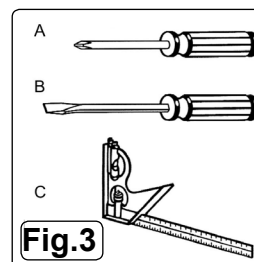
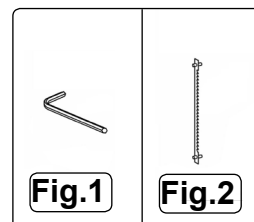

4.2. MAIN PARTS DESCRIPTION

Before attempting to use your saw, familiarise yourself with all the operating features and safety requirements of your scroll saw. See Fig.4

- Sawdust Blower:** Keeps the line of cut on the workpiece clean for more accurate scroll cuts. For best results, always direct the airflow at the blade and the workpiece.
- Saw Table with Throat Plate:** Your scroll saw has a saw table with tilt control for maximum accuracy. The red throat plate, inserted in the saw table, allows for blade clearance.
- Switch:** Your scroll saw has an easy access power switch. 0 = OFF I=ON
- Table Lock:** Allows you to tilt the table and lock it at the desired angle (up to 45°).
- Bevel Scale:** The bevel scale shows you the degree at which the saw table is tilted.
- Drop Foot:** This foot should always be lowered until it just rests on top of the workpiece to prevent it from lifting, yet not so much as to make the workpiece drag.
- Blade Clamp Screws:** Blade clamp screws are used to tighten and loosen the blade clamps when changing saw blades.
- Drop Foot Lock:** This allows you to raise or to lower the drop foot and lock it in the required position.
- Blade Tensioner & Adjuster:** To loosen or tighten blade tension, flip the lever over centre and turn the blade tension wheel.
- Speed Selector:** Turn to adjust the speed from 400 to 1,600 strokes per minute.
- Sawdust Outlet:** This feature will allow you to attach any 1¼ in. (32 mm) vacuum hose for easy sawdust collection.

Fig. 4

- | | | |
|-------------------|---|-------------------|
| A. SAWDUST BLOWER | F. BEVEL SCALE | K. MOTOR |
| B. SAW BLADE | G. DROP FOOT | L. SPEED SELECTOR |
| C. THROAT PLATE | H. BLADE | M. SAWDUST OUTLET |
| D. SWITCH | I. DROP FOOT LOCK | N. SAW TABLE |
| E. TABLE LOCK | J. BLADE TENSION LEVER & ADJUSTER WHEEL | O. SAFETY GUARD |

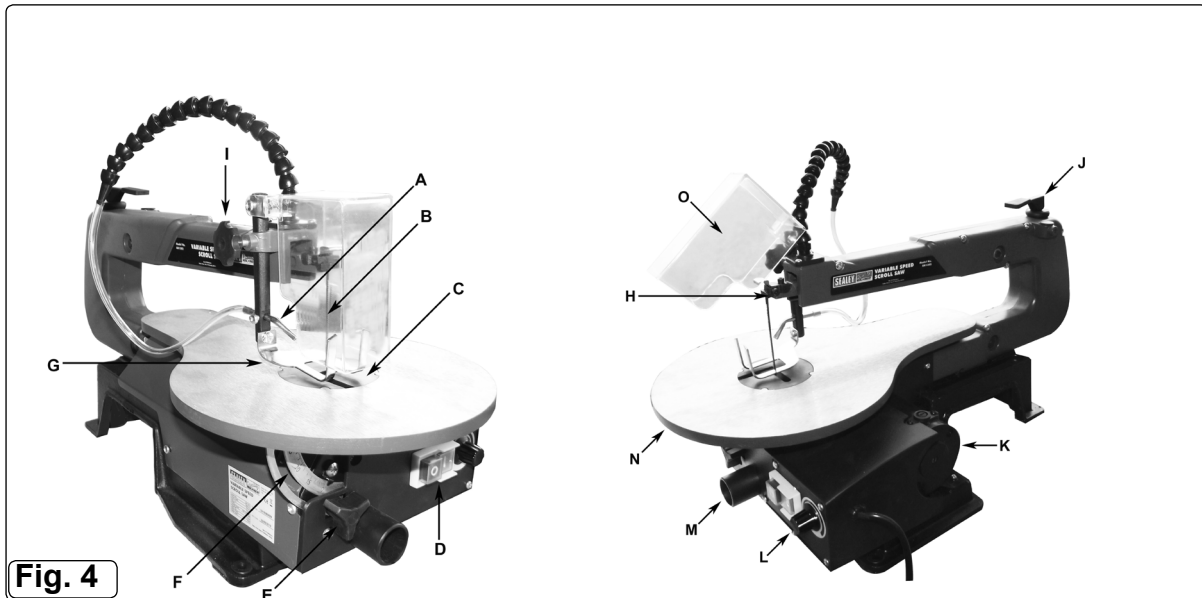

Fig. 4

4.3. BOLTING THE SCROLL SAW ONTO A WORKBENCH. See Fig.5

WARNING! To avoid serious personal injury from unexpected tool movement, securely mount the scroll saw onto a workbench. If the scroll saw is to be used in a specific location, we recommend that you secure it to a workbench in a permanent way. For this purpose, holes should be drilled through the supporting surface of the workbench.

- 4.3.1. Each hole in the base of the saw should be bolted securely using machine bolts, washers, and nuts (not included).
 - 4.3.2. Bolts should be long enough to accommodate the saw base, washers, nuts, and the thickness of the workbench.
 - 4.3.3. Place the scroll saw on the workbench. Using the saw base as a pattern, locate and mark the holes where the scroll saw is to be mounted.
 - 4.3.4. Drill four holes through the workbench.
 - 4.3.5. Place the scroll saw on the workbench aligning the holes in the saw base with the holes drilled in the workbench.
 - 4.3.6. Insert all four bolts (not included) and tighten securely with washers and nuts (not included).
- Note: All bolts should be inserted from the top. Fit the washers and nuts from the underside of the bench.*

The supporting surface where the scroll saw is mounted should be examined carefully after mounting to insure that no movement will occur while cutting.

Fig.5

- | | |
|-------------|-------------------|
| A. G-CLAMP | D. WORKBENCH |
| B. SAW BASE | E. MOUNTING BOARD |
| C. G-CLAMP | |

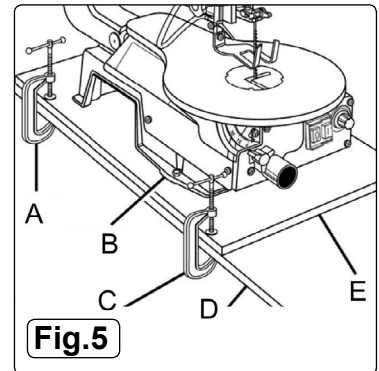

Fig.5

4.4. CLAMPING THE SCROLL SAW TO THE WORKBENCH. See Fig.5

If the scroll saw is to be used in several different places, it is recommended that you fasten it permanently to a mounting board that can easily be clamped to a workbench or other supporting surface. The mounting board should be large enough to prevent the saw from tipping while in use. Any good grade plywood or chipboard with a 3/4in. (19mm) thickness is recommended.

- 4.4.1. Mount the saw onto the board using the holes in the saw base as a template for the hole pattern. Locate and mark the holes on the board.
- 4.4.2. Follow the last three steps in the previous section called Mounting the Scroll Saw onto a Workbench.
- 4.4.3. Make sure they are long enough to go through the holes in the saw base, the board on which the saw is mounted, and the washers and nuts.

Note: It will be necessary to countersink the washers and nuts on the bottom side of mounting board.

4.5. ADJUSTMENTS

- WARNING!** To prevent accidental starting that could cause serious injury, turn off the saw and unplug it from the power source before making any adjustments.
- 4.5.1. To prevent the workpiece from lifting, the drop foot should be adjusted so it just rests on top of the workpiece. The drop foot should not be adjusted so tightly that the workpiece drags. (See Fig.6)
- 4.5.2. Always retighten the drop foot lock after each adjustment has been made.
- 4.5.3. Loosen the drop foot lock.
- 4.5.4. Lower or raise the drop foot to the desired position.
- 4.5.5. Retighten the drop foot lock.
- 4.5.6. The two prongs at the front of the drop foot act as a blade guard to prevent the user from accidentally touching the blade.

Fig.6

- | | |
|-------------------|---------------------|
| A. DROP FOOT LOCK | D. SAWDUST BLOWER |
| B. PUMP MECHANISM | E. ARTICULATED HOSE |
| C. DROP FOOT | F. FLEXIBLE HOSE |

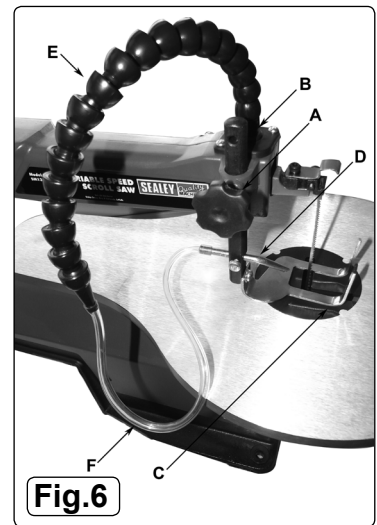

4.6. SAWDUST BLOWER. See Fig.6

- WARNING!** To avoid accidental starting which could result in serious injury, turn the saw off, and unplug from the power source.
- 4.6.1. The sawdust blower is designed and preset to direct air to the most effective point on the cutting line. Screw the articulated hose into the threaded port on the pump mechanism then connect the flexible hose to the nozzle.
- 4.6.2. Alternatively; the articulated hose can be used on its own if more suitable
- 4.6.3. Make sure the drop foot is properly adjusted to secure the workpiece and direct air at the cutting surface.

4.7. SQUARING THE SAW TABLE TO THE BLADE. See Fig.7

WARNING! To avoid accidental starting which could result in serious injury, turn the saw off and unplug from the power source.

- 4.7.1. Loosen the drop foot lock and move the drop foot rod all the way up.
- 4.7.2. Retighten the drop foot lock.
- 4.7.3. Loosen the table lock and tilt the saw table until it is approximately at right angles to the blade.
- 4.7.4. Place a small square on the saw table next to blade and lock the table at 90° to block.
- 4.7.5. Loosen the screw holding the scale indicator. See Fig.8. Move the indicator to the 0° mark and securely tighten the screw. Remember, the bevel scale is a convenient guide but should not be relied upon for precision. Make practice cuts on scrap material to determine if your angle settings are correct. Adjust the drop foot to the desired position and securely retighten the drop foot lock.

Fig.7

- | | |
|------------------|-------------------|
| A. DROP FOOT ROD | D. SMALL SQUARE |
| B. DROP FOOT | E. DROP FOOT LOCK |
| C. TABLE LOCK | |

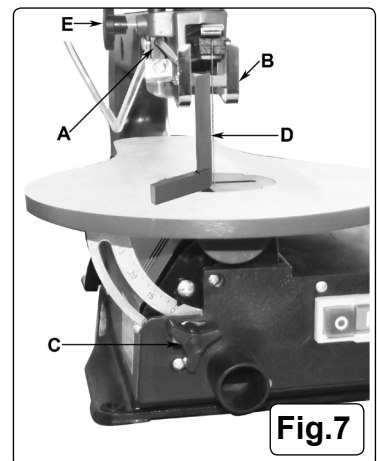

4.8. SETTING THE TABLE FOR HORIZONTAL OR BEVEL CUTTING See Fig.8

- WARNING!** To avoid accidental starting which could result in serious injury, turn the saw off and unplug from the power source.
- A bevel scale is located under the saw table as a convenient guide for setting the approximate saw table angle for bevel cutting. When greater precision is required, make practice cuts on scrap material and adjust the saw table as necessary for your requirements.

Note: When cutting bevels, the drop foot should be tilted so it is parallel to the saw table and rests flat on the workpiece. To tilt the drop foot, loosen the screw, tilt the drop foot to the proper angle, then retighten the screw.

WARNING! To avoid accidental starting which could result in serious injury, turn the saw off, and unplug from the power source.

Fig.8

- | | |
|----------------|--------------------|
| A. BEVEL SCALE | C. TABLE LOCK |
| B. SCREW | D. SCALE INDICATOR |

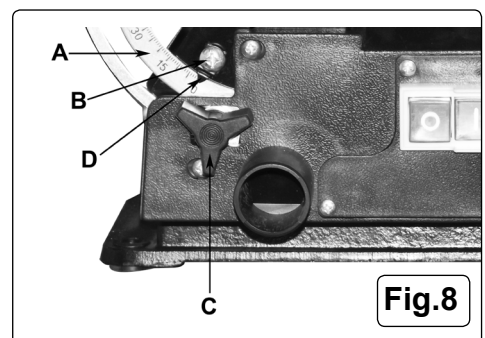

4.9. ADJUSTING THE DROP FOOT

- 4.9.1. Loosen the drop foot lock. See Fig.4.
- 4.9.2. Position the drop foot so the saw blade is in its centre.
- 4.9.3. Tighten the drop foot lock.

4.10. ADJUSTING BLADE TENSION. See Fig.9

WARNING! To avoid accidental starting which could result in serious injury, turn the saw off, and unplug from the power source.

- 4.10.1. To release initial tension, flip the blade tension lever over.
- 4.10.2. Turning the blade tension wheel anticlockwise decreases (or loosens) blade tension.
- 4.10.3. Turning the blade tension wheel clockwise increases (or tightens) blade tension.
Note: You can adjust blade tension at any time. Check tension by the sound the blade makes when plucked like a guitar string.
- 4.10.4. Pluck the back straight edge of the blade while turning the tension adjusting. The sound should be a musical note. The sound becomes less flat as tension increases. The sound level decreases with too much tension.
- 4.10.5. Flip the tension lever back over centre to re-tension the blade.
Note: Be careful not to adjust the blade too tight. Too much tension may cause the blade to break as soon as you start cutting. Too little tension may cause the blade to bend or break before the teeth wear out.

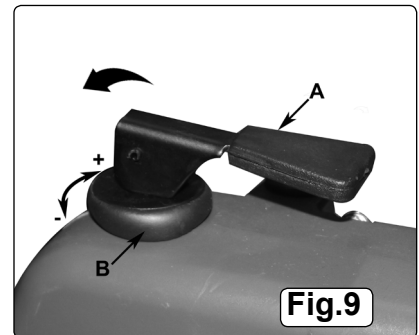

Fig.9

A. TENSION LEVER

B. BLADE TENSION ADJUSTMENT WHEEL

4.11. FITTING BLADES

Scroll saw blades wear out quickly and must be replaced frequently for optimum cutting results. Expect to break some blades while you learn to use and adjust your saw. Blades usually become dull after 1/2hour to 2hours of cutting, depending on the type of material and speed of operation. Removing the Saw Blade:

- 4.11.1. Turn off the saw and unplug it from the power source.
- 4.11.2. Turn the blade tension wheel anticlockwise to decrease (or loosen) blade tension. See Fig.4
- 4.11.3. Pushing up from under the saw table, remove the throat plate.
- 4.11.4. Loosen both the upper and lower blade clamp screws with the T-handle hex key or by hand.
- 4.11.5. Pull up on the blade and push down on the saw arm to disengage the upper pins from the V-notch of the upper blade holder. Pull the blade downward to disengage the lower pins from the V-notch of the lower blade holder.
- 4.11.6. Place the new blade through the opening in the saw table with the teeth to the front of the saw and pointing down towards the saw table. The pins on the blade fit into the V-notch of the lower blade holder.
- 4.11.7. Pull up on the blade and press the upper arm down to position the pins of the blade in the V-notch in the upper blade holder.
- 4.11.8. Securely tighten the upper and lower blade clamps with the T-handle hex key or by hand. Turn the blade tension wheel clockwise until the blade has the desired amount of tension.
- 4.11.9. Replace the throat plate.

Note: If the blade touches the drop foot on either side, then the drop foot must be adjusted. See section on Adjusting the Drop Foot.

5. OPERATION

5.1. OPERATION

Note: Before starting a cut, turn the saw on and listen to the sound it makes. If you notice excessive vibration or an unusual noise, stop the saw immediately and unplug it. Do not restart the saw until you have located and corrected the problem.

Note: After the saw is turned on, a hesitation before blade movement is normal.

- 5.1.1. There is a learning curve for each person who uses this saw. During that period of time it is expected that some blades will break until you learn how to use and adjust the saw correctly. Plan the way you will hold the workpiece from start to finish.
- 5.1.2. Keep your hands away from the blade. Do not-hand hold pieces so small that your fingers would have to go under the drop foot.
- 5.1.3. Hold the workpiece firmly against the saw table.
- 5.1.4. The blade teeth cut the workpiece only on the down stroke. Use gentle pressure and both hands when feeding the workpiece into the blade. Do not force the cut.
- 5.1.5. Guide the workpiece into the blade slowly because the blade teeth are very small and can only remove material on the down stroke. Avoid awkward operations and hand positions where a sudden slip could cause serious injury from contact with the blade. Never place your hands in the blade path.
- 5.1.6. For accurate wood cuts, compensate for the blades tendency to follow the wood grain as you are cutting. Use extra supports (table, blocks, etc.) when cutting large, small or awkward workpieces.
- 5.1.7. Never use another person as a substitute for a table extension or as an additional support for a workpiece that is longer or wider than the basic saw table.
- 5.1.8. When cutting irregularly shaped workpieces, plan your cut so the workpiece will not pinch the blade. Workpieces must not twist, rock or slip while being cut.

5.2. JAMMING OF SAW BLADE AND WORKPIECE

When backing out the workpiece, the blade may bind in the kerf (cut). This is usually caused by sawdust clogging the kerf or by the blade coming out of the blade holders. If this happens:

- 5.2.1. Place the switch in the OFF position.
- 5.2.2. Wait until the saw has come to a full and complete stop. Unplug the saw from the power source.
- 5.2.3. Remove the blade and the workpiece, see section on Removing the Saw Blade.
- 5.2.4. Wedge the kerf open with a flat screwdriver or wooden wedge then remove the blade from the workpiece .

WARNING! Before removing offcuts from the table, turn the saw off and wait for all moving parts to come to a full stop to avoid serious personal injury.

5.3. CHOOSING THE RIGHT BLADE AND SPEED

The scroll saw accepts a wide variety of blade widths and thicknesses for cutting wood and other fibrous materials. The blade width and thickness and the number of teeth per inch or centimetre are determined by the type of material and the size of the radius being cut.

Note: As a general rule, always select narrow blades for intricate curve cutting and wide blades for straight and large curve cutting.

5.4. BLADE INFORMATION

Scroll saw blades wear out and must be replaced frequently for optimum cutting results. Scroll saw blades generally become dull after 1/2 hour to 2 hours of cutting, depending on the type of material and speed of operation.

When cutting wood, best results are achieved with pieces less than one inch (25mm) thick.

When cutting wood thicker than one inch (25mm), the user must guide the workpiece very slowly into the blade and take extra care not to bend or twist the blade while cutting.

5.5. SPEED SETTING. See Fig.10

5.5.1. By turning the speed selector, the saws speed may be adjusted from 400 to 1,600SPM (Strokes Per Minute). To increase the strokes per minute, turn the speed selector clockwise.

5.5.2. To decrease the strokes per minute, turn the speed selector anticlockwise.

Fig.10

A. TO INCREASE B. TO DECREASE

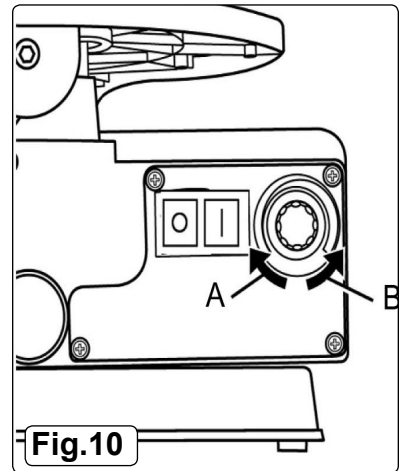

5.6. SCROLL CUTTING

In general, scroll cutting consists in following the pattern lines by pushing and turning the workpiece at the same time. Once you have started a cut, do not try to turn the workpiece without pushing it - the workpiece could bind or twist the blade.

WARNING! To prevent serious personal injury, never leave the saw unattended until the blade has come to a complete stop.

5.7. INTERIOR SCROLL CUTTING See Fig.11

5.7.1. One feature of a scroll saw is that it can be used to make scroll cuts within a workpiece without breaking or cutting through the edge or perimeter of the workpiece.

5.7.2. To make interior cuts in the workpiece, remove the scroll saw blade as explained in the section on Installing Blades.

5.7.3. Drill a 1/4in. (6mm) hole in the workpiece.

5.7.4. Place the workpiece on the saw table with the drilled hole over the hole in the table.

5.7.5. Fit the blade, feeding it through the hole in the workpiece; then adjust the drop foot and blade tension.

5.7.6. When finished making the interior scroll cut, simply remove the blade from the blade holders as described in the section on Installing Blades, and remove the workpiece from the saw table.

Fig.11

A. DRILL HOLE C. WORKPIECE
B. INTERIOR CUT

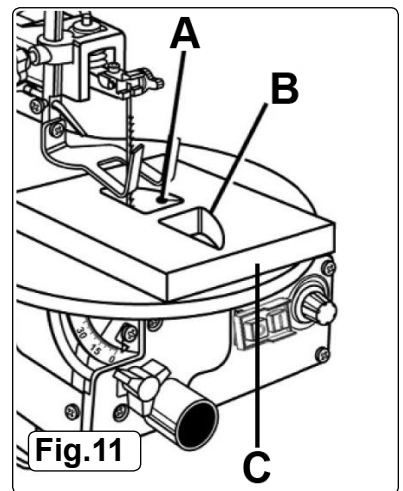

5.8. STACK CUTTING. See Fig.12

Once you have become well acquainted with your saw through practice and experience, you may wish to try stack cutting.

Stack cutting may be used when several identical shapes need to be cut. Several workpieces may be stacked one on top of the other and secured to each other before cutting. Pieces of wood may be joined together by placing double sided tape between each piece or by wrapping tape around the corners or ends of the stacked wood. The stacked pieces must be attached to each other in such a way that they can be handled on the table as a single workpiece.

WARNING! To avoid serious personal injury, do not cut several workpieces at a time unless they are properly attached to each other.

Fig.12

A. WOOD PIECES B. TAPE

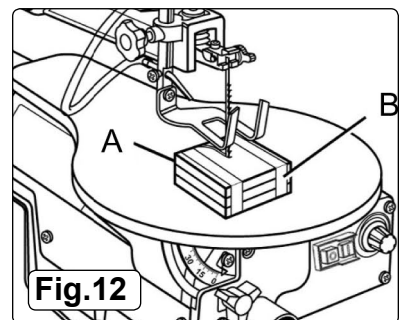

6. MAINTENANCE

WARNING! When replacing parts, use only authorised replacement parts. The use of any other spare parts may create a hazard or damage your saw.

6.1. GENERAL MAINTENANCE

6.1.1. Keep your scroll saw clean.

6.1.2. Do not allow pitch to accumulate on the saw table. Clean it with a suitable cleaner.

6.2. ARM BEARINGS. See Fig.13

Lubricate the arm bearings after the first 10 hours of use. Oil them ever 50 hours of use or whenever there is a squeak coming from the bearings.

6.2.1. Carefully place the saw on its side as shown in Fig.15. Remove the rubber cap from the upper and the lower arm of the saw.

6.2.2. Squirt a few drops of oil on the end of the shaft and arm bearings. Leave the saw in this position overnight to let the oil soak in.

Note: Lubricate the bearings on the other side of the saw in the same manner.

WARNING! If the power cord is worn, cut, or damaged in any way, have it replaced immediately by a qualified service technician. Failure to do so could result in serious personal injury.

Fig.13

A. ARM BEARINGS

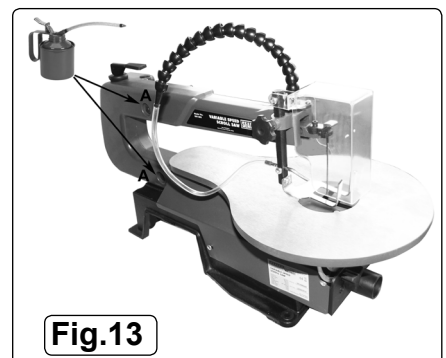

6.3. CARBON BRUSHES. See Fig.14

Your saw has externally accessible carbon brushes that should be checked periodically for wear. When one of the two brushes becomes worn, replace both brushes.

Unplug the saw from the power source.

- 6.3.1. Using a flat blade screwdriver, remove the bottom brush assembly cap through the access hole in the base and the top brush assembly cap from the top of the motor.
 - 6.3.2. Gently pry the brush assemblies out using a small screwdriver, the pointed end of a nail, or a paper clip.
 - 6.3.3. If one of the brushes is worn down shorter than 1/4in. (6mm), replace both brushes. Do not replace one brush without replacing the other. Make sure the curvature at the end of the brushes matches the curvature of the motor and that each carbon brush moves freely in its brush holder.
 - 6.3.4. Make sure the brush cap is positioned correctly (straight). Tighten the carbon brush cap using a hand powered screwdriver only. Do not overtighten.
- WARNING!** To prevent accidental starting that could cause serious personal injury, turn off and unplug the saw before carrying out any maintenance work.
 - WARNING!** Failure to unplug your saw could result in accidental starting causing serious injury.

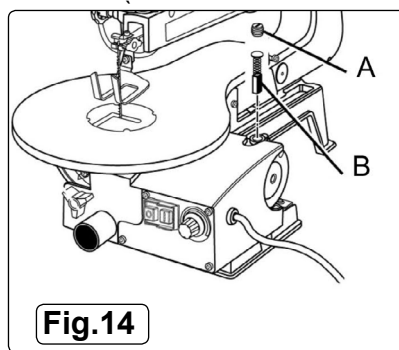

Fig.14

Fig.14

A. BRUSH CAP

B. CARBON BRUSH

7. TROUBLESHOOTING

PROBLEM	CAUSE	SOLUTION
Breaking blades	<ul style="list-style-type: none"> 1) Incorrect tension 2) Over-worked blade 3) Wrong blade 4) Twisting blade with workpiece 	<ul style="list-style-type: none"> 1) Adjust blade tension. 2) Feed workpiece more slowly. 3) Use narrow blades for thin workpieces, wide blades for thick. 4) Avoid side pressure, or twist, on blade.
Motor will not operate	<ul style="list-style-type: none"> 1) Power supply fault 2) Motor fault 	<ul style="list-style-type: none"> 1) Check power supply and fuses. 2) Contact local authorised Service Agent.
Vibration	<ul style="list-style-type: none"> 1) Mounting or mounting surface 2) Loose table 3) Loose motor 	<ul style="list-style-type: none"> 1) Ensure mount bolts are tight. The more solid the surface the less the vibration. 2) Tighten table lock and pivot screws. 3) Tighten motor mounting screws.
Blade run-out	<ul style="list-style-type: none"> 1) Blade holder(s) misaligned 	<ul style="list-style-type: none"> 1) Loosen blade holder screw(s) and realign.

8. OPTIONAL BLADES

Saw blades with hardened steel teeth suitable for cutting wood, plastics and thin metal sheet.

Model No: **SM43B10**

Blade Pitch: 10tpi

Pack Qty: 12

Model No: **SM43B15**

Blade Pitch: 15tpi

Pack Qty: 12

Model No: **SM43B20**

Blade Pitch: 20tpi

Pack Qty: 12

Model No: **SM43B25**

Blade Pitch: 25tpi

Pack Qty: 12

NOTE: This appliance is not intended for use by persons (including children) with reduced physical, sensory or mental capabilities or lack of experience and knowledge, unless they have been given supervision or instruction concerning the use of the appliance by a person responsible for their safety. Children should be supervised to ensure that they do not play with the appliance.



Environmental Protection.

Recycle unwanted materials instead of disposing of them as waste. All tools, accessories and packaging should be sorted, taken to a recycling centre and disposed of in a manner which is compatible with the environment.

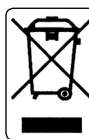

WEEE Regulations.

Dispose of this product at the end of its working life in compliance with the EU Directive on Waste Electrical and Electronic Equipment. When the product is no longer required, it must be disposed of in an environmentally protective way. Contact your local solid waste authority for recycling information.

NOTE: It is our policy to continually improve products and as such we reserve the right to alter data, specifications and component parts without prior notice.

IMPORTANT: No liability is accepted for incorrect use of this product.

WARRANTY: Guarantee is 12 months from purchase date, proof of which will be required for any claim.

INFORMATION: For a copy of our latest catalogue and promotions call us on 01284 757525 and leave your full name and address, including postcode.



Sole UK Distributor, Sealey Group,
Kempson Way, Suffolk Business Park,
Bury St. Edmunds, Suffolk,
IP32 7AR

01284 757500

01284 703534

www.sealey.co.uk

sales@sealey.co.uk