



# 100MM POWER BELT SANDER/LINISHER

MODEL NO: **SM100.V3**

Thank you for purchasing a Sealey product. Manufactured to a high standard, this product will, if used according to these instructions, and properly maintained, give you years of trouble free performance.

**IMPORTANT:** PLEASE READ THESE INSTRUCTIONS CAREFULLY. NOTE THE SAFE OPERATIONAL REQUIREMENTS, WARNINGS & CAUTIONS. USE THE PRODUCT CORRECTLY AND WITH CARE FOR THE PURPOSE FOR WHICH IT IS INTENDED. FAILURE TO DO SO MAY CAUSE DAMAGE AND/OR PERSONAL INJURY AND WILL INVALIDATE THE WARRANTY. KEEP THESE INSTRUCTIONS SAFE FOR FUTURE USE.



Refer to instructions



Wear eye protection



Wear ear protection



Wear a mask



Indoor use only

## 1. SAFETY

### 1.1. ELECTRICAL SAFETY

- WARNING!** It is the user's responsibility to check the following:
- ✓ Check all electrical equipment and appliances to ensure that they are safe before using. Inspect power supply leads, plugs and all electrical connections for wear and damage. Sealey recommend that an RCD (Residual Current Device) is used with all electrical products.
- ✓ Electrical safety information. It is important that the following information is read and understood:
- ✓ Ensure that the insulation on all cables and on the appliance is safe before connecting it to the power supply.
- ✓ Regularly inspect power supply cables and plugs for wear or damage and check all connections to ensure that they are secure.  
**Important:** Ensure that the voltage rating on the appliance suits the power supply to be used and that the plug is fitted with the correct fuse.
- ✗ **DO NOT** pull or carry the appliance by the power cable.
- ✗ **DO NOT** pull the plug from the socket by the cable. Guard against electric shock.
- ✗ **DO NOT** use worn or damaged cables, plugs or connectors. Ensure that any faulty item is repaired or is replaced immediately by a qualified electrician.
- ✓ If the cable or plug is damaged during use, switch off the electricity supply and remove from use.
- ✓ Ensure that repairs are carried out by a qualified electrician.  
If the cable or plug is damaged during use, switch off the electricity supply and remove from use.
- ✓ Replacement of the plug or the supply cord shall always be carried out by the manufacturer of the tool or their service organisation.
- ✓ Keep water clear of the electrical parts of the tool and away from persons in the working area.  
**Ensure that repairs are carried out by a qualified electrician.**

### 1.2. GENERAL POWER TOOL SAFETY WARNINGS

- WARNING!** Read all safety warnings and all instructions. This machine is intended to function as a sander. Operations such as grinding, wire brushing, polishing or cutting off are not recommended to be performed with this machine. Failure to follow the warnings and instructions may result in electric shock, fire and/or serious injury.
- WARNING!** Ensure that Health & Safety, local authority and general workshop practice regulations are adhered to when using this sander.
- ✗ **DO NOT** use the machine when any safety device is suspended or removed. If any defect is noticed stop using the machine.
- ✓ Save all warnings and instructions for future reference.

### 1.3. WORK AREA SAFETY

- ✓ Keep work area clean and well lit. Cluttered or dark areas invite accidents.
- ✓ Consider your work area environment:
- ✗ **DO NOT** expose sander to rain.
- ✗ **DO NOT** use tools in damp or wet locations.
- ✗ **DO NOT** operate power tools in explosive atmospheres, such as in the presence of flammable liquids, gases or dust. Power tools create sparks which may ignite the dust or fumes.
- ✓ Keep children and bystanders away while operating a power tool. Distractions can cause you to lose control.

### 1.4. OPERATIONAL SAFETY

- ✗ **DO NOT** use machine until it is assembled and installed according to instructions.
- ✓ Obtain training from a qualified person before using.
- ✓ Use with correctly installed/operating guards in place.
- ✓ Check belt for wear and tension and correct installation. If the belt is damaged or if it can not be tensioned properly, replace it.
- ✓ Ensure belt is tracking properly. Refer to 7.2 ADJUST BELT TRACKING.
- ✓ Keep arms, hands and fingers away from abrasive surfaces.
- ✓ Avoid awkward stance, operation and hand positions which could cause contact with the sanding surface.
- ✗ **DO NOT** wear gloves or hold the work piece with a rag.
- ✗ **DO NOT** start the machine with the work piece against the sanding surface.
- ✗ **DO NOT** start the machine until all objects (tools, scrap pieces etc.) have been removed from the machine.
- ✗ **DO NOT** sand work pieces shorter than 18cm (7") and thinner than 0.8mm (1/32").
- ✓ Properly support long or wide work pieces.
- ✓ Disconnect machine from mains supply and clean table/work area before leaving the machine. Lock the switch in the off position to prevent unauthorised use.

- ✓ Functional tests must be carried out before using the machine, including condition of belt, running speed and stop buttons.
  - ✓ Maintain the minimum distance between the sanding surface and the work piece rests and backstop.
- 1.5. PERSONAL SAFETY**
- ✓ Stay alert, watch what you are doing and use common sense when operating a sander. **DO NOT** use sander while you are tired or under the influence of drugs, alcohol or medication. A moment of inattention while operating power tools may result in serious personal injury.
  - ✓ Wear personal protective equipment. As appropriate, wear dust mask, hearing protectors, and workshop apron capable of stopping small abrasive or work piece fragments.
  - ✗ **DO NOT** operate the sander when you are tired or under the influence of alcohol, drugs or intoxicating medication.
  - ✓ Prevent unintentional starting. Ensure the switch is in the off-position before connecting to power source.
  - ✗ **DO NOT** overreach. Keep proper footing and balance at all times. This enables better control of the power tool in unexpected situations.
  - ✓ Dress properly. **DO NOT** wear loose clothing or jewellery. Keep your hair, clothing away from moving parts. Loose clothes, jewellery or long hair can be caught in moving parts.
  - ✓ Keep bystanders a safe distance away from work area. Anyone entering the work area must wear personal protective equipment.
  - ✓ Before using the machine check for damaged parts. Check for damage to, alignment and operation of parts. Any damage guard or any other part should be properly repaired or replaced.
  - ✓ Regularly clean the sanders air vents.
  - ✗ **DO NOT** stand on the machine.
  - ✗ **DO NOT** leave the machine until it has come to a complete stop or leave the machine running unattended.
  - ✓ Always use in well ventilated areas and provide for proper dust removal using a dust collection system.
  - ✓ If devices are provided for the connection of dust extraction and collection facilities, ensure these are connected and properly used.
  - ✗ **DO NOT** operate the machine near flammable materials, or outdoors or expose to damp or rain.
  - ✓ Remove adjusting keys/spanners before using the machine. Tools or scrap pieces can be ejected at high speed.
  - ✓ Never place your hand near a rotating accessory.
  - ✓ Only use recommended accessories.
- 1.6. POWER TOOL USE AND CARE**
- ✗ **DO NOT** force the machine. Use the correct machine for your application. The correct machine will do the job better and safer at the rate for which it was designed.
  - ✗ **DO NOT** use the machine if the switch does not turn it on and off. Any machine that cannot be controlled with the switch is dangerous and must be repaired.
  - WARNING!** Disconnect the plug from the mains supply before making any adjustments, changing accessories, cleaning or storage.
  - ✓ Store idle sander out of the reach of children and do not allow persons unfamiliar with the sander or these instructions to operate the sander. Power tools are dangerous in the hands of untrained users.
  - ✓ Maintain sander. Check for misalignment or binding of moving parts, breakage of parts and any other condition that may affect the sanders operation. If damaged, have the sander repaired before use. Many accidents are caused by poorly maintained power tools.
  - ✓ Use the sander in accordance with these instructions, taking into account the working conditions and the work to be performed. Use of the sander for operations different from those intended could result in a hazardous situation.
- 1.7. SERVICE**
- ✓ Have your sander serviced by a qualified repair person using only identical replacement parts. This will ensure that the safety of the sander is maintained. Unauthorised parts may be dangerous and will invalidate the warranty.
- 1.8. SPECIFIC SANDER SAFETY**
- WARNING!** Disconnect from mains supply and ensure that the belt is at a complete standstill before changing, servicing or performing any maintenance.
  - WARNING!** Keep all guards and holding screws in place, tight and in good working order. Keep machine in good condition at all times.
  - ✗ **DO NOT** use excessively oversized sanding belts. Follow the sanding belts manufacturer's recommendations.
  - ✓ Check regularly for damaged parts. A guard or any other part that is damaged must be repaired/replaced before the sander is next used.
  - ✓ Keep the sander clean for best and safest performance.
  - ✓ Before each use check all attachments for condition. If worn or damaged replace immediately.
  - ✗ **DO NOT** get the sander wet or use in damp or wet locations or areas where there is condensation.
  - ✗ **DO NOT** allow untrained persons to operate the sander.
  - ✓ Maintain the machine in top condition according to the Maintenance Section.
  - ✓ When not in use, unplug from the mains power supply and store in a safe, dry, childproof area.
- 1.9. LEAD PAINT WARNING!**
- Paint once contained lead as a traditional ingredient. The dust from the removal of such paint is toxic if inhaled or ingested and must, therefore, be avoided. The following action must be taken before using the sander on a surface that you suspect may have contained lead in the paint.
1. User must determine potential hazard relating to age of paint to be removed. (Modern paints do not contain lead).
  2. **DANGER!** Keep all persons and pets away from the work area. The following are particularly vulnerable to the effects of lead paint dust: Expectant women, babies and children.
  3. We recommend personal protection by using the following safety items:
    - a) Paint Spray Respirator (Sealey ref: SSP1699).
    - b) PE Coated Hooded Coverall (Sealey ref: SSP266).
    - c) Latex Gloves (Sealey ref: SSP24).
  4. Take adequate measures to contain the paint dust, flakes, and scrapings.
  5. Continue to wear safety equipment as in 3 above, and thoroughly clean all areas when task is complete. Ensure that paint waste is disposed of, in sealed bags or containers, according to local authority regulations.

## 2. INTRODUCTION

Suitable for metal and fabrication workshops. Robust construction designed for everyday use. Supplied with high quality abrasive belt. Graphite plate on the platen to reduce belt friction. Powerful 1500W 230V motor with IP54 protection. Bench or floor mounting (stand supplied).

### 3. SPECIFICATION

Model no:	SM100.V3
Belt Size(s):	100 x 1220mm
Belt Speed:	19m/s
Flat Grinding Surface:	100 x 280mm
Fuse Rating:	13A
Motor Power:	1500W
Nett Weight:	42kg
No-Load Speed:	2840rpm
Plug Type:	3-Pin
Power Supply Cable Length:	1.7m
Sound rating	87dB (A)

### 4. FEATURES

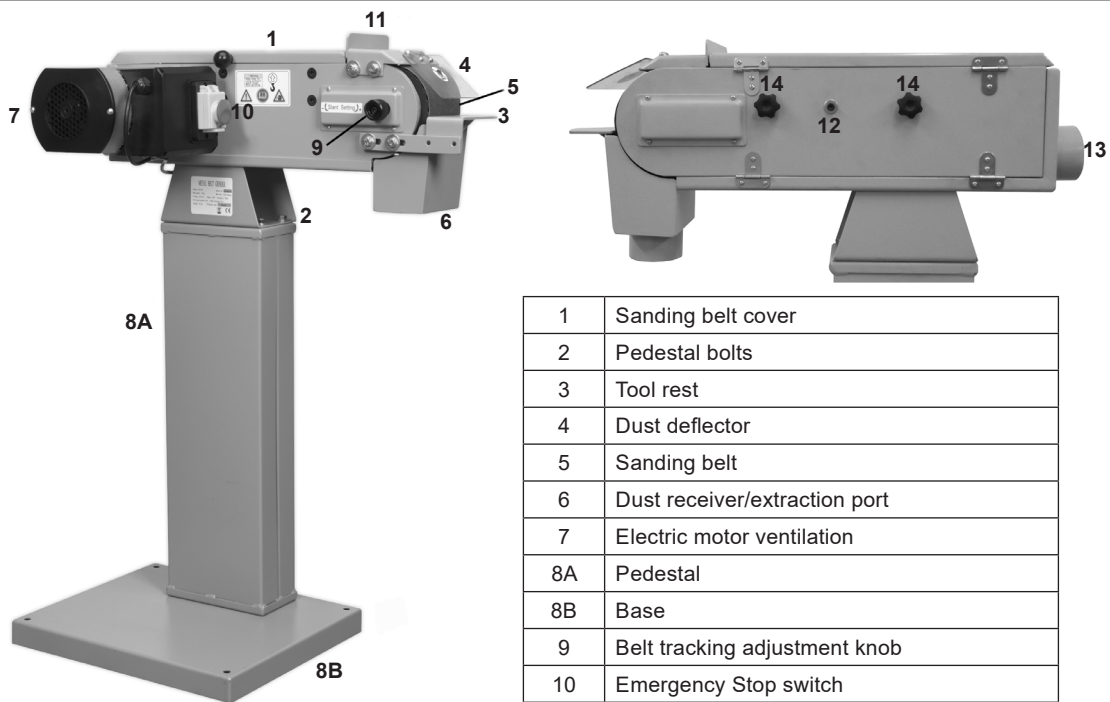

fig.1

1	Sanding belt cover
2	Pedestal bolts
3	Tool rest
4	Dust deflector
5	Sanding belt
6	Dust receiver/extraction port
7	Electric motor ventilation
8A	Pedestal
8B	Base
9	Belt tracking adjustment knob
10	Emergency Stop switch
11	Guard
12	Cover fixing bolt
13	Dust extraction port
14	Cover handles

### 5. ASSEMBLY & SETUP

- 5.1. Unpack the sander and check contents. If there are any damaged or missing parts contact your supplier immediately.
- 5.2. Refer to parts diagram at the back of these instructions to assist in assembly.
- 5.3. Bolt pedestal to base.
- 5.4. With assistance from at least 2 other persons lift the machine onto the pedestal (if it is being used) and bolt into position, fig 1.2.
- 5.5. Attach dust receiver, fig.1.6. With single screw.
- 5.6. Attach tool rest, fig.1.3, refer to section 7.4 for adjustment.
- 5.7. Attach guard, fig.1.11. Ensure guard bolts and cover fixing bolt, fig.1.12 are tight before use.
- 5.8. If a dust extraction system is available, connect it to the extraction port (diameter 52mm).

### 6. INSTALLATION

- 6.1. Site machine in an area with good ventilation and adequate lighting.
- 6.2. The machine should be fixed to a floor, or a bench, strong enough to take the weight of the machine, with 4 M10 bolts.
- 6.3. Minimum installation distance is 2m in front, 1.5m behind and 1m at each side of the machine.
- 6.4. The machine must be connected to a dust extraction system (not supplied).

### 7. OPERATION

- 7.1. Ensure that you have read, understand and apply the safety instructions in Section 1. The sander is designed to sand wooden work pieces held by hand.
  - ❑ **WARNING!** Before each use rotate the sanding belt by hand to check it is undamaged and secure. Remove adjusting keys and wrenches before turning the machine on.
  - ❑ **WARNING!** Functional tests must be carried out before using the machine, including condition of belt, running speed and stop buttons.

**7.2. ADJUST BELT TRACKING refer to fig.2**

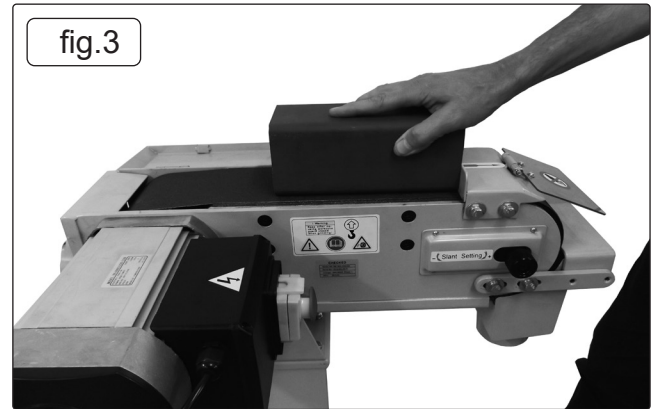
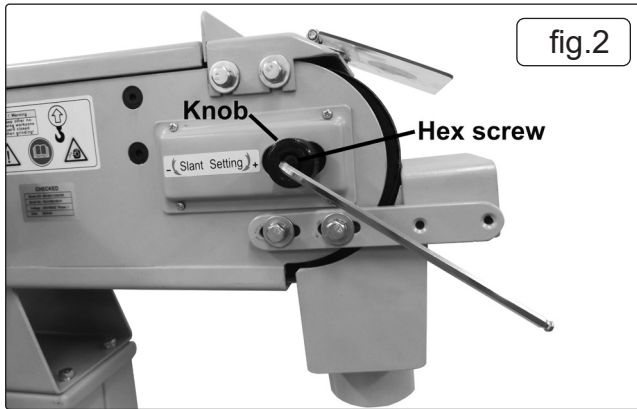

7.2.1. Loosen hex screw and twist knob clockwise or anticlockwise to adjust the sanding belt's tracking. Re-tighten the hex screw.

**7.3. FLAT TABLE LINISHING (TOP TABLE) Refer to fig.3**

7.3.1. Hold the work piece parallel to the belt, place against the guard and grip securely.

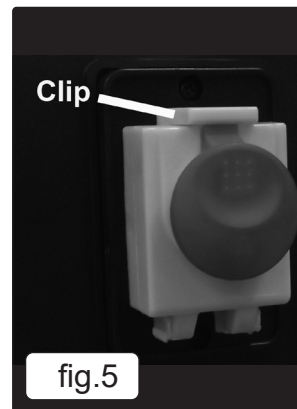
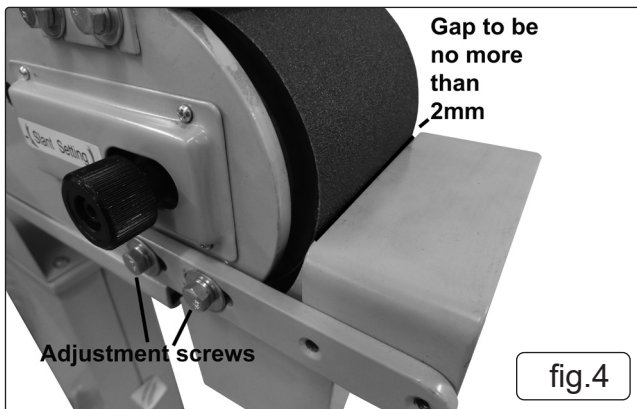

**7.4. CURVED SANDING WHEEL Refer to fig.4**

7.4.1. Adjust tool rest by loosening the 2 adjustment screws, so that the gap between the belt and the tool rest is no more than 2mm. Re-tighten screws. Grip work piece securely. Ensure work piece is kept square to the belt.

**7.5. NO VOLT RELEASE SWITCH refer to fig's 5 & 6**

7.5.1. Lift the clip on top of the switch housing, to let down the door to access the On/Off switch if the stop button has been used to turn the machine off.

**7.6. OPERATING THE SANDER**

7.6.1. Feed work piece carefully into the sanding disc, work methodically and **DO NOT** force the sander to remove material faster than it was designed for. Hold work piece with both hands and ensure that they are not in a position where they could slip up against the sanding belt.

7.6.2. Ensure large work pieces are supported at table height.

7.6.3. Turn sander off and make sure sanding belt is stationary before clearing scrap pieces from the table.

**8. MAINTENANCE**

❑ **WARNING!** Ensure machine is switched off and disconnected from the mains supply, before carrying out any maintenance.

**8.1. CHANGING THE BELT Refer to fig.7**

8.2. Remove dust receiver, fig.1.6.

8.3. Loosen cover fixing bolt, fig.1.12, and hinge open cover.

8.4. Pull lever fully forward to loosen belt tension, fig.2.

8.5. Slide off used belt and slide on new belt, observing the direction of travel.

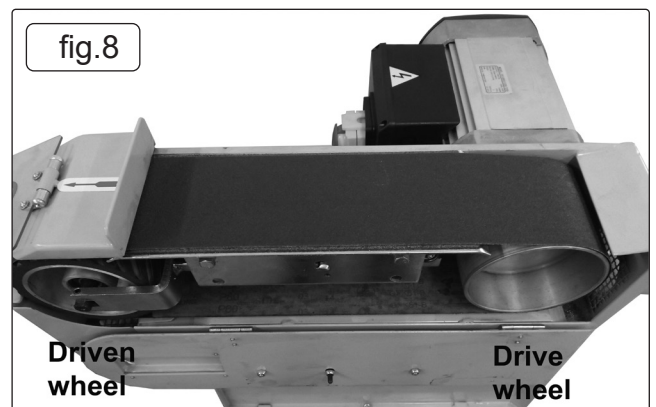
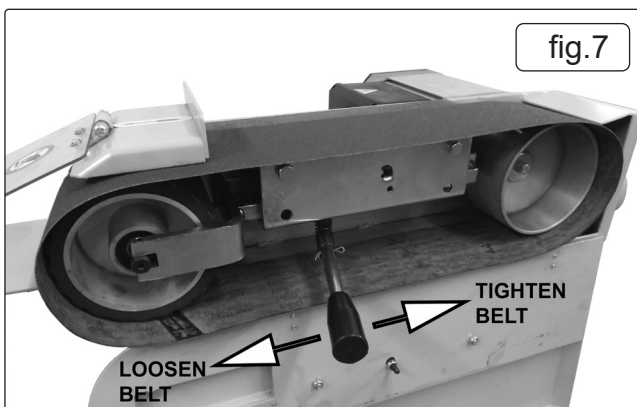

- 8.6. Align the belt so that it is perpendicular with the drive wheel and the driven wheel, see fig.8.
- 8.7. Push the lever back to re-tighten the belt.
- 8.8. Close the cover and secure the cover fixing bolt, fig.1.12.
- 8.9. Refit the dust receiver, fig.1.6.
- 8.10. Check tightness of all fixings before use, including work rests.
- 8.11. Restrict availability of keys or tools to skilled or instructed persons only.
- 8.12. Remove the plug before carrying out any adjustments, servicing or maintenance.
- 8.13. Switch the sander off when not in use or unattended.
- 8.14. All other service and maintenance must be carried out by an authorised Sealey stockist.
- 8.15. Visually check for belt wear before each use, replacing at the first sign of damage.
- 8.16. TRANSPORT AND STORAGE**
- 8.17. When not in use store in a safe, dry, childproof location.
- 8.18. CLEANING**
- 8.19. Keep machine and work area clean at all times, especially the motor air inlets.

## 9. TROUBLE SHOOTING

PROBLEM	CAUSE	SOLUTION
Motor will not run	1. Defective On/Off switch. 2. Motor unserviceable.	1. Replace switch. 2. Replace motor - professional repair only.
Machine slows down when sanding	1. Drive belt too tight. 2. Applying too much pressure to work piece, onto belt.	1. Decrease belt tension. 2. Ease up on pressure.
Sanding belt runs off the pulleys	1. Belt not tracking properly.	1. Adjust belt tracking. See section 7.2



### ENVIRONMENT PROTECTION

Recycle unwanted materials instead of disposing of them as waste. All tools, accessories and packaging should be sorted, taken to a recycling centre and disposed of in a manner which is compatible with the environment. When the product becomes completely unserviceable and requires disposal, drain any fluids (if applicable) into approved containers and dispose of the product and fluids according to local regulations.



### WEEE REGULATIONS

Dispose of this product at the end of its working life in compliance with the EU Directive on Waste Electrical and Electronic Equipment (WEEE). When the product is no longer required, it must be disposed of in an environmentally protective way. Contact your local solid waste authority for recycling information.

**Note:** It is our policy to continually improve products and as such we reserve the right to alter data, specifications and component parts without prior notice. Please note that other versions of this product are available. If you require documentation for alternative versions, please email or call our technical team on [technical@sealey.co.uk](mailto:technical@sealey.co.uk) or 01284 757505.

**Important:** No Liability is accepted for incorrect use of this product.

**Warranty:** Guarantee is 12 months from purchase date, proof of which is required for any claim.

Sealey Group, Kempson Way, Suffolk Business Park, Bury St Edmunds, Suffolk. IP32 7AR

01284 757500

[sales@sealey.co.uk](mailto:sales@sealey.co.uk)

[www.sealey.co.uk](http://www.sealey.co.uk)