

Thank you for purchasing a Sealey product. Manufactured to a high standard this product will, if used according to these instructions and properly maintained, give you years of trouble free performance.

⚠ IMPORTANT: PLEASE READ THESE INSTRUCTIONS CAREFULLY. NOTE THE SAFE OPERATIONAL REQUIREMENTS, WARNINGS AND CAUTIONS. USE THIS PRODUCT CORRECTLY AND WITH CARE FOR THE PURPOSE FOR WHICH IT IS INTENDED. FAILURE TO DO SO MAY CAUSE DAMAGE AND/OR PERSONAL INJURY AND WILL INVALIDATE THE WARRANTY. PLEASE KEEP INSTRUCTIONS SAFE FOR FUTURE USE.

1. SAFETY INSTRUCTIONS

1.1. ELECTRICAL SAFETY

⚠ WARNING! It is the user's responsibility to read, understand and comply with the following:

You must check all electrical equipment and appliances, before using, to ensure that they are safe. You must inspect power supply leads, plugs and all electrical connections for wear and damage. You must ensure the risk of electric shock is minimised by the installation of appropriate safety devices. An RCCB (Residual Current Circuit Breaker) should be incorporated in the main distribution board. We also recommend that an RCD (Residual Current Device) is used with all electrical products. It is particularly important to use an RCD with portable products that are plugged into an electrical supply not protected by an RCCB. If in doubt consult a qualified electrician. You may obtain a Residual Current Device by contacting your Sealey dealer. **You must** also read and understand the following instructions concerning electrical safety.

- 1.1.1. The **Electricity At Work Act 1989** requires all portable electrical appliances, if used on business premises, to be tested by a qualified electrician, using a Portable Appliance Tester (PAT), at least once a year.
- 1.1.2. The **Health & Safety at Work Act 1974** makes owners of electrical appliances responsible for the safe condition of the appliance and the safety of the appliance operator. **If in any doubt about electrical safety, contact a qualified electrician.**
- 1.1.3. Ensure the insulation on all cables and the product itself is safe before connecting to the mains power supply. See 1.1.1. & 1.1.2. above and use a Portable Appliance Tester (PAT).
- 1.1.4. Ensure that cables are always protected against short circuit and overload.
- 1.1.5. Regularly inspect power supply leads, plugs for wear and damage and power connections, to ensure that none is loose.
- 1.1.6. **Important:** Ensure the voltage marked on the product is the same as the electrical power supply to be used, and check that plugs are fitted with the correct capacity fuse. A 13 amp plug may require a fuse smaller than 13 amps for certain products, see fuse rating at right.
- 1.1.7. **DO NOT** pull or carry the appliance by the power supply lead.
- 1.1.8. **DO NOT** pull the plug from the socket by the power cable.
- 1.1.9. **DO NOT** use worn or damage leads, plugs or connections. Immediately replace or have repaired by a qualified electrician. A U.K. 3 pin plug with ASTA/BS approval is fitted. In case of damage, cut it off and fit a new plug according to the following instructions (discard old plug safely).

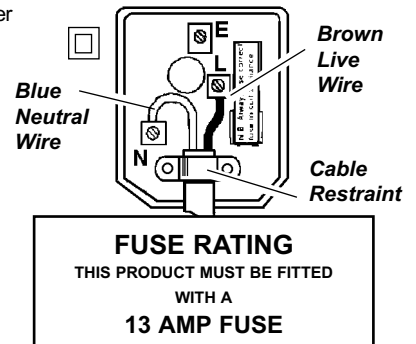

(UK only - see diagram at right). **Ensure the unit is correctly wired via a three-pin plug.**

a) Note that this saw is double insulated and therefore there is no GREEN/YELLOW earth wire.

b) Connect the BROWN live wire to live terminal 'L'.

c) Connect the BLUE neutral wire to the neutral terminal 'N'.

d) After wiring, check that there are no bare wires, that all wires have been correctly connected, that the cable outer insulation extends beyond the cable restraint and that the restraint is tight.

Double insulated products are fitted with live (BROWN) and neutral (BLUE) wires only. Double insulated products are always marked with this symbol . **To re-wire, connect the brown & blue wires as indicated above. DO NOT connect the brown or blue to the earth terminal.**

- 1.1.10. Some products require more than a 13 amp electrical supply. In such a case, **NO** plug will be fitted. **You must** contact a qualified electrician to ensure a 30 amp fused supply is available. We recommend you discuss the installation of a industrial round pin plug and socket with your electrician.
- 1.1.11. **Cable extension reels.** When a cable extension reel is used it should be fully unwound before connection. A cable reel with an RCD fitted is recommended since any product which is plugged into the cable reel will be protected. The section of the cores of the cable is important and should be at least 1.5mm², but to be absolutely sure that the capacity of the cable reel is suitable for this product and for others that may be used in the other output sockets, we recommend the use of 2.5mm² section cable.

1.2 GENERAL SAFETY

3 Familiarise yourself with the applications, limitations and potential hazards of the saw.

⚠ WARNING! Disconnect the saw from the mains power before changing accessories, servicing or performing any maintenance.

3 The machine must only be serviced by a qualified person or service agent. Contact your Sealey dealer for information.

3 Select a work area suitable for the saw and keep the area clean, tidy and free from unrelated materials. Ensure that there is adequate lighting.

3 Permanently mount the saw on a supporting surface strong enough to take the weight of the machine and workpiece.

3 Wood dust can be harmful to health by inhalation and skin contact. Concentrations of small dust particles in the air can form an explosive mixture. Ensure that there is adequate ventilation and that the saw is attached to a dust-extraction unit.

3 Maintain the saw in good condition, check moving parts alignment regularly. Keep saw blades clean and sharp.

3 Replace or repair damaged parts. *Use recommended parts only. Unauthorised parts may be dangerous and will invalidate the warranty.*

⚠ WARNING! Keep all guards and holding screws in place, tight and in good working order. Check regularly for damaged parts.

A guard, or any other part, that is damaged should be repaired or replaced before the saw is next used. The safety guard is a mandatory fitting where the saw is used in premises covered by the Health & Safety at Work Act.

3 Before commencing work, ensure the saw blade is set to cut in the correct direction, securely fastened, sharp and is compatible with the machine, spindle speed and the material to be cut. Never use a saw blade if damaged, bent or warped. Use only recommended saw blades.

3 Remove adjusting keys and wrenches from the machine and the vicinity before switching on.

3 Machine operators must have received sufficient training and instructions relating to the dangers associated with the machine, the precautions to be observed and the requirements of the Wood Working Machines Regulations. Operators must be under the adequate supervision of a person who has a thorough knowledge and experience of the machine and the appropriate regulations.

- 7 **DO NOT** operate the saw if any parts are damaged or missing as this may cause failure and/or personal injury.
- 7 **DO NOT** operate the saw when you are tired or under the influence of alcohol, drugs or intoxicating medication.
- 3 When not in use switch off the saw and unplug from the power supply.
- p **WARNING!** Wear approved safety eye protection, ear defenders and, if dust is generated, respiratory protection.
- 3 Remove ill fitting clothing. Remove ties, watches, rings and other loose jewellery and contain long hair.
- 3 Keep hands and body clear of the blade when operating the saw.
- 3 Maintain correct balance and footing. Ensure the floor is not slippery and wear non-slip shoes.
- 3 Keep children and unauthorised persons away from the work area.
- 3 Avoid unintentional starting and never leave the saw operating unattended.
- 7 **DO NOT** use the saw for a task it is not designed to perform and ensure operators are trained to use the saw.
- 7 **DO NOT** get the saw wet or use in damp or wet locations or areas where there is condensation.
- 7 **DO NOT** use the saw where there are flammable liquids, solids or gases such as paint solvents and including waste cleaning rags etc.

1.3. SPECIFIC SAW SAFETY RULES

- 3 Connect to a suitable extraction system. Failure to do so will result in the build-up of sawdust which could become a fire hazard.
- 3 Keep blade guard in place and operational.
- p **WARNING!** Before each use, check that the saw blade is secure and not worn or damaged.
- 3 Check workpiece to ensure that there are no nails or other items which may foul the saw blade.
- 3 Clamp the workpiece firmly against the fence.
- 3 Avoid subjecting the saw blade to excessive strain - never force the blade down. Maintain a controlled, steady progression.
- 3 Should the saw blade jam, switch the power off immediately to prevent damage to the motor.
- 3 Provide adequate support to the sides of the saw table for long or wide workpieces.
- 3 Always use the workpiece clamp provided if at all possible. If the workpiece can only be hand-held take extreme care.
- 7 **DO NOT** place yourself in an awkward operating position where a slip could cause your hand to move into the cutting blade.
- 7 **DO NOT** stand, or have any part of your body, in line with the path of the saw blade.
- 7 **DO NOT** hold what will become the off-cut (the waste part of the workpiece).
- p **WARNING! DO NOT** put hands anywhere near the blade whilst it is rotating.
- p **WARNING! DO NOT** attempt to free a jammed saw blade without first switching off or removing the plug from the mains power supply.
- 7 **DO NOT** cut metals or substances that may produce toxic dust. **Saw must only be used to cut wood or wood derived substances and plastics.**
- 7 **DO NOT** attempt to cut round section wood.
- 7 **DO NOT** use solvent to clean plastic parts, it which may damage them. Use a soft damp cloth only.
- 3 Store blades in a safe, dry childproof location.

2. SPECIFICATION

Motor230V - 1400W	Sawing section at 2 x 45°55 x 35mm
Speed4000rpm	Table	Semi-circular, radius 160mm
Saw bladeØ250 x Ø16 x 2.8mm	Dust extraction port Ø48mm
Sawing section at 90°120 x 60mm	Weight15kg
Sawing section at 45°95 x 35mm		

3. ASSEMBLY

- p **WARNING! ENSURE THAT THE SAW IS NOT CONNECTED TO THE MAINS POWER BEFORE COMMENCING ASSEMBLY.**
- 3.1. Screw the locking handle (fig. 1.9) into the elbow (fig. 1.10).
- 3.2. Push workpiece supports (fig. 1.5) into the mounting holes at either end of the table extensions and secure with clamp screws (fig. 1.7).
- 3.3. Plug the clamping device (fig. 1.11) into one of the two holes (fig.1.6) on the left and right of the base plate.

3.4. Mounting

The saw should be bolted to a sturdy workbench. Ensure that the supporting surface is strong enough to take the weight of the saw and any workpiece. Position the saw in a suitable work area with enough clearance to allow room when working with large workpieces. Ensure that there is adequate lighting and that the saw blade can be clearly seen.

3.5. Extraction

- 3.5.1. Connect the outlet (fig. 1.15) to a suitable extraction system, or attach the dust bag (fig. 1.14).
- p **WARNING!** Wood dust can be harmful to health by inhalation and skin contact and concentrations of small dust particles in the air can form an explosive mixture. Therefore, ensure that there is adequate ventilation and that the saw has the dust bag fitted or is attached to a dust-extraction unit.

4. ADJUSTMENTS

- p **WARNING! ALWAYS DISCONNECT SAW FROM THE MAINS POWER BEFORE MAKING ANY ADJUSTMENTS.**

4.1. Table

- 4.1.1. To adjust the table (fig. 1.4) loosen the locking handle (fig.1.9) approx. two turns and press the latch (fig. 1.8). Table will now rotate.
- 4.1.2. The table will latch at 0°, 15°, 22.5°, 30° and 45°. Once the latch is engaged at the required angle, tighten the locking handle. For any other angle the table is retained by the locking handle only.

4.2. Blade

- 4.2.1. Lightly press down on the handle (fig. 1.1) and at the same time pull the locking pin (fig.1.3). Control the spring-loaded saw arm up until it reaches the fully raised position.
- 4.2.2. The blade can be tilted by up to 45° to the left by loosening the clamp screw (fig. 2.1). The clamp screw must be unscrewed until the blade arm is pulled back slightly on the pivot and becomes free to rotate. Firmly tighten screw to clamp at the required angle.

Initial set-up - before first use set blade angle to 0° on scale and confirm, using a square, that the blade is at 90° to the table. If it is not, loosen lock nut and adjust stop screw (fig. 2.3) to give 90°, retighten lock nut. Similarly, set the blade at 45° and check that the blade to table angle is 45°. Any required adjustment is provided by lock nut and stop screw (fig. 2.2).

4.3. Changing the blade

- 4.3.1. Swing up the blade to full height.
- 4.3.2. Remove the guard link screw (fig.3.1) and pivot the link (fig. 3.5) out of the way.
- 4.3.3. Loosen guard screw (fig. 3.2) and remove second guard screw (fig.3.6). Remove pivoted blade guard (fig. 3.3).
- 4.3.4. Remove the single retaining screw and slide off the dust deflector (fig. 3.4).
- 4.3.5. Use the pin spanner to hold the outer blade flange while removing the blade retaining bolt, by turning it clockwise (LH thread), with the tube spanner. Remove the outer blade flange and then the saw blade with care. Wear hide palm rigger's gloves to protect hands from the blade, which is sharp.
- 4.3.6. When fitting the new blade it is very important to ensure that the direction arrow on the blade matches the arrow on the blade housing.
- 4.3.7. Refit the dust deflector, the pivoted guard and the link. Check the operation of the pivoted guard by lowering and raising the blade.

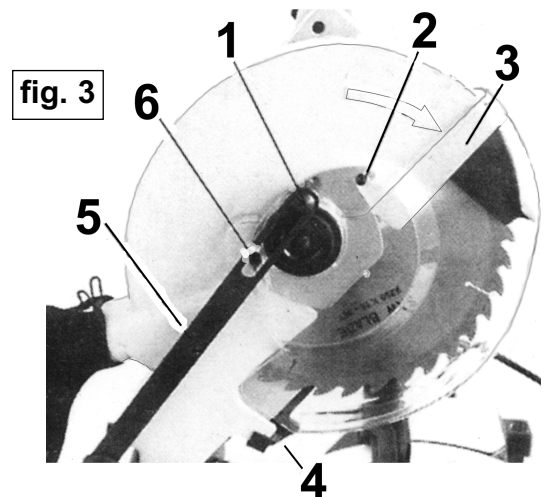
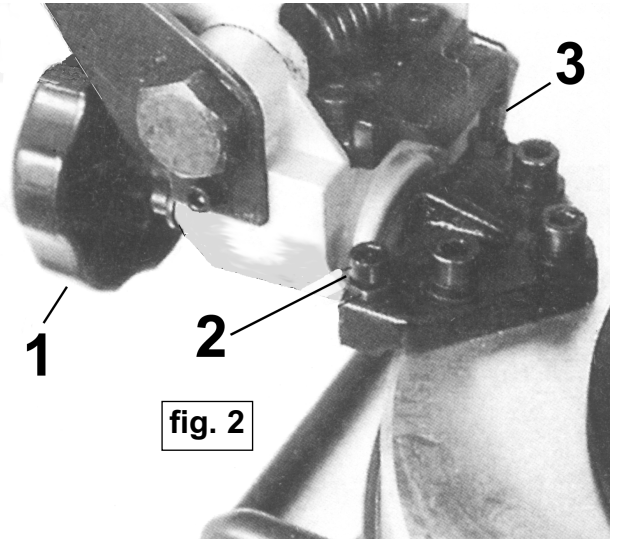
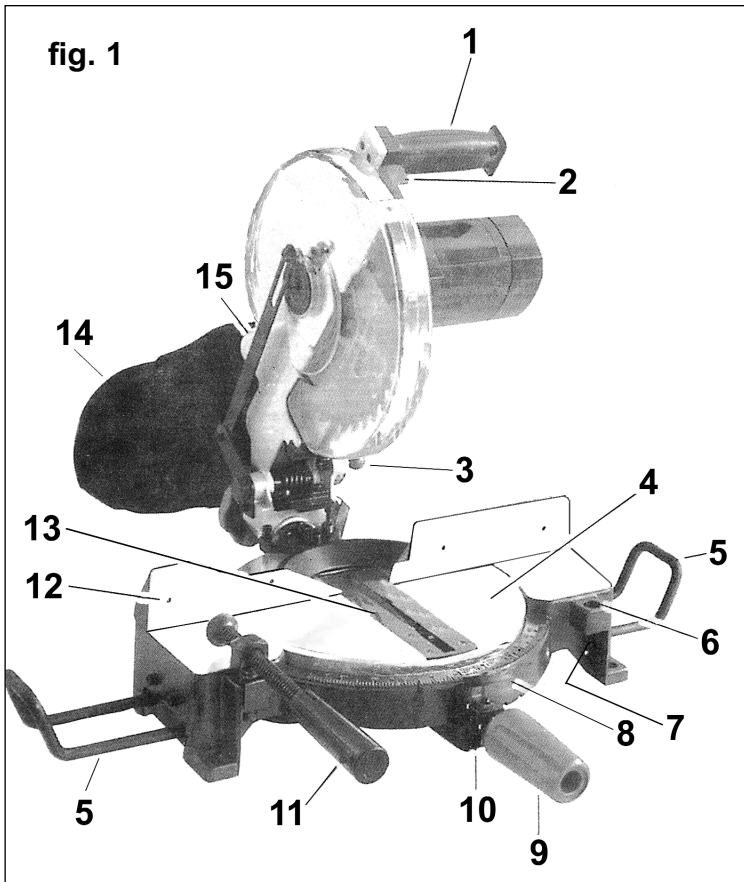

4.4. Table insert

WARNING! To reduce the risk of an accident the table insert (fig. 1.13) must be replaced if it becomes worn or damaged.

- 4.4.1. Raise the blade.
- 4.4.2. Remove the five countersunk screws and remove insert.
- 4.4.3. Fit new insert and retain with the five countersunk screws.

5. OPERATING INSTRUCTIONS

WARNING! As with all power tools, there are potential hazards involved in the use of this saw. It is, therefore, vital to ensure that you have read and understood all the safety instructions in Section 1.

Familiarise yourself again with the specific saw safety rules for each step of the following operation. Failure to do so could cause serious damage and/or personal injury and may invalidate your warranty. Disconnect the saw from the mains power before making any adjustments or removing/fitting the blade. Ensure that all screws and nuts are secure and that the blade is in good condition and correctly fitted. ALWAYS wear approved safety eye protection.

- 5.1. Set the required table angle and blade angle (paras. 4.1. & 4.2.). Leave blade in raised position.
 - 5.2. Secure the workpiece against the fence (fig. 1.12) with the clamp (fig. 1.11).
 - 5.3. **DANGER!** If holding the workpiece by hand take extreme care and ensure hand is kept away from the blade.
 - 5.3. When you have completed the cut, the waste off-cut will either remain on the saw table and workpiece supports or fall off, depending upon size. Before starting, therefore, consider how you will handle the off-cut.
 - 5.4. Plug the saw into the mains power supply.
 - 5.5. Hold the saw handle and squeeze the switch trigger. When the blade has reached maximum speed press the lock lever (fig. 1. 2) and bring the blade down onto the workpiece.
 - 5.6. Slowly move the blade down through the workpiece. Do not try to force the blade through the wood, use light pressure.
 - 5.7. When the cut is complete allow the blade to rise to the upper position and release the switch to turn off the saw.
- WARNING! DO NOT attempt to pick up an off-cut or to remove the clamped workpiece before the saw blade has completely stopped.**

6. MAINTENANCE

- 6.1. Regularly clean the saw to remove dirt, dust and chips using a brush and cloths and re-oil moving parts. If compressed air is used for cleaning remember to wear protective goggles and keep other personnel at a safe distance.
- 6.2. Ensure that motor vents are clear at all times.
- 6.3. Clean plastic components with water and detergent, never use caustic or abrasive cleaners.

7. DECLARATION OF CONFORMITY

Declaration of Conformity We, the sole importer into the UK, declare that the product listed below is in conformity with the following standards and directives.

**10" COMPOUND MITRE SAW
MODEL SM10**

73/23/EEC Low Voltage Directive
89/336/EEC EMC Directive
98/37/EC Machinery Directive
93/68/EEC EC Marking Directive



The construction file for this product is held by the Manufacturer and may be inspected, by a national authority, upon request to Jack Sealey Ltd.

Signed by Mark Sweetman

25th June 2001

For Jack Sealey Ltd. Sole importer into the UK of Sealey Quality Machinery.

NOTE: It is our policy to continually improve products and as such we reserve the right to alter data, specifications and component parts without prior notice.

IMPORTANT: No responsibility is accepted for incorrect use of this equipment.

WARRANTY: Guarantee is 12 months from purchase date, proof of which will be required for any claim.

INFORMATION: For a copy of our latest catalogue and promotions call us on 01284 757525 and leave your name and address, including postcode.



**Sole UK Distributor,
Sealey Group,
Bury St. Edmunds, Suffolk.**



01284 757500



01284 703534

E-mail: sales@sealey.co.uk