

Thank you for purchasing a Sealey product. Manufactured to a high standard this product will, if used according to these instructions and properly maintained, give you years of trouble free performance.



IMPORTANT: PLEASE READ THESE INSTRUCTIONS CAREFULLY. NOTE THE SAFE OPERATIONAL REQUIREMENTS, WARNINGS AND CAUTIONS. USE THIS PRODUCT CORRECTLY AND WITH CARE FOR THE PURPOSE FOR WHICH IT IS INTENDED. FAILURE TO DO SO MAY CAUSE DAMAGE AND/OR PERSONAL INJURY AND WILL INVALIDATE THE WARRANTY. RETAIN THESE INSTRUCTIONS FOR FUTURE USE.

1. SAFETY INSTRUCTIONS

1.1 ELECTRICAL SAFETY

WARNING! It is the responsibility of the owner and the operator to read, understand and comply with the following:

You must check all electrical products, before use, to ensure that they are safe. You must inspect power cables, plugs, sockets and any other connectors for wear or damage. You must ensure that the risk of electric shock is minimised by the installation of appropriate safety devices. A Residual Current Circuit Breaker (RCCB) should be incorporated in the main distribution board. We also recommend that a Residual Current Device (RCD) is used. It is particularly important to use an RCD with portable products that are plugged into a supply which is not protected by an RCCB. If in any doubt consult a qualified electrician. You may obtain a Residual Current Device by contacting your Sealey dealer.

You must also read and understand the following instructions concerning electrical safety.

- 1.1.1 The **Electricity at Work Act 1989** requires that all portable electrical appliances, if used on business premises, are tested by a qualified electrician, using a Portable Appliance Tester (PAT), at least once a year.
- 1.1.2 The **Health & Safety at Work Act 1974** makes owners of electrical appliances responsible for the safe condition of those appliances and the safety of the appliance operators. **If in any doubt about electrical safety, contact a qualified electrician.**
- 1.1.3 Ensure that the insulation on all cables and on the appliance is safe before connecting it to the power supply. See 1.1.1. and 1.1.2. and use a Portable Appliance Tester.
- 1.1.4 Ensure that cables are always protected against short circuit and overload.
- 1.1.5 Regularly inspect power supply cables and plugs for wear or damage and check all connections to ensure that none are loose.
- 1.1.6 **Important:** Ensure that the voltage marked on the appliance matches the power supply to be used and that the plug is fitted with the correct fuse - see fuse rating at right.
- 1.1.7 **DO NOT** pull or carry the appliance by the power cable.
- 1.1.8 **DO NOT** pull the plug from the socket by the cable.
- 1.1.9 **DO NOT** use worn or damaged cables, plugs or connectors. Immediately have any faulty item repaired or replaced by a qualified electrician. When a BS 1363/A UK 3 pin plug is damaged, cut the cable just above the plug and **dispose of the plug safely.**

Fit a new plug according to the following instructions (UK only).

a) Connect the GREEN/YELLOW earth wire to the earth terminal 'E'.

b) Connect the BROWN live wire to the live terminal 'L'.

c) Connect the BLUE neutral wire to the neutral terminal 'N'.

d) After wiring, check that there are no bare wires, that all wires have been correctly connected, that the cable outer insulation extends beyond the cable restraint and that the restraint is tight.

Double insulated products, which are always marked with this symbol , are fitted with live (brown) and neutral (blue) wires only.

To rewire, connect the wires as indicated above - **DO NOT** connect either wire to the earth terminal.

- 1.1.10 Products which require more than 13 amps are supplied without a plug. In this case you must contact a qualified electrician to ensure that a suitably rated supply is available. We recommend that you discuss the installation of an industrial round pin plug and socket with your electrician.
- 1.1.11 If an extension reel is used it should be fully unwound before connection. A reel with an RCD fitted is preferred since any appliance plugged into it will be protected. The cable core section is important and should be at least 1.5mm², but to be absolutely sure that the capacity of the reel is suitable for this product and for others which may be used in the other output sockets, we recommend the use of 2.5mm² section cable.

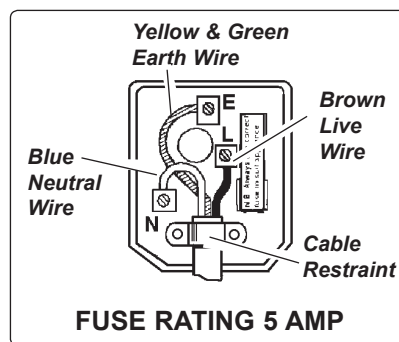

1.2 GENERAL SAFETY

- ✓ Disconnect the jig saw from the mains power before changing accessories, servicing or performing any maintenance.
- ✓ Keep saw in good condition. Check moving parts and alignment, and keep saw blades sharp. If necessary use an authorised service agent.
- ✓ Replace or repair damaged parts. *Use recommended parts only. Unauthorised parts may be dangerous and will invalidate the warranty.*
- ✓ Keep the jig saw clean for best and safest performance.
- ✓ Wear approved safety eye protection with side shields, and a dust mask if jig saw generates dust.
- ✓ Remove ill fitting clothing. Remove ties, watches, rings, other loose jewellery and contain long hair.
- ✓ Use the jig saw in a suitable working area, keep area clean and tidy and free from unrelated materials, and ensure there is adequate lighting.
- ✓ Use the correct type of blade for the task, such as cutting wood, resin board, ceramic tiles, plastics, copper tubing and thin metal sheeting.
- ✓ Prevent body contact with grounded surfaces to avoid electric shock i.e. pipes, radiators, ranges, refrigerators etc.
- ✓ Evaluate your working area before using the jig saw i.e. floors and enclosures may contain hidden electrical wires or water piping.
- ✓ Maintain correct balance and footing. **DO NOT** over-reach and ensure the floor is not slippery and wear non skid shoes.
- ✓ Keep children and unauthorised persons away from the working area.
- ✓ Secure non stable work piece with a clamp, vice or other adequate holding device.
- ✓ Avoid unintentional starting, and ensure the lock on button is disengaged before use.
- ✓ Ensure the power cable is kept to the rear of the saw.
- ✗ **DO NOT** force jig saw but allow the saw to progress normally. Force may break the blade.
- ✗ **DO NOT** secure the saw in a clamp or vice.
- ✗ **DO NOT** use the saw without it's front guard down and before you have checked blade is secured.
- ✗ **DO NOT** touch the blade and **DO NOT** point the blade at yourself and/or others.
- ✗ **DO NOT** operate jig saw where there are flammable liquids or gasses.
- ✗ **DO NOT** get the jig saw wet or use in damp or wet locations.
- ✗ **DO NOT** hold unsecured work in your hand.
- ✗ **DO NOT** turn the saw on whilst the blade is in a workpiece.
- ▲ **DANGER! DO NOT** shine laser beam into your or anybody elses eyes.

- X **DO NOT** leave the jig saw running whilst laying on it's side or if unattended.
- X **DO NOT** operate jig saw if any parts are missing or if saw and/or blade is damaged as this may cause failure and/or possible personal injury.
- X **DO NOT** operate jig saw when you are tired, under the influence of alcohol, drugs or intoxicating medication.
- X **DO NOT** carry the jig saw with your finger on the power switch.
- ✓ When not in use switch jig saw off, remove plug from power supply and store in a safe, dry, childproof area.

Risk of Hand Arm Vibration Injury.

The SJS700.V2 Jigsaw Variable Speed 750W, when operated in accordance with these instructions and tested in accordance with EN 28662-1: 1993 results in the following vibration emission declared in accordance with BS EN12096: 1996.

Measured vibration emission value (Wood): . . . 7.6m/s² Uncertainty: 3.04m/s²
 Measured vibration emission value (Metal): . . 11.2m/s² Uncertainty: 4.48m/s²

These values are suitable for comparison with emission levels of other tools that have been subject to the same test.

This tool may cause hand-arm vibration syndrome if its use is inadequately managed.

Recommended Measures to reduce risk of hand-arm vibration syndrome:

For Wood this tool should not be used by an individual regularly for more than 106 minutes in any 8 hour period.

For Metal this tool should not be used by an individual regularly for more than 48 minutes in any 8 hour period.

This duration of use should be reduced if the individual is exposed to hand-arm vibration from other sources.

2. SPECIFICATION & DESCRIPTION

Heavy-duty 750Watt electric motor with variable speed control. Features laser guide for accurate cutting. Pendulum cutting action with a maximum capacity cut of 100mm in wood. Tilting sole-plate allows cutting of bevels up to 45°. Supplied with width cutting gauge, dust extraction outlet and fitted with 2mtr cable and BS approved plug.

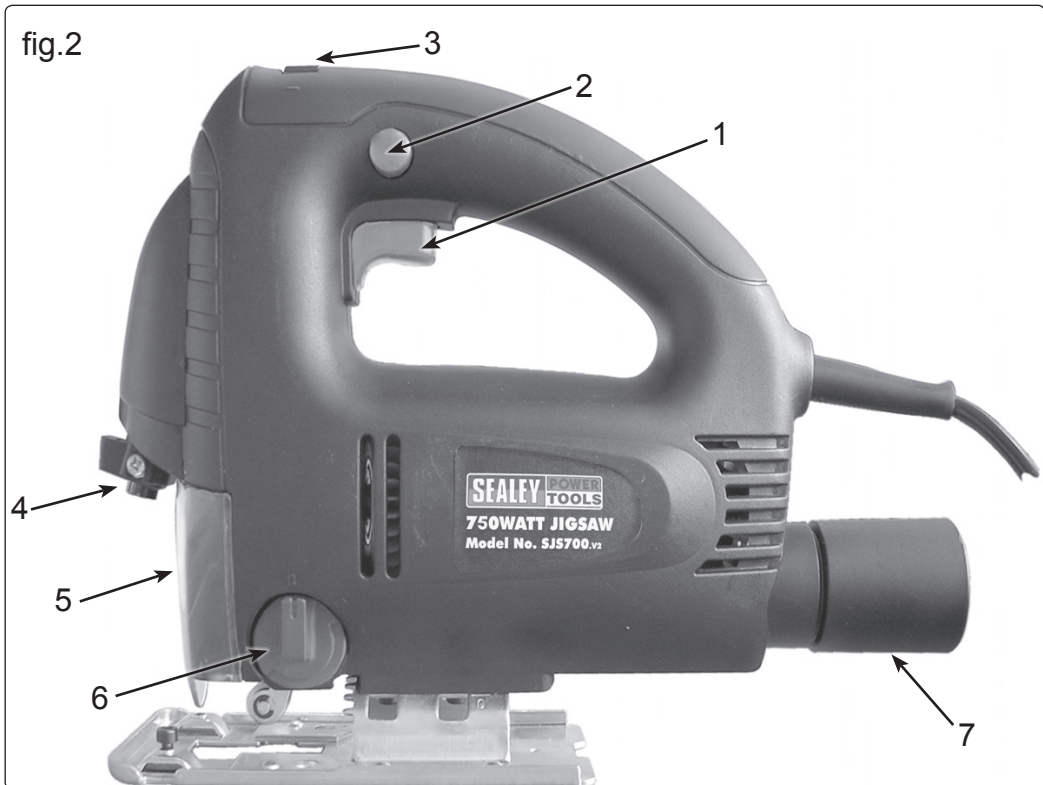

SPECIFICATION

Length of stroke 27mm
 Cutting capacity wood 100mm
 Cutting capacity plastic. . . . 20mm
 Cutting capacity steel 10mm
 Power input 230V 750Watt
 Stroke per minute 500~3000

Net weight 2.48Kg
 Sound pressure level 96.3dB(A)
 Sound power level 85.3dB(A)
 Vibration Wood 7.6m/s²
 Vibration Metal 11.2m/s²
 Mitre Cuts ± 45°

3. OPERATING INSTRUCTIONS

- WARNING!** Ensure the jigsaw is switched off and unplugged from the mains power supply. **DO NOT** use blunt or damaged blades, and use the correct blade for the material to be cut.

3.1 Fitting the saw blade.

- 3.1.1 Take the hex key and loosen the two hex screws (fig.1.1) in the saw head (do not remove screws).
- 3.1.2 Insert the saw blade into the centre slot of the saw head as far as it will go. Ensure the teeth face forwards.
- 3.1.3 Tighten hex screws and check that the back of the saw blade is in the groove of the roller guide (fig.3.2).

- WARNING! BEFORE USE ENSURE ALL SAFETY INSTRUCTIONS IN CHAPTER 1 ARE STRICTLY FOLLOWED.**

3.2 ON/OFF Switch.

- 3.2.1 Start and stop your jigsaw by depressing and releasing the ON/OFF "trigger" switch (fig.2.1).
- 3.2.2 To lock the switch in the "ON" mode depress the ON/OFF switch and the lock button (fig.2.2) at the same time, then release the lock button.
- 3.2.3 To release the lock depress the on/off switch again and the saw will stop.

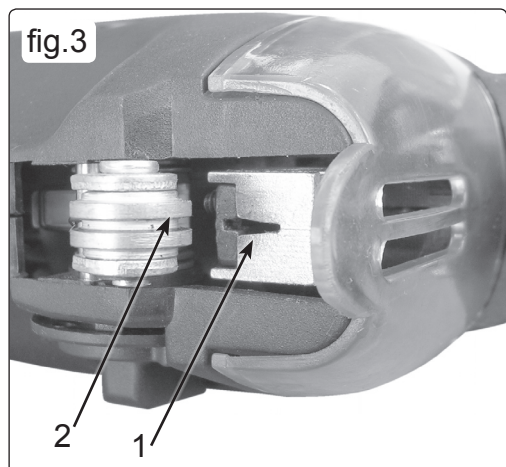

3.3 Speed setting.

A variable speed switch is located in the handle (fig.2.3). Switch setting 1 is the lowest speed and setting 6 is the highest.

3.4 Cutting: Maximum thickness: Wood 100mm; Metal 10mm

3.4.1 General cutting.

- Select the correct blade for the material.
- Check that the base plate is at 90° to the saw blade.
- Switch on the laser guide (fig.1.2) and maintain the laser beam on the scribed line on the workpiece throughout the cutting process.

Note: Use a light cutting oil for metals where necessary.

3.4.2 Arc cutting.

To cut small circles or arcs, reduce the speed by using the variable speed switch.

3.4.3 Centre cutting.

Drill a pilot hole large enough for the blade of the jigsaw into the centre of the hole to be cut.

3.4.4 Mitre (angle) cutting.

Loosen the two hex screws underneath the base plate (fig.4.1). Slide the base plate towards the back of the saw and then twist the base to the required angle using the scale marked on the plate and then slide the base forward to locate and then re-tighten the hex screws. Ensure work is adequately clamped, especially when cutting at a 45° angle.

▲ **DANGER! Ensure the jigsaw is switched off and unplugged from the mains before adjusting base plate.**

3.5 Pendulum cutting (fig.5).

Pendulum cutting is performed by adjusting the pendulum switch. This option will allow the blade to swing, resulting in improved cutting and the use of a higher speed for certain materials.

- When the pendulum selector is set at "0" the pendulum mechanism is off, the blade will operate in a rigid up and down movement.
- To engage the pendulum option, turn switch to number "1". To increase the amount of swing, progress to number "2".

3.6 Using the graduated guide (fig.6).

3.6.1 The graduated guide allows a cut to be made parallel to a given edge of the workpiece, thereby ensuring a straight, accurate cut.

3.6.2 Slide the graduated rule into the base and position as desired.

Tighten the fixing screws to ensure guide does not slip/move out of position.

3.6.3 Execute cut, ensuring the flat plate of the guide remains in contact with the edge of the workpiece.

3.7 Dust / chip extraction.

3.7.1 This jigsaw is equipped with a dust/chip extractor outlet which can be connected to any vacuum cleaner.

3.7.2 Mount the adaptor on the jigsaw and fix it in place by twisting anti-clockwise (fig.2.7).

3.7.3 Attach the hose of your vacuum cleaner to the adaptor. Note: Should you require a special adaptor, please contact the manufacturer of your vacuum cleaner.

3.8 Laser Guide Adjustment.

3.8.1 Switch on the laser guide and check the alignment of the beam, the beam should run parallel to the centre line of the jigsaw, if adjustment is required, slacken screw fig.7C and rotate laser fig.7D until the beam is parallel to the centre line, tighten screw C.

3.8.2 To adjust the vertical alignment (fig.8) place the jigsaw centrally on a marked line along its length. Depending to the direction of the adjustment slacken the screw fig.7A or 7B and tighten the opposite side to move the beam until it is central with the centre line marked underneath the jigsaw.

☐ **DANGER! DO NOT shine laser beam into your own or anybody else's eyes.**

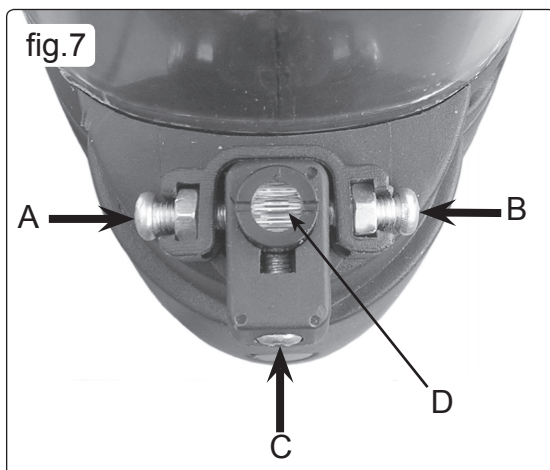
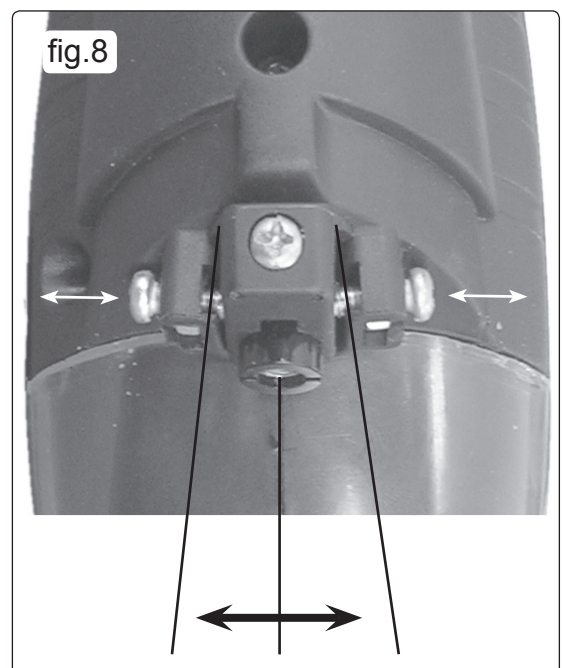
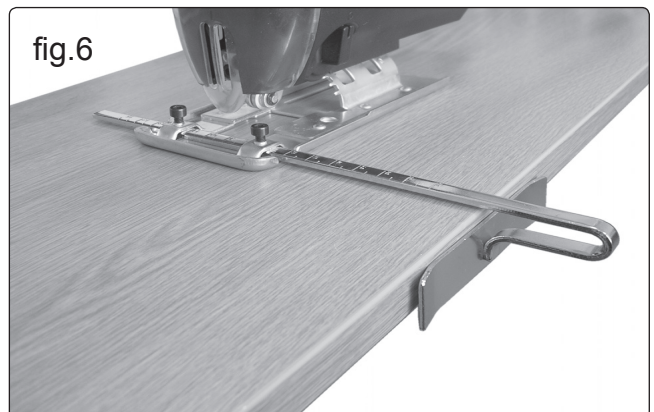
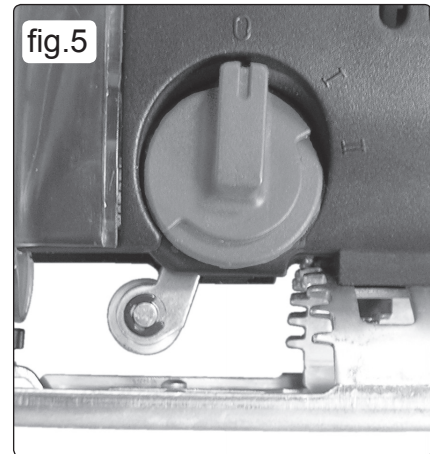
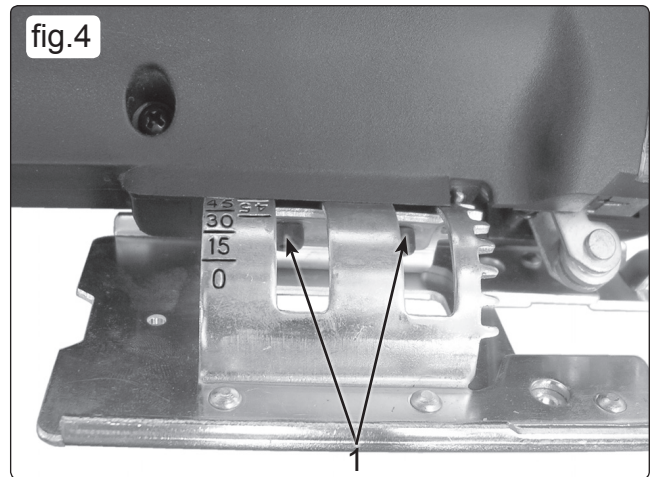

4. MAINTENANCE.

WARNING! *Ensure the jig saw is switched off and unplugged from the mains.*

4.1 Cleaning

Keep the jigsaw ventilation slots clean and free from obstructions. If available blow compressed air into vents to clear any internal dust (safety goggles must be worn when undertaking this process). Keep the outer case of the saw clean and free from grease. **DO NOT** wash with water or use solvents or abrasives, use a damp cloth.

4.2 Saw Blade

Check blades to ensure they are sharp and not damaged or bent. **DO NOT** use blunt or damaged blades.

NOTE: It is our policy to continually improve products and as such we reserve the right to alter data, specifications and component parts without prior notice.

IMPORTANT: No liability is accepted for incorrect use of this product.

WARRANTY: Guarantee is 12 months from purchase date, proof of which will be required for any claim.

INFORMATION: For a copy of our latest catalogue and promotions call us on 01284 757525 and leave your full name and address, including postcode.



Sole UK Distributor, Sealey Group,
Kempson Way, Suffolk Business Park,
Bury St. Edmunds, Suffolk,
IP32 7AR



01284 757500



www.sealey.co.uk



01284 703534



sales@sealey.co.uk