

SEALEY POWER WELDERS

INSTRUCTIONS FOR: GAS WELDING/CUTTING KIT MODEL: SGA1.V2

Thank you for purchasing a Sealey product. Manufactured to a high standard this product will, if used according to these instructions and properly maintained, give you years of trouble free performance.



IMPORTANT: PLEASE READ THESE INSTRUCTIONS CAREFULLY. NOTE THE SAFE OPERATIONAL REQUIREMENTS, WARNINGS AND CAUTIONS. USE THE PRODUCT CORRECTLY AND WITH CARE FOR THE PURPOSE FOR WHICH IT IS INTENDED. FAILURE TO DO SO MAY CAUSE DAMAGE AND/OR PERSONAL INJURY AND WILL INVALIDATE THE WARRANTY. PLEASE KEEP INSTRUCTIONS SAFE FOR FUTURE USE.

1. SAFETY INSTRUCTIONS

- ✓ Always have a fire extinguisher nearby.
- x Never use oxygen or fuel gas to blow soot or dirt from your clothes.
- x **DO NOT** wear ragged clothes, as sparks can ignite the ragged or loose ends.
- ✓ Always wear goggles or a helmet with the appropriate shade lens.
- x **DO NOT** use shaded safety spectacles or unshaded face shield visors for cutting or welding. They **DO NOT** stop the harmful rays which cause eye damage.
- ✓ Use gauntlet type gloves made from heat resistant material.
- ✓ Secure cylinders to a trolley, wall or post to prevent them from falling.
- ✓ All cylinders should be used and stored in an upright position.
- x Never drop or strike a cylinder. **DO NOT** use cylinders that have been dented.
- ✓ Cylinder caps should be used when storing or moving cylinders.
- ✓ Empty cylinders should be kept in specified areas and clearly marked 'EMPTY'.
- x Never use oil or grease on any inlet connections, outlet connections or cylinder valves.
- ✓ Examine hoses for cuts, burns or worn areas before each use. Also inspect fittings for damage. If any damage is found, replace immediately.
- x **DO NOT** repair hose with tape.
- ✓ Always use reverse flow check valves on torch and flashback arrestors on the regulator. This greatly reduces the possibility of mixing gases in the regulator or hoses. Reverse flow check valves are an important safety precaution.
- ✓ Working pressure on the acetylene regulator should **NEVER** be set above 15psi (1 bar).
- ✓ Keep all threads and unions clean and free from oil, dirt or grease.
- x Never apply oil or grease to any thread.
- ✓ **These instructions cover the use of the kit on mild steel. If used on any other materials, extra precautions will have to be taken.**
- ✓ Make sure that there is a good flow of air to the user and the tip, at all times. Use a welding fume extractor if conditions are poor or space is confined.
- x Never leave the gun alight and unattended.
- ✓ For safety advice regarding gas bottles (oxygen and acetylene) refer to the supplier of the bottles.
- ✓ Make sure bottle keys are in place at all times so that in the event of an emergency the valves can be turned off quickly.
- ✓ Keep hoses away from flame at all times. Make sure that hoses are laid flat where possible and not in a position where they can be run over by vehicles, which would result in permanent damage.
- ✓ **LEAKING HOSES CAN KILL.** Leak test all connections and valves prior to each use of the equipment.
- ✓ If hoses are not long enough, join them together with the manufacturer's couplings only.
- x **DO NOT** join damaged hoses, they must be replaced immediately.
- ✓ Remember at all times **BLUE = OXYGEN 'O'**
RED = ACETYLENE 'A'
- ✓ At no time may you interchange parts contained in this kit with those of other manufacturers.
Only Sealey replacement items should be used.
- ✓ Acetylene fittings have a left-handed thread and notches on hose unions to indicate this.
- ✓ The regulators in this kit have no user-serviceable parts. All repairs/calibrations must only be undertaken by a BCGA approved service agent.

2. CONTENTS

Contents

- 1) Torch Handle
- 2) Hose Check Valve, OXYGEN (normal R.H. thread)
- 3) Hose Check Valve, ACETYLENE (reverse L.H. thread)
- 4) Cutting Attachment
- 5) Cutting Nozzle 1/32"
- 6) Cutting Nozzle 3/64"
- 7) Cutting Nozzle 1/16"
- 8) Nozzle Cleaning Tools
- 9) Mixer Nozzle
- 10) Welding Nozzles No. 2, No. 5, No. 10
- 11) Spark Lighter
- 12) Regulator OXYGEN Twin Gauge Single Stage (BLUE code)
- 13) Flash Arrestor OXYGEN (BLUE code)
- 14) Regulator ACETYLENE Twin Gauge Single Stage (RED code)
- 15) Flash Arrestor ACETYLENE (RED code)
- 16) Hoses, 2, 3/8" x 1.5mtr, complete with fittings
(These are stored in the lid, not shown here)

fig.1

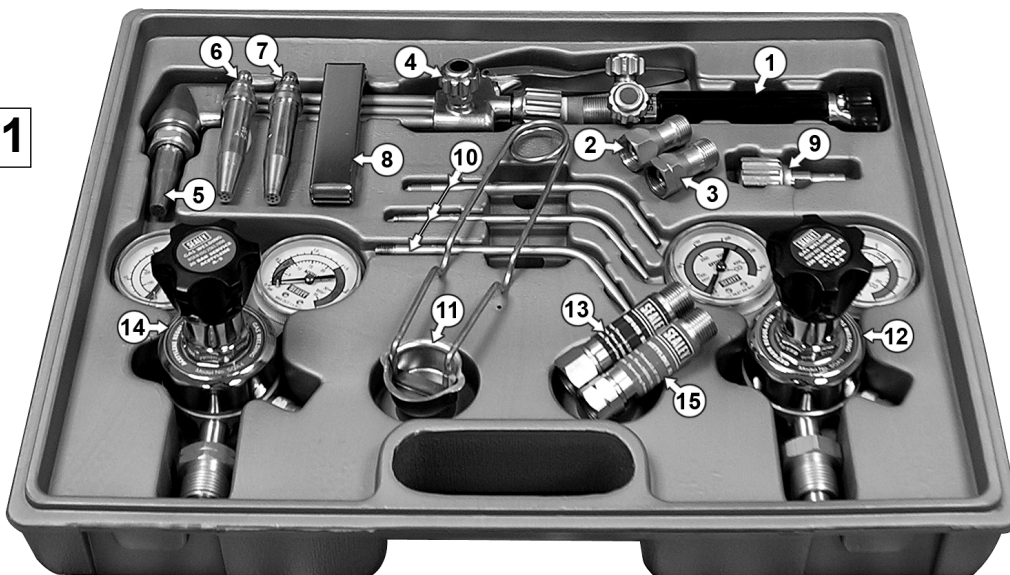

3. ASSEMBLY

❑ **WARNING! DANGER OF EXPLOSION.** All parts which come into contact with acetylene or oxygen, including hands and tools, must be free from oil or grease. If grease or oil is found on a cylinder, discontinue its use immediately and contact your gas supplier.

- 3.1. **Preparing the cylinder.** Make sure that the cylinder to be used is safe and properly secured as noted in the safety precautions.
- 3.1.2 Whilst standing on one side 'crack' each cylinder valve. 'Cracking' is to quickly open and close the valve allowing gas to escape and clear the valve of any foreign bodies.

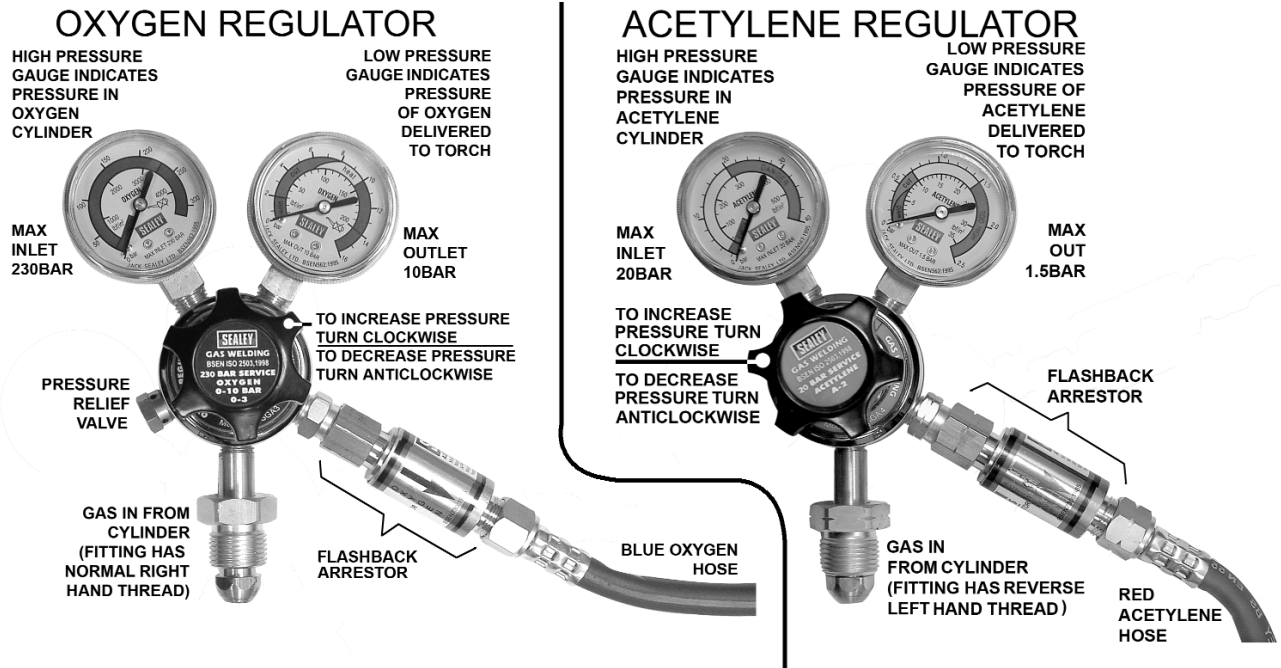

3.2 CONNECTING THE GAS REGULATORS TO THE CYLINDERS.

NOTE: PRESSURE REGULATORS SHOULD BE TREATED AS PRECISION INSTRUMENTS AND SHOULD NOT BE JARRED OR KNOCKED.

- 3.2.1 **Function of the regulators.** Fitted to the outlets of the gas cylinder valves, the pressure regulators reduce the pressure of the gas from cylinder pressure to the constant lower pressure required for the operation of the equipment. The left hand gauge indicates the pressure in the cylinder. The right hand gauge indicates the pressure of the gas being delivered to the torch. Pressure reduction within the regulator occurs in two stages.
- 3.2.2 Attach oxygen and acetylene regulators to the appropriate cylinders. On each gauge ensure the inlet filter is in place and is not blocked or contaminated. If an 'O' ring is fitted to the inlet, check for damage and replace if necessary with an 'O' ring recommended by the regulator manufacturer. **Do not use any form of jointing paste or tape between regulators and cylinder valves.** Before attaching the gauges wipe the fittings with a clean dry cloth. Screw the union at the base of each regulator to the appropriate cylinder by hand. Ensure that the gauge is correctly orientated so as to be seen properly by the operator in use. To tighten, turn **CLOCKWISE** for OXYGEN, and **ANTI-CLOCKWISE** for ACETYLENE. A wrench should be used to ensure tight connections.
- 3.2.3 Close the regulators by turning the adjusting screws anti-clockwise to relieve the pressure on the diaphragm before opening the cylinder valve. If this is not done, pressure from the cylinder can damage the diaphragm and render the regulator inoperative.
- 3.2.4 The cylinder valve-to-regulator connection should be checked for leaks using an approved leak detection spray or soap and water solution.

3.3 CONNECTING THE FLASH ARRESTORS AND HOSES TO THE GAS REGULATORS.

- 3.3.1 Connect the BLUE, OXYGEN flash arrestor to the outlet on the OXYGEN regulator. (As shown above, on the left).
- 3.3.2 Then, connect the BLUE hose to the BLUE, OXYGEN flash arrestor. (As shown above, on the left).
- 3.3.3 Connect the RED, ACETYLENE Flash arrestor to the outlet on the ACETYLENE regulator. (As shown above, on the right).
- 3.3.4 Then, connect the RED hose to the RED, ACETYLENE flash arrestor. (As shown above, on the right).
- 3.3.5 Tighten all nuts securely with a wrench. If any sign of oil or grease is found on the flash arrestors or regulators discontinue use immediately.

Note: New hoses contain a preservative powder which must be blown out before use.

- 3.3.6 Prior to attaching the torch, blow out both hoses to eliminate any particles or debris. Perform this on one hose at a time and in a well ventilated area, otherwise you may create conditions for fire or explosion.
 - a. Turn the oxygen or acetylene regulator adjusting screw clockwise to allow 5psi to pass through hose.
 - b. Allow oxygen or acetylene to flow for approximately 10 seconds to purge each hose in turn.

3.4 ASSEMBLING THE TORCH FOR WELDING.

- ❑ **WARNING!** The teflon seal on the welding attachment inlet must not be damaged or missing, otherwise gases will mix inside the torch and result in flashbacks or backfires. Always inspect the seal, coupling nut and torch head for damage or oil. If either is found, discontinue use and contact your supplier.
- 3.4.1 Screw the chosen welding nozzle into the welding attachment making sure that it is fully tightened down.
 - 3.4.2 Screw the welding attachment with nozzle attached onto the torch handle as shown below. Before fully tightening the ribbed nut, check that the orientation of the gas valve knobs suits your normal welding practice. Adjust if necessary and fully tighten the ribbed nut.

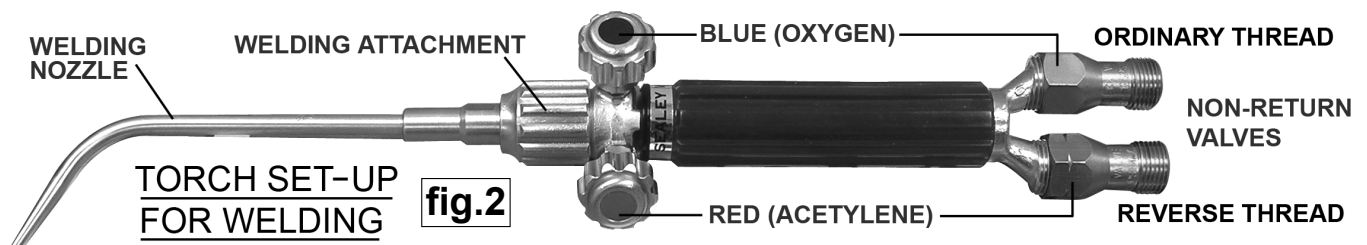

3.5 ASSEMBLING THE TORCH FOR CUTTING.

- **WARNING!** The teflon seal on the cutting attachment inlet must not be damaged or missing, otherwise gases will mix inside the torch and result in flashbacks or backfires. Always inspect the seal, coupling nut and torch head for damage or oil. If either is found, discontinue use and contact your supplier.
- 3.5.1 To change the cutting nozzle loosen and remove the nut which holds it in place and withdraw the nozzle. Slide the chosen cutting nozzle through the nut and screw the assembly into the cutting attachment and fully tighten down.
- 3.5.2 Screw the cutting attachment with nozzle attached onto the torch handle as shown below. Before fully tightening the the ribbed nut, adjust the orientation of the gas valve knobs so that they do not block the movement of the lever (B).

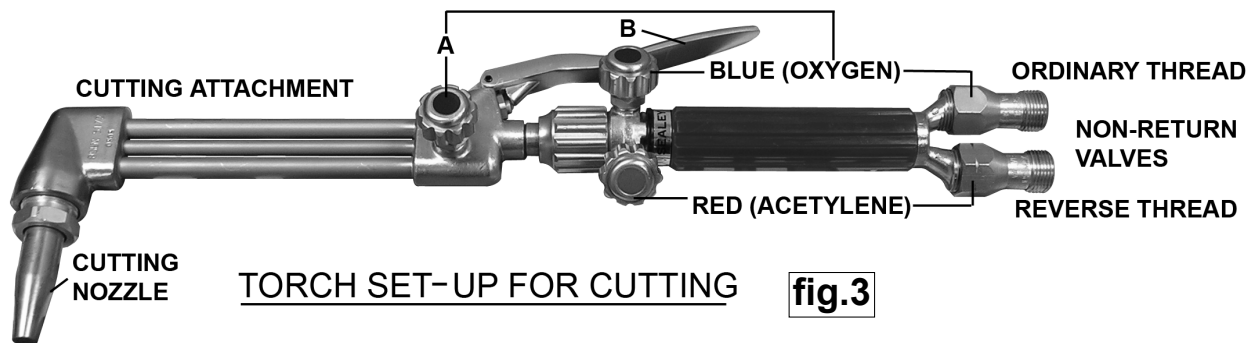

3.6 CONNECTING THE NON-RETURN VALVES AND HOSES TO THE TORCH.

- 3.6.1 Always fit the non-return valves provided to the torch before connecting the respective hoses. The non-return valves provided have different direction threads to ensure that they are fitted to the correct side of the torch. The OXYGEN non-return valve has a normal thread and will fit to the blue coded side of the torch (See colour coding on valve knobs). The ACETYLENE non-return valve has a reverse thread and will fit to the red coded side of the torch (See colour coding on valve knobs).
- 3.6.2 Connect the two hoses to the respective non-return valves fitted to the torch handle.
- **WARNING!** If traces of oil or grease are found, **DO NOT** use. Contact your gas supplier immediately.

4. WELDING OPERATION

□ **IMPORTANT! LEAK TEST ALL CONNECTIONS AND VALVES PRIOR TO EACH USE OF THE EQUIPMENT.**

Note: These instructions are intended to describe the facilities and operation of the welding/cutting torch. They are not intended to teach you how to weld or cut using oxyacetylene. If you have no experience of welding/cutting using oxyacetylene it is essential that you seek training from a qualified person or approved training organisation.

- 4.1 Assemble the torch for welding as described in section 3.4 (See also fig.2)
- 4.2 **SETTING THE GAS REGULATOR PRESSURES** Close the regulators by turning the adjusting screws anti-clockwise to relieve the pressure on the diaphragm before opening the cylinder valves. Slowly open the cylinder valve on the oxygen and acetylene bottles in turn. As you do so the high pressure gauge (left hand) on each regulator will register the pressure in the cylinder to which it is attached.
- 4.2.1 Slowly open each regulator in turn by turning the adjusting knob clockwise. As you do so the outlet pressure gauge (right hand) on each regulator will register the outlet pressure of gas being fed to the torch. Adjust the pressure according to the size of nozzle in use and the thickness of the material to be cut or welded. Refer to section 7.2 in the chart overleaf.
- **WARNING!** Never set acetylene regulator at a delivery pressure above 15psi (1 bar).
- 4.2.2 After adjusting the regulators to the desired operating pressures check connections for leaks using an approved leak detection solution. Check for leaks at all connections. If a leak is found, tighten fitting more securely. If leak persists, discontinue use and call your supplier.
- 4.2.3 Briefly open and close the oxygen valve on the torch handle to check that the gas is flowing.
- 4.2.4 Similarly open and close the acetylene valve on the torch handle to check that the gas is flowing.
- **WARNING!** Always use welding gloves and suitable eye protection when welding or cutting. Contact your local Sealey dealer for a full range of protective equipment.
- 4.3 **LIGHTING THE TORCH** Ensure that the gas hoses will not be in the way of the torch when ignited. Ensure that the torch is facing away from you before lighting.
- 4.3.1 Holding the torch in one hand and the striker in the other open the acetylene valve a 1/4 turn (the valve knob is colour coded red). Operate the striker close to the tip to light the acetylene.
- 4.3.2 The first flame that appears will be an orange/yellow colour giving off a small amount of black smoke from its tip. If too much acetylene is flowing the flame will be standing away from the tip of the torch making a roaring noise. In extreme cases this type of flame can blow itself out. To correct such a flame reduce the amount of acetylene until the flame is 8 to 10 inches long with less black smoke.
- 4.3.3 Once the acetylene flame is set correctly begin to introduce oxygen by slowly opening the oxygen control valve on the torch (The valve knob is colour coded blue). The flame will change to a whitish colour and the black smoke will disappear. This flame is not hot enough for welding.
- 4.3.4 Add more oxygen to the flame by further opening the control knob until a brilliant neutral flame is achieved.
- 4.4 **SHUTTING DOWN AND LEAVING SAFE** Turn off the acetylene valve on the torch **first** and then turn off the oxygen valve a few moments later. **Note: Turning the gases off in the wrong order can cause damage to the torch.**
- 4.4.1 Close both cylinder valves.
- 4.4.2 Drain gas from oxygen regulator by opening the oxygen valve on the torch handle. Similarly drain gas from the acetylene regulator.
- 4.4.3 Release the adjusting knobs on the regulators. This is done by turning them anti-clockwise.

5. CUTTING OPERATION

□ **IMPORTANT! LEAK TEST ALL CONNECTIONS AND VALVES PRIOR TO EACH USE OF THE EQUIPMENT.**

Note: These instructions are intended to describe the facilities and operation of the welding/cutting torch. They are not intended to teach you how to weld or cut using oxyacetylene. If you have no experience of welding/cutting using oxyacetylene it is essential that you seek training from a qualified person or approved training organisation.

- 5.1 Assemble the torch for cutting as described in section 3.3 (See also fig.3)
- 5.2 **GAS CONTROL WHEN USING THE CUTTING SET-UP**
The control of the oxygen and acetylene flows on the cutting set-up differs from the welding set-up in the following ways:
 - 5.2.1 The oxygen control valve on the torch handle should be fully opened so that regulation of the oxygen flow takes place using only the oxygen control valve on the cutting attachment (see fig.3A).
 - 5.2.2 The flow of the acetylene is still controlled by the red coded knob on the torch handle.
 - 5.2.3 The flame is then set up using these two control valves only.
 - 5.2.4 Once the flame is set additional oxygen can be introduced into the centre of the flame to initiate the cutting process by operating the oxygen control lever (see fig.3B) mounted on the cutting attachment.

- 5.3 SETTING THE GAS REGULATOR PRESSURES** Close the regulators by turning the adjusting screws anti-clockwise to relieve the pressure on the diaphragm before opening the cylinder valves. Slowly open the cylinder valve on the oxygen and acetylene bottles in turn. As you do so the high pressure gauge (left hand) on each regulator will register the pressure in the cylinder to which it is attached.
- 5.3.1 Slowly open each regulator in turn by turning the adjusting knob clockwise. As you do so the outlet pressure gauge (right hand) on each regulator will register the outlet pressure of gas being fed to the torch. Adjust the pressure according to the size of nozzle in use and the thickness of the material to be cut or welded. Refer to the chart in section 7.1.
- WARNING!** Never set acetylene regulator at a delivery pressure above 15psi (1 bar).
- 5.3.2 After adjusting the regulators to the desired operating pressures check connections for leaks using an approved leak detection solution. Check for leaks at all connections. If a leak is found, tighten fitting more securely. If leak persists, discontinue use and call your supplier.
- 5.3.3 Briefly open and close the acetylene valve on the torch handle to check that the gas is flowing.
- 5.3.4 Ensure that the oxygen control valve on the cutting attachment is closed.
- 5.3.5 Fully open the oxygen control valve on the torch handle.
- 5.3.6 Briefly open and close the oxygen control valve on the cutting attachment to check that the gas is flowing.
- 5.3.7 Briefly operate the oxygen control lever on the cutting attachment to check that the gas is flowing from the centre of the cutting nozzle.
- WARNING!** Always use welding gloves and suitable eye protection when welding or cutting. Contact your local Sealey dealer for a full range of protective equipment.
- 5.4 LIGHTING THE TORCH** Ensure that the gas hoses will not be in the way of the torch when ignited. Ensure that the torch is facing away from you before lighting.
- 5.4.1 Holding the torch in one hand and the striker in the other open the acetylene valve on the torch handle a 1/4 turn (the valve knob is colour coded red). Operate the striker close to the tip to light the acetylene.
- 5.4.2 The cutting tip has six separate holes in it arranged radially and each of these holes will have a small flame coming from it. Develop the correct flame at each hole by alternately increasing the flow of acetylene and then oxygen until a neutral flame is achieved at each hole having a white cone about an 1/8" long.
- 5.5 USING THE OXYGEN CONTROL LEVER** Use the pre-heat flame to heat the metal to be cut to a cherry red colour. When the metal reaches this stage press the oxygen control lever to initiate the cutting process. This feeds additional oxygen through a central hole in the cutting tip. No flame is produced from this hole but the pure oxygen reacts chemically with the hot metal causing it to oxidise i.e. burn away.
- 5.6 SHUTTING DOWN AND LEAVING SAFE** Turn off the acetylene valve on the torch **first** and then turn off the oxygen valve a few moments later. **Note: Turning the gases off in the wrong order can cause damage to the torch.**
- 5.6.2 Close both cylinder valves.
- 5.6.3 Drain gas from oxygen regulator by opening the oxygen valve on the torch handle. Similarly drain gas from the acetylene regulator.
- 5.6.4 Release the adjusting knobs on the regulators. This is done by turning them anti-clockwise.

6. MAINTENANCE

- 6.1 Annual maintenance should be carried out by a person who has sufficient practical experience of oxyacetylene gas equipment and a detailed theoretical knowledge of the functioning of the equipment, the properties of gases used and potential defects and hazards which may occur and their importance to the integrity and safety of the equipment.
- 6.2 Regulator elastomers and seals will wear and deteriorate in service and will also deteriorate out of service. Regulators stored for 1 year or over without use should receive inspection as per the annual maintenance schedule.

EQUIPMENT	MAINTENANCE			
	Each time equipment is used (By the operator)	Annual	Replacement/ Refurbishment Intervals	Replacement/ Refurbishment Guideline
REGULATORS and their integral protective devices.	Visual examination to determine suitability for service (e.g. correct gas, pressure rating, damage, condition of threads and sealing surfaces, oil or grease contamination. Leak test all joints at working pressure.	Functional tests to ensure correct operation	5 years or manufacturers recommendations. NOTE: If regulators are repaired or refurbished this shall be done in accordance with the BCGA Code of practice CP17 by a reputable repairer.	Replace with a new, repaired, or service exchange unit.
FLASHBACK ARRESTORS and their integral cut off valves	Visual examination to determine suitability for service (e.g. gas, pressure rating, damage, condition of threads and sealing surfaces, oil or grease contamination. Leak test all joints at working pressure.	Check unit for flow restriction. Reverse flow to ensure correct operation of non-return valves and pressure sensitive cut off valves where fitted. If of the pressure sensitive type check shut off in the tripped condition in the direction of flow.	5 years or manufacturers recommendations.	Replace with a new, repaired, or service exchange unit.
HOSE ASSEMBLIES (including non- return valves)	Visual safety check to determine suitability for service (e.g. gas, pressure rating, damage), condition of cover (e.g. kinking and twisting), threads and sealing surfaces. Check anti-whip restraints where fitted. Leak test all joints at working pressure.	Reverse hose to ensure the correct operation of non-return valve where fitted. Bend hose in a tight radius to ensure reinforcement is not visible.	Determined by local operating conditions.	Replace as required.
BLOWPIPES	Visual examination of the nozzle and inlet seatings for damage. Leak test all joints at working pressure.	Test valve functions. Blank exits and leak test for internal malfunctions.	Determined by local operating conditions.	Replace with a new, repaired, or service exchange unit.

7. TECHNICAL INFORMATION

7.1. CUTTING CAPACITIES

Mild Steel	Nozzle Size	Operating Pressure (bar - lbf/in ²)		Gas Consumption (ltr/m - ft ³ /h)		
		Oxygen	Acetylene	O ₂ - Cutting	O ₂ - Heating	Acetylene
6mm / 1/4"	1/32"	1.4 - 20	0.30 - 4	14.15 - 30	8.5 - 18	8.0 - 17
13mm / 1/2"	3/64"	2.1 - 30	0.35 - 5	30.70 - 65	10.4 - 22	9.4 - 20
25mm / 1"	1/16"	2.8 - 40	0.40 - 6	67.50 - 143	13.2 - 28	11.8 - 25
50mm / 2"	1/16"	3.1 - 45	0.40 - 6	78.30 - 166	13.2 - 28	11.8 - 25
75mm / 3"	1/16"	3.5 - 50	0.40 - 6	88.70 - 188	13.2 - 28	11.8 - 25

7.2. WELDING CAPACITIES

Mild Steel	Nozzle Size	Operating Pressure (bar - lbf/in ²)		Gas Consumption (ltr/m - ft ³ /h)		
		Oxygen	Acetylene	O ₂ - Welding	O ₂ - Heating	Acetylene
1.2mm / 18SWG	LW02	0.14 - 2	0.14 - 2	11.8 - 25	4.2 - 9	3.8 - 8
2.6mm / 12SWG	LW05	0.28 - 4	0.21 - 3	23.5 - 50	4.2 - 9	3.8 - 8
4mm / 8SWG	LW10	0.35 - 5	0.28 - 4	56.6 - 120	4.2 - 9	3.8 - 8

8. DECLARATION OF CONFORMITY

Declaration of Conformity We, the sole UK importer, declare that the product listed below is in conformity with the following standards and directives.

GAS WELDING/CUTTING KIT

Model: SGA1.V2

BS EN ISO 730:1995 Gas Welding Equipment - Safety Device
Incorporating Flame/Flashback Arrestor
BS EN ISO 5172:1997 Manual blowpipes for welding, cutting and heating

The construction file for this product is held by the Manufacturer and may be inspected, by a national authority, upon request to Jack Sealey Ltd.

Signed by Tim Thompson



6th March 2007

For Jack Sealey Ltd. Sole UK importer of Sealey Power Welders.

NOTE: It is our policy to continually improve products and as such we reserve the right to alter data, specifications and component parts without prior notice.

IMPORTANT: No liability is accepted for incorrect use of this product.

WARRANTY: Guarantee is 12 months from purchase date, proof of which will be required for any claim.

INFORMATION: For a copy of our catalogue and latest promotions call us on 01284 757525 and leave your full name, address and postcode.



Sole UK Distributor
Sealey Group,
Bury St. Edmunds, Suffolk.



01284 757500



01284 703534



www.sealey.co.uk



sales@sealey.co.uk