



# 75W PLASTIC WELDING REPAIR KIT

MODEL NO: **SDL15**

Thank you for purchasing a Sealey product. Manufactured to a high standard, this product will, if used according to these instructions, and properly maintained, give you years of trouble free performance.

**IMPORTANT:** PLEASE READ THESE INSTRUCTIONS CAREFULLY. NOTE THE SAFE OPERATIONAL REQUIREMENTS, WARNINGS & CAUTIONS. USE THE PRODUCT CORRECTLY AND WITH CARE FOR THE PURPOSE FOR WHICH IT IS INTENDED. FAILURE TO DO SO MAY CAUSE DAMAGE AND/OR PERSONAL INJURY AND WILL INVALIDATE THE WARRANTY. KEEP THESE INSTRUCTIONS SAFE FOR FUTURE USE.



Refer to instructions



Wear protective gloves



Hot surfaces



Wear eye protection



Keep dry

## 1. SAFETY

### 1.1. ELECTRICAL SAFETY

- WARNING!** It is the user's responsibility to check the following:  
Check all electrical equipment and appliances to ensure that they are safe before using. Inspect power supply leads, plugs and all electrical connections for wear and damage. Sealey recommend that an RCD (Residual Current Device) is used with all electrical products. You may obtain an RCD by contacting your local Sealey Stockist.

If the product is used in the course of business duties, it must be maintained in a safe condition and routinely PAT (Portable Appliance Test) tested.

Electrical safety information, it is important that the following information is read and understood.

- 1.1.1. Ensure that the insulation on all cables and on the appliance is safe before connecting it to the power supply.
- 1.1.2. Regularly inspect power supply cables and plugs for wear or damage and check all connections to ensure that they are secure.
- 1.1.3. **Important:** Ensure that the voltage rating on the appliance suits the power supply to be used and that the plug is fitted with the correct fuse - see fuse rating in these instructions.

- \* **DO NOT** pull or carry the appliance by the power cable.
- \* **DO NOT** pull the plug from the socket by the cable. Remove the plug from the socket by maintaining a firm grip on the plug.
- \* **DO NOT** use worn or damaged cables, plugs or connectors. Ensure that any faulty item is repaired or replaced immediately by a qualified electrician.

- 1.1.4. This product is fitted with a BS1363/A 13 Amp 3 pin plug.

If the cable or plug is damaged during use, switch the electricity supply and remove from use. Replace a damaged plug with a BS1363/A 13 Amp 3 pin plug. If in doubt contact a qualified electrician.

Class II products are wired with live (brown) and neutral (blue) only, and are marked with the  Class II symbol;

A) Connect the BROWN live wire to the live terminal 'L'.

B) Connect the BLUE neutral wire to the neutral terminal 'N'.

C) After wiring, check that there are no bare wires and ensure that all wires have been correctly connected.

Ensure that the cable outer sheath extends inside the cable restraint and that the restraint is tight.

- \* **DO NOT** connect either wire to the earth terminal.  
Sealey recommend that repairs are carried out by a qualified electrician.

### 1.2 GENERAL SAFETY

- ✓ Familiarise yourself with this products application and limitations, as well as the specific potential hazards peculiar to the welder.
- WARNING!** Disconnect the welder from the mains power before changing accessories, servicing or performing any maintenance.
- ✓ Maintain the welder in good condition (use an authorised service agent).
- ✓ Replace or repair damaged parts. *Use recommended parts only. Unauthorised parts may be dangerous and will invalidate the warranty.*
- WARNING!** Always wear approved eye or face protection when operating the welder.
- ✓ Keep the work area clean, uncluttered and ensure there is adequate lighting.
- ✓ Remove ill fitting clothing. Remove ties, watches, rings, and other loose jewellery, and contain and/ or tie back long hair.
- ✓ Maintain correct balance and footing. Ensure the floor is not slippery and wear non-slip shoes,
- ✓ Secure non stable workpiece with a clamp, vice or other adequate holding device.
- \* **DO NOT** use the welder for a task it was not designed to perform.
- \* **DO NOT** operate the welder if any parts are damaged or missing as this may cause failure and/or possible personal injury.
- \* **DO NOT** hold the workpiece by hand. Use clamps or a vice (not included) to secure the workpiece. Available from your Sealey stockist.
- \* **DO NOT** let the welder get wet or use in damp or wet locations or areas where there is condensation.
- \* **DO NOT** place heating element close to your face (especially eyes, ears, etc) or other persons or animals.
- \* **DO NOT** allow children or untrained persons to operate the welder.
- \* **DO NOT** operate the welder when you are tired or under the influence of alcohol, drugs or intoxicating medication.
- \* **DO NOT** allow the welder to contact skin.
- \* **DO NOT** inhale any vapour given off by the welder.
- \* **DO NOT** carry the welder with your finger on the power switch, or carry by the power cable.
- \* **DO NOT** use the welder where there are flammable liquids, solids or gases such as paint solvents, etc.
- \* **DO NOT** leave the welder unattended whilst it is switched on.
- ✓ When not in use, switch the welder off, remove plug from the power supply and store the tool in a safe, dry child proof area.

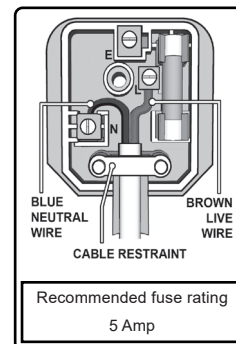

## 2. INTRODUCTION

Maximum control and accuracy provided by pistol grip design. Repairs split bumpers and other cracked plastic parts. Optional high, medium and low settings. Supplied with staples; 0.6mm outside corner (x50), 0.8mm inside corner (x50), 0.6mm flat (x50), 0.8mm flat (x50), 0.6mm wave (x50), 0.8mm wave (x50), soldering iron (x1).

## 3. SPECIFICATION

**MODEL NO:**..... **SDL15**

Electrical Plug Type: .....3-Pin BS

Consumable Parts:

RE06 ..... U-Staple 0.6mm Pack of 100

RE06C ..... Outside Corner Staple 0.6mm Pack of 100

RE06W ..... Wave Staple 0.6mm Pack of 100

RE08 ..... U-Staple 0.8mm Pack of 100

RE08V ..... Inside Staple 0.8mm Pack of 100

RE08W ..... Wave Staple 0.8mm Pack of 100

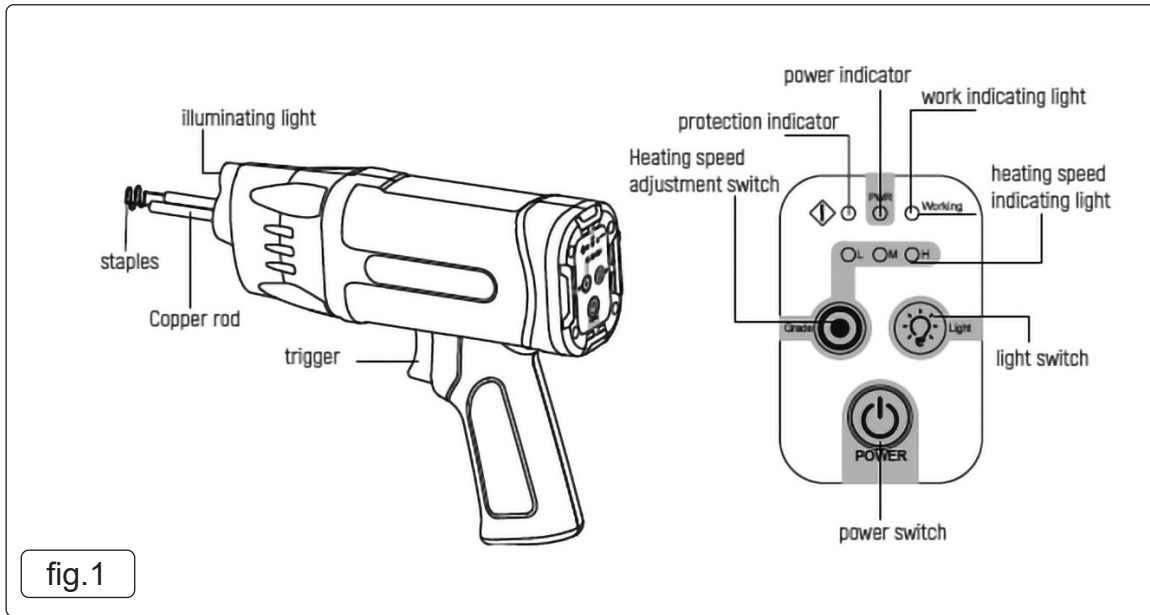

fig.1

## 4. OPERATION

**NOTE:** This appliance is not intended for use by persons (including children) with reduced physical, sensory or mental capabilities or lack of experience and knowledge, unless they have been given supervision or instruction concerning the use of the appliance by a person responsible for their safety. Children should be supervised to ensure that they **DO NOT** play with the appliance.

- ❑ **WARNING!** Remember that whilst operating the gun, both the dispensing nozzle and the staple itself are hot. **DO NOT** allow the nozzle or staple to come into contact with any part of your body or that of anybody else who may be assisting.

### 4.1. PREPARATION

- 4.2. Ensure the work surface is clean and clear before engaging in the task in hand.
- 4.3. Steady the workpiece with an appropriate vice or clamp.
- 4.4. According to the shape of the position to be repaired, select the corresponding staple and heating speed (fig.1). Insert the copper rod in the appropriate direction.
- 4.5. Hold the welder handle tightly, align the staple with the cracks to be repaired, press the trigger, the staple will be heat up (indicating light fig.1 will light when at set heating speed). Melt the staple into the plastic for a few seconds, twist the handle slightly horizontally, so that the transverse part of the staple is completely covered.
- 4.6. Wrap with melted plastic to strengthen the connection, release the trigger and hold it for 3 seconds, then pull out the welder body. Melting is completed.
- 4.7. Cut off the exposed part of the staple, or move it back and forth using a suitable tool i.e. pliers, until it breaks.
- 4.8. Use the ironing head to heat the cracks and the protruding plastic next to it.
- 4.9. When the task is complete, unplug the gun and leave to cool.

## 5. TROUBLE SHOOTING

	Indicator	Reason
1	Yellow light on	Power supply indicator
2	Green light on	Normal operation
3	Red light flash slowly, by 2s/time, and the buzzer sounds;	Over heating protection. (Generally, it will automatically recover within 5 minutes)
4	Red light flash quickly , by 0.5s/time, and the buzzer sounds	Overload/short circuit. Restart the device to recover.
5	Red light on	Open circuit protection

## 6. MAINTENANCE

- ❑ Disconnect from power source before attempting any cleaning or maintenance.
- 6.1. In order to ensure good contact with heating nails, please keep the small holes of copper rods clean.
- 6.2. Do not place it in a dusty place for a long time.
- 6.3. Keep the small hole on the gun body of the device clean to ensure good internal heat dissipation.

Parts support is available for this product. Please email [sales@sealey.co.uk](mailto:sales@sealey.co.uk) or telephone 01284 757500



### WEEE REGULATIONS

Dispose of this product at the end of its working life in compliance with the EU Directive on Waste Electrical and Electronic Equipment (WEEE). When the product is no longer required, it must be disposed of in an environmentally protective way. Contact your local solid waste authority for recycling information.



### ENVIRONMENT PROTECTION

Recycle unwanted materials instead of disposing of them as waste. All tools, accessories and packaging should be sorted, taken to a recycling centre and disposed of in a manner which is compatible with the environment. When the product becomes completely unserviceable and requires disposal, drain any fluids (if applicable) into approved containers and dispose of the product and fluids according to local regulations.

**Note:** It is our policy to continually improve products and as such we reserve the right to alter data, specifications and component parts without prior notice.

**Important:** No Liability is accepted for incorrect use of this product.

**Warranty:** Guarantee is 12 months from purchase date, proof of which is required for any claim.



REGISTER YOUR PURCHASE HERE

Sealey Group, Kempson Way, Suffolk Business Park, Bury St Edmunds, Suffolk. IP32 7AR



01284 757500



01284 703534



[sales@sealey.co.uk](mailto:sales@sealey.co.uk)



[www.sealey.co.uk](http://www.sealey.co.uk)