



# 110V 50L INDUSTRIAL DEHUMIDIFIER

MODEL NO: SDH50110V

Thank you for purchasing a Sealey product. Manufactured to a high standard, this product will, if used according to these instructions, and properly maintained, give you years of trouble free performance.

**IMPORTANT:** PLEASE READ THESE INSTRUCTIONS CAREFULLY. NOTE THE SAFE OPERATIONAL REQUIREMENTS, WARNINGS & CAUTIONS. USE THE PRODUCT CORRECTLY AND WITH CARE FOR THE PURPOSE FOR WHICH IT IS INTENDED. FAILURE TO DO SO MAY CAUSE DAMAGE AND/OR PERSONAL INJURY AND WILL INVALIDATE THE WARRANTY. KEEP THESE INSTRUCTIONS SAFE FOR FUTURE USE.



Refer to instructions



Do not cover



Indoor use only



Caution:  
Risk of fire

## 1. SAFETY

### 1.1. ELECTRICAL SAFETY

- ❑ **WARNING!** It is the responsibility of the owner and the operator to read, understand and comply with the following:  
You must check all electrical products, before use, to ensure that they are safe. You must inspect power cables, plugs, sockets and any other connectors for wear or damage. You must ensure that the risk of electric shock is minimised by the installation of appropriate safety devices. A Residual Current Circuit Breaker (RCCB) should be incorporated in the main distribution board. We also recommend that a Residual Current Device (RCD) is used. It is particularly important to use an RCD with portable products that are plugged into a supply which is not protected by an RCCB. If in any doubt consult a qualified electrician. You may obtain a Residual Current Device by contacting your Sealey stockist.
- ✓ You must also read and understand the following instructions concerning electrical safety.
- 1.1.1. The **Electricity at Work Act 1989** requires that all portable electrical appliances, if used on business premises, are tested by a qualified electrician, using a Portable Appliance Tester (PAT), at least once a year.
- 1.1.2. The **Health & Safety at Work Act 1974** makes owners of electrical appliances responsible for the safe condition of those appliances and the safety of the appliance operators. If in any doubt about electrical safety, contact a qualified electrician.
- ✓ Ensure that the insulation on all cables and on the appliance is safe before connecting it to the power supply.
- ✓ Ensure that cables are always protected against short circuit and overload.
- ✓ Regularly inspect power supply cables and plugs for wear or damage and check all connections to ensure that none are loose.
- ✓ Ensure that the voltage marked on the appliance matches the power supply to be used.
- ✗ **DO NOT** pull or carry the appliance by its power supply lead.
- ✗ **DO NOT** pull the plug from the socket by the power cable.
- ✗ **DO NOT** use worn or damaged cables, plugs or connectors. Immediately have any faulty item repaired or replaced by a qualified electrician.
- ✓ Ensure the unit is correctly earthed via a three-pin 110V plug.
  - a) Connect the GREEN/YELLOW earth wire to the earth terminal 'PE'.
  - b) Connect the BROWN live wire to the live terminal 'L/+'.
  - c) Connect the BLUE neutral wire to the neutral terminal.
  - d) After wiring, check that there are no bare wires, that all wires have been correctly connected, that the cable outer insulation extends past the cable restraint and that the restraint is tight.

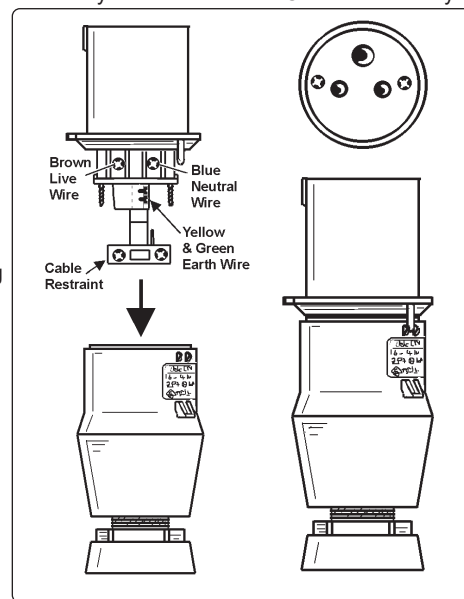

### 1.2. GENERAL SAFETY

- ✓ Check that the dehumidifier is in sound condition and good working order. Take immediate action to repair or replace damaged parts.
- ✓ Use recommended parts only. Unauthorised parts may be dangerous and will invalidate the warranty.
- ✗ **DO NOT** stand or place any object less than 10cm from the front or rear of the unit.
- ✗ **DO NOT** obstruct the air intakes or outlets of the dehumidifier.
- ✗ **DO NOT** place any object into the outlets - the unit has a fan running at high speed, contact with this will cause injury.
- ✗ **DO NOT** operate the dehumidifier when you are tired or under the influence of alcohol, drugs or intoxicating medication.
- ✗ **DO NOT** switch the dehumidifier off by disconnecting it from the mains. ALWAYS switch to the "OFF" position first.
- ✗ **DO NOT** remove the float lever from the water collection tank.
- ✗ **DO NOT** connect or disconnect the plug from the mains with wet hands.
- ✓ Always discard the water from the collection tank, **DO NOT** use it for any other purpose.
- ✓ Place the dehumidifier on a level and stable surface.
- ✗ **DO NOT** use the dehumidifier at ambient temperatures below 5°C.
- ✗ **DO NOT** use the dehumidifier outside.
- ✗ **DO NOT** use means to accelerate the defrosting process or to clean, other than those recommended by the manufacturer.
- ✓ The appliance shall be stored in a room without continuously operating ignition sources (for example: open flames, an operating gas appliance or an operating electric heater.)
- ✗ **DO NOT** pierce or burn.

- ✓ Be aware that refrigerants may not contain an odour.
  - ✓ When using continuous draining, make sure that the drain hose is positioned correctly.
  - ✓ Ensure that heating appliances are not exposed to the flow of air from the dehumidifier.
  - ✓ Before attempting to move the dehumidifier, empty the contents of the collection tank.
  - ✓ Switch off and disconnect it from the mains before attempting any cleaning or other maintenance work.
  - ✓ Ensure that the dehumidifier is correctly turned off when not in use, and stored in a safe, dry area, out of reach of children.
- This appliance can be used by children aged from 8 years and above and persons with reduced physical, sensory or mental capabilities or lack of experience or knowledge if they have been given supervision or instruction concerning use of the appliance in a safe way and understand the hazards involved. Children shall not play with the appliance. Cleaning and user maintenance shall not be made by children without supervision.
- ❑ **WARNING:** If the power cord is damaged, it must be replaced by a professionally trained person.

## 2. INTRODUCTION

Powerful dehumidification capacity, extracts up to 50L of water per day. Removes excess moisture from air, preventing build-up of mildew and mould. Features auto-defrost function, which activates if the room temperature falls too low. The unit has a 24hr timer function for delay starting and auto-shut-off. Washable air filter. Refrigerant is environmentally friendly R290. May be connected to a drain hose for continuous operation. Mounted on castors for manoeuvrability. Fitted with 110V plug.

## 3. SPECIFICATION

**MODEL NO:**.....SDH50110V  
**CO<sub>2</sub> Equivalent:**..... 2.5MPa  
**Condensate Tank:**.....7L (with Auto Shut-Off)  
**Dehumidifying Capacity:**..... 50L/day(30°CRH80%)  
**Freezing Pressure (Max):**..... 2.5MPa  
**Global Warming Potential (Rating):**.....3  
**IP Rating:**..... IP22  
**Maximum Airflow:**..... 300m<sup>3</sup>/hr  
**Power:**..... 600W( 27°C RH60%), 800W(30°C RH80%)  
**Refrigerant:**..... R290/0.2kg  
**Steaming Pressure (Max):**..... 1.0MPa  
**Supply:**.....110V  
**Working Space:**..... 50-120m<sup>3</sup>  
**Working Temperature:**..... 5-35°C

## 4. ASSEMBLY

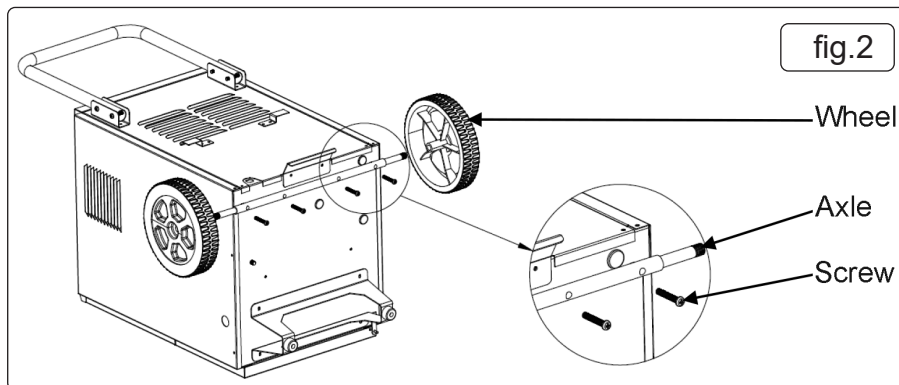

- 4.1. WHEEL INSTALLATION:** Take the machine body, wheel axle, wheel and screws out of the packaging case, and lay the machine body down. As shown in Fig. 2, fix the wheel axle on the machine body with 4 screws, and fix a wheel at both end of the axle. Return the unit to an upright position after attaching the wheels.
- 4.2. HANDLE INSTALLATION:** marry up the holes in the brackets with the holes in the bottom of the handle. It may be useful to fix the screws in the lower holes first, then flip the handle upwards, and secure it with the screws in the upper holes.

**Note:** Once assembled, **DO NOT** use for 2 hours.

## 5. OPERATION

- 5.1. WATER TANK USAGE:** You may use the water tank in two ways.
- 5.1.1. DIRECT USE.** When the water tank is full, the machine automatically shuts down and enters the standby state, the LED displays the "Full Water" signal and the dehumidifier will alarm. When the water tank is emptied and put in place again, the dehumidifier can continue its performance.
- 5.1.2. CONTINUOUS DRAINAGE.** As shown in Fig. 3, to restore the performance of the water tank, you need to take out the water tank, and mount the drain pipe.
- Note:** When using continuous drainage, the drainage pipe shall not be set higher than the water tank.

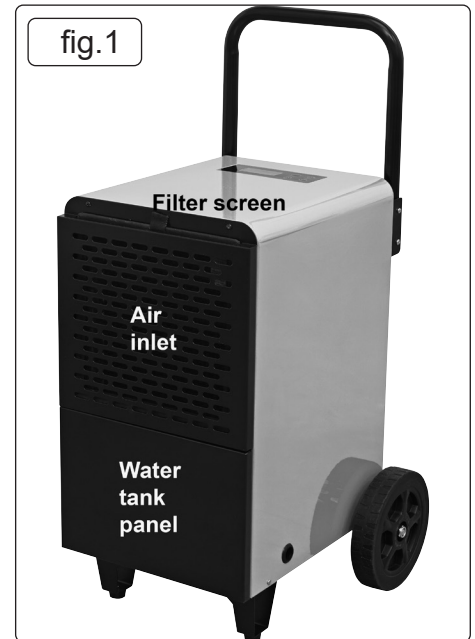

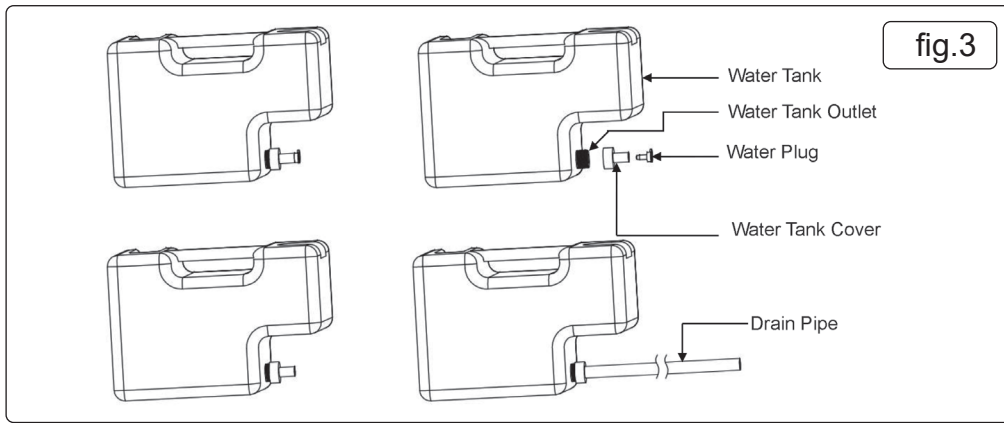

fig.3

5.2. FUNCTION DESCRIPTION

BUTTON	OPERATION INSTRUCTIONS
ON/OFF	Changes between Switch on and Switch off.
+	Adjust different set values in different states; 1. Increases the humidity value set (RH10% to 95%) 2. Increases the timing (hour) set (00 to 24)
-	Adjust different set values in different states; 1. Decreases the humidity value set (RH10% to 95%) 2. Decreases the timing(hour) set (00 to 24)
Timing	Short press the button to launch a cycle to off. Set on/off Timer and Exit

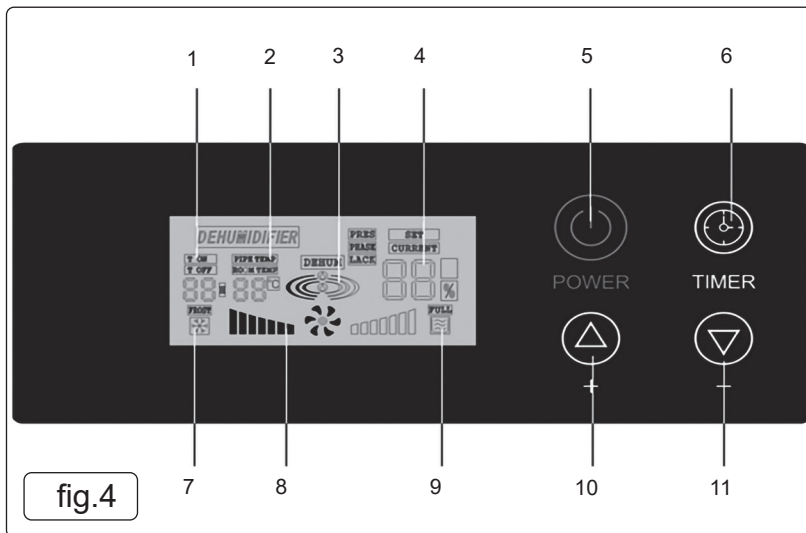

fig.4

ITEM	OPERATION
1	Timer Indicator
2	Temperature Indicator
3	Dehumidification Indicator
4	Humidity Indicator
5	ON/OFF Control
6	Time Set Control
7	Defrosting Indicator
8	Air Speed Indicator
9	Water Full Indicator
10	Increase Control
11	Decrease Control

**NOTE:** Efficiency of the dehumidifier is influenced by the air outside the room. For operating efficiency, try to avoid opening and closing the windows and doors. For best performance, operate the dehumidifier within the usable operating temperature.

5.3. OPERATION

- 5.3.1. Plug the unit in to the mains socket, a beep will be heard when inserting the plug.
- 5.3.2. Press the "ON/OFF" switch and the operation light will illuminate, the humidity display will light to display the previous set humidity. The initial setting for humidity is 60%, after 3 seconds the display will show the current humidity.
- 5.3.3. Press the humidity up or down buttons to adjust to the desired humidity required. If the required humidity is 3% below the current humidity the unit will start automatically, if the set humidity is 3% more than the current humidity the dehumidifier will automatically stop.
- 5.3.4. When setting the humidity to less than 30%, the unit will run continuously and the display will read "CO".
- 5.3.5. To shut the dehumidifier down press the "ON/OFF" switch.

**NOTE:** If the humidity setting is greater than the current humidity the unit will not run.

- **WARNING!** The fan motor and compressor must run for at least 3 minutes while dehumidifying.
- × **DO NOT** start the dehumidifier immediately after shutting down, allow 3 minutes before restarting.

5.4. TIMER FUNCTION

- 5.4.1. To set Timer for power ON mode, with the unit in power OFF state, press the Timer button (fig.4.6). The Timer ON LED (fig.4.1) will flicker and the current set time will be displayed. Use the Increase/ Decrease buttons (fig.4.10, fig.4.11) to set the required value to between 0 and 24 hours. After 10 seconds the selected value is set and the Timer ON led will flicker.
- 5.4.2. To set the Timer for power OFF mode, with the unit in power ON state, press the Timer button (fig.4.6). The Timer OFF LED (fig.4.1) will flicker and the current set time will be displayed. Use the Increase/ Decrease buttons (fig.4.10, fig.4.11) to set the required value to between 0 and 24 hours. After 10 seconds the selected value is set and the Timer OFF led will flicker.

## 5.5. DEFROSTING

5.5.1. The defrosting device works automatically at an interval of approximately every 30 minutes for a duration of approximately 5 minutes when the coil temperature is tested to be  $\leq$  minus 1°C.

The dehumidifying function will stop during the defrosting operation. **DO NOT** disconnect the plug or turn off the unit during the defrosting operation. The defrosting led light (fig.4.7) will light up.

**NOTE:** This dehumidifier does not have a cooling function, it produces heat during the operation and room temperature will rise by 1°C to 4°C. The temperature gets higher while it is operated in a closet, or similar. Furthermore, room temperature will rise because doors and windows are closed and heat is produced from other appliances in the room and from sun radiation.

## 5.6. EMPTYING THE WATER COLLECTION TANK refer to fig.1

5.6.1. During the dehumidifying operation, water is collected in the water collection tank. When the tank is full of water, the dehumidifier stops operating automatically and the warning buzzer beeps twice. The unit will not restart until water collection tank has been emptied.

5.6.2. Open the door and remove water collection tank from the dehumidifier by pulling it gently outwards by holding the sides of the tank.

5.6.3. Hold the tank by the handle and carry it carefully to an emptying point.

5.6.4. Remove the plug at the bottom of the tank and slowly empty the water out of the tank.

5.6.5. Replace the drain plug and refit the tank in the dehumidifier, making sure it is properly back in place as the unit will not restart if it is not fitted correctly.

## 5.7. CONTINUOUS DRAINING

5.7.1. If there is a place suitable for draining, continuous draining can be carried out. The continuous operation enables the dehumidifying operation to continue uninterrupted. See Section 5.1.

## 6. MAINTENANCE

### 6.1. CLEANING THE AIR FILTER

6.1.1. The dehumidifying capacity is lowered when the air cleaning filter becomes clogged.

6.1.2. Open the front door of the unit.

6.1.3. Lift up the filter element from the bottom and lift out of the holder.

6.1.4. To dislodge the dust from the filter, use a vacuum cleaner or tap it lightly.

6.1.5. If the filter is very dirty, wash it carefully in water with a neutral detergent, then rinse well with clean water and leave until dry.

6.1.6. To refit the air filter locate the top of the element into the locating bracket at the top of the door and then locate the lower section into the lower bracket.

6.1.7. Close the door of the dehumidifier.

### 6.2. STORAGE

6.2.1. Unplug the unit, bundle the power cord, and hang the bundled cord at the back of the unit.

6.2.2. Remove the water collection tank and empty the water out of it. Remove the tank cover and wash the inside of the tank with clean water. The tank may be scratched if it is scrubbed strongly with a brush. **DO NOT** remove the float lever from the tank. Wipe off the water on the outside of the tank with a cloth. Refit the tank cover onto the tank and replace the tank in position.

6.2.3. Clean the air filter (see 6.1).

6.2.4. When the unit is to be stored for a long time, wipe the dehumidifier over with a dry soft cloth. To remove dirt, wipe over with a very slightly dampened cloth (never use a wet cloth for cleaning the controls). To avoid deformation or cracking, do not use benzine, thinner or liquid cleaners.

6.2.5. When storing, place in a safe, dry, childproof location. Stand the unit upright and avoid exposure to direct sunlight.

## 7. TROUBLE SHOOTING

7.1. Upon fault of the dehumidifier, please cut off the power supply immediately, unplug the plug and check the following items:

Faults	Cause Analysis	Solutions	
Fails to turn on	Shown as no power	No power to the wall socket.	Check the power supply.
		Check the plug plugged in properly.	Plug the power supply in the socket.
		Check the fuse is not blown.	Replace the fuse.
		Power Transformer is broken.	Replace the transformer.
	Shown as power on	Environmental humidity lower than the set value.	Set again according to the demand.
		If the water tank is installed correctly.	Place the water tank in right position.
If the entire machine is defrosting.		Wait for the completion of defrosting cycle.	
Unfavourable dehumidifying effect	If the air inlet/outlet is obstructed.	Remove the obstacle.	
	If the door and window are open.	Close the door and window.	
	If the indoor temperature is too low.	Don't run the dehumidifier.	
Heavy noise	If the ground is firm and flat.	Resettle the dehumidifier.	
	Dehumidifier is stood precariously.	Resettle the dehumidifier.	
Water leakage	Dehumidifier stood on an incline.	Move dehumidifier to a level surface.	
	Drain pipe/outlet obstructed.	Dismantle the front plate to eliminate blockages.	
E1	Coil sensor fault	Turn to timing for defrosting, to cancel system fault function.	
E2/E3	Fault of humidity & temperature sensor.	Replace the humidity & temperature sensor.	
EE	Refrigerant leakage.	Start the machine after. Ask for help from professionals if the "EE" signal remains.	

- 7.2. If the said methods still fail to eliminate the above problems, please directly contact the manufacturer or agents. **DO NOT** disassemble the dehumidifier, contact Sealey for repairs.



#### ENVIRONMENT PROTECTION

Recycle unwanted materials instead of disposing of them as waste. All tools, accessories and packaging should be sorted, taken to a recycling centre and disposed of in a manner which is compatible with the environment. When the product becomes completely unserviceable and requires disposal, drain any fluids (if applicable) into approved containers and dispose of the product and fluids according to local regulations.



#### WEEE REGULATIONS

Dispose of this product at the end of its working life in compliance with the EU Directive on Waste Electrical and Electronic Equipment (WEEE). When the product is no longer required, it must be disposed of in an environmentally protective way. Contact your local solid waste authority for recycling information.

**Note:** It is our policy to continually improve products and as such we reserve the right to alter data, specifications and component parts without prior notice.

**Important:** No Liability is accepted for incorrect use of this product.

**Warranty:** Guarantee is 12 months from purchase date, proof of which is required for any claim.

Sealey Group, Kempson Way, Suffolk Business Park, Bury St Edmunds, Suffolk. IP32 7AR



01284 757500



01284 703534



sales@sealey.co.uk



www.sealey.co.uk