



50L INDUSTRIAL DEHUMIDIFIER

MODEL NO: SDH50.V4

Thank you for purchasing a Sealey product. Manufactured to a high standard, this product will, if used according to these instructions, and properly maintained, give you years of trouble free performance.

IMPORTANT: PLEASE READ THESE INSTRUCTIONS CAREFULLY. NOTE THE SAFE OPERATIONAL REQUIREMENTS, WARNINGS & CAUTIONS. USE THE PRODUCT CORRECTLY AND WITH CARE FOR THE PURPOSE FOR WHICH IT IS INTENDED. FAILURE TO DO SO MAY CAUSE DAMAGE AND/OR PERSONAL INJURY AND WILL INVALIDATE THE WARRANTY. KEEP THESE INSTRUCTIONS SAFE FOR FUTURE USE.



Refer to instructions



Do not cover



Warning!
Risk of fire



Indoor use only

1. SAFETY

1.1. ELECTRICAL SAFETY

1.1.1. Save all warning and instructions for future reference.

- **WARNING!** It is the responsibility of the owner and the operator to read, understand and comply with the following: You must check all electrical products before use to ensure that they are safe. You must inspect power cables, plugs, sockets and any other connectors for wear or damage. You must ensure that the risk of electric shock is minimised by the installation of appropriate safety devices. A Residual Current Circuit Breaker (RCCB) should be incorporated in the main distribution board. We also recommend that a Residual Current Device (RCD) is used. It is particularly important to use an RCD with portable products that are plugged into a supply which is not protected by an RCCB. If in any doubt consult a qualified electrician. You must also read and understand the following instructions concerning electrical safety:

1.1.2. **The Health & Safety at Work Act 1974** makes owners of electrical appliances responsible for the safe condition of those appliances and the safety of the appliance operators. **If in any doubt about electrical safety, contact a qualified electrician.**

1.1.3. Ensure that the insulation on all cables and on the appliance is safe before connecting it to the power supply.

1.1.4. Ensure that cables are always protected against short circuit and overload.

1.1.5. Regularly inspect power supply cables and plugs for wear or damage and check all connections to ensure that none are loose.

1.1.6. **Important:** Ensure that the voltage marked on the appliance matches the power supply to be used and that the plug is fitted with the correct fuse.

- ▲ **DANGER!** If the power cable for this equipment is damaged, it must be replaced by the manufacturer or its after-sales service or similarly trained personnel to avoid danger.

- x **DO NOT** pull or carry the appliance by the power cable.

- x **DO NOT** pull the plug from the socket by the cable.

- ✓ If the supply cord is damaged, it must be replaced by the manufacturer, its service agent or similarly qualified persons in order to avoid a hazard."

- x **DO NOT** use worn or damaged cables, plugs or connectors. Immediately have any faulty item repaired or replaced by a qualified electrician.

1.1.7. **Over/current Protection:** The user has to make provision for the installation of the over-current protection of the power circuit.

1.1.8. **Electrical disconnecting device:** The user has to make provisions for the installation of the electrical disconnecting device of the power circuit. The supply disconnection device is to be in accordance with EN 60204-1:2006.

1.2. GENERAL SAFETY

- ✓ The appliance shall be disconnected from its power source during maintenance.

- ✓ Always operate the unit from a power source of equal voltage, frequency and rating as indicated on the product identification plate.

- ✓ Always use a power outlet that is grounded.

- ✓ Unplug the power cord or disconnect the power source (RCD) when cleaning or when not in use.

- x **DO NOT** stand or place any object less than 10cm from the front or rear of the unit.

- x **DO NOT** obstruct the air intakes or outlets of the dehumidifier.

- ✓ Always discard the water from the collection tank.

- x **DO NOT** use it for any other purpose.

- ✓ Place the dehumidifier on a level and stable surface.

- x **DO NOT** use the dehumidifier at ambient temperatures below 5°C.

- x **DO NOT** operate with wet hands. Prevent water from spilling onto the unit.

- x **DO NOT** immerse or expose the unit to rain, moisture or any other liquid.

- x **DO NOT** leave the unit running unattended. Do not tilt or turn over the unit.

- x **DO NOT** unplug while the unit is operating.

- x **DO NOT** unplug by pulling on the power cord.

- x **DO NOT** use an extension cord or an adapter plug.

- x **DO NOT** put objects on the unit.

- x **DO NOT** climb or sit on the unit.

- x **DO NOT** insert fingers or other objects into the air outlet.

- x **DO NOT** touch the air inlet or the aluminium fins of the unit.

- x **DO NOT** operate the unit if it is dropped, damaged or showing signs of product malfunction.

- x **DO NOT** clean the appliance with any chemicals.

- ✓ Ensure the unit is far away from fire, inflammable, or explosive objects.

- ✓ The unit shall be installed in accordance with national wiring regulations.

- ✗ **DO NOT** use means to accelerate the defrosting process or to clean, other than those recommended by the manufacture.
- ✓ The appliance shall be stored in a room without continuously operation sources (for example: open flames, an operating gas appliance or an operating electric heater).
- ✓ The appliance shall be stored so as to prevent mechanical damage from occurring.
- ✗ **DO NOT** pierce or burn, even after use.
- ✓ Be aware that refrigerants may not contain an odour.
- ✓ Pipe-work shall be protected from physical damage and shall not be installed in an unventilated space, if that space is smaller than 6 m².
- ✓ Compliance with national gas regulations shall be observed.
- ✓ Keep any required ventilation openings clear of obstruction.
- ✓ The appliance shall be stored in a well-ventilated area where the room size corresponds to the room area as specified for operation.
- ☐ **WARNING!** Any person who is involved with working on or breaking into a refrigerant circuit should hold a current valid certificate from an industry-accredited assessment authority.
- ✗ **DO NOT** use this appliance whilst you are tired or under the influence of drugs, alcohol, or medication. A moment inattention whilst operating power tools may result in serious injury.
- ✓ Children from age 8 years and above, persons with reduced physical, sensory, or mental capabilities those with lack of experience and knowledge can use the appliance, if they have been given supervision or instruction concerning use of the appliance in a safe way to understand the hazards involved.
- ✓ Children shall NOT play with the appliance. Cleaning and user maintenance on the appliance shall not be made by children without supervision. The appliance shall be disconnected from its power source during service and when replacing parts and, if that the removal of the plug is foreseen, it shall be clearly indicated that the removal of the plug has to be such that an operator can check from any of the points to which he has access that the plug remains removed.
- ☐ **WARNING!** Item must be serviced by an authorised agent.
- ✓ Please follow these warnings when servicing the dehumidifier

1.3. SPECIFIC DEHUMIDIFIER SAFETY WARNINGS

1.3.1. CHECKS TO THE AREA

Prior to beginning work on systems containing flammable refrigerants, safety checks are necessary to ensure that the risk of ignition is minimized. For repair to the refrigerating system, the following precautions shall be complied with prior to conducting work on the system.

1.3.2. WORK PROCEDURE

Work shall be undertaken under a controlled procedure so as to minimize the risk of a flammable gas or vapour being present while the work is being performed.

1.3.3. GENERAL WORK AREA

All maintenance staff and others working in the local area shall be instructed on the nature of work being carried out. Work in confined spaces shall be avoided. The area around the workspace shall be sectioned off. Ensure that the conditions within the area have been made safe by control of flammable material.

1.3.4. CHECKING FOR PRESENCE OF REFRIGERANT

The area shall be checked with an appropriate refrigerant detector prior to and during work, to ensure the technician is aware of potentially toxic or flammable atmospheres. Ensure that the leak detection equipment being used is suitable for use with all applicable refrigerants, i.e. non-sparking, adequately sealed or intrinsically safe.

1.3.5. PRESENCE OF FIRE EXTINGUISHER

If any hot work is to be conducted on the refrigerating equipment or any associated parts, appropriate fire extinguishing equipment shall be available to hand. Have a dry powder or CO₂ fire extinguisher adjacent to the charging area.

1.3.6. NO IGNITION SOURCES

No person carrying out work in relation to a refrigerating system which involves exposing any pipe work shall use any sources of ignition in such a manner that it may lead to the risk of fire or explosion. All possible ignition sources, including cigarette smoking, should be kept sufficiently far away from the site of installation, repairing, removing and disposal, during which refrigerant can possibly be released to the surrounding space. Prior to work taking place, the area around the equipment is to be surveyed to make sure that there are no flammable hazards or ignition risks. "No Smoking" signs shall be displayed.

1.3.7. VENTILATED AREA

Ensure that the area is in the open or that it is adequately ventilated before breaking into the system or conducting any hot work. A degree of ventilation shall continue during the period that the work is carried out. The ventilation should safely disperse any released refrigerant and preferably expel it externally into the atmosphere.

1.3.8. CHECKS TO THE REFRIGERATING EQUIPMENT

1.3.8.1. Where electrical components are being changed, they shall be fit for the purpose and to the correct specification. At all times, the manufacturer's maintenance and service guidelines shall be followed. If in doubt, consult the manufacturer's technical department for assistance.

The following checks shall be applied to installations using flammable refrigerants: The actual refrigerant charge is in accordance with the room size within which the refrigerant containing parts are installed.

1.3.8.2. The ventilation machinery and outlets are operating adequately and are not obstructed.

1.3.8.3. If an indirect refrigerating circuit is being used, the secondary circuit shall be checked for the presence of refrigerant.

1.3.8.4. Marking to the equipment continues to be visible and legible. Markings and signs that are illegible shall be corrected.

1.3.8.5. Refrigerating pipe or components are installed in a position where they are unlikely to be exposed to any substance which may corrode refrigerant containing components, unless the components are constructed of materials which are inherently resistant to being corroded or are suitably protected against being so corroded.

1.3.9. CHECKS TO ELECTRICAL DEVICES

1.3.9.1. Repair and maintenance to electrical components shall include initial safety checks and component inspection procedures. If a fault exists that could compromise safety, then no electrical supply shall be connected to the circuit until it is satisfactorily dealt with. If the fault cannot be corrected immediately but it is necessary to continue operation, an adequate temporary solution shall be used. This shall be reported to the owner of the equipment so all parties are advised.

1.3.9.2. Initial safety checks shall include:

- that capacitors are discharged: this shall be done in a safe manner to avoid possibility of sparking..
- that no live electrical components and wiring are exposed while charging, recovering or purging the system.
- that there is continuity of earth bonding.

1.3.10. REPAIRS TO SEALED COMPONENTS

1.3.10.1. During repairs to sealed components, all electrical supplies shall be disconnected from the equipment being worked upon prior to any removal of sealed covers, etc. If it is absolutely necessary to have an electrical supply to equipment during servicing, then a permanently operating form of leak detection shall be located at the most critical point to warn of a potentially hazardous situation.

1.3.10.2. Particular attention shall be paid to the following to ensure that by working on electrical components, the casing is not altered in such a way that the level of protection is affected. This shall include damage to cables, excessive number of connections, terminals not made to original specification, damage to seals, incorrect fitting of glands, etc.

1.3.10.3. Ensure that the apparatus is mounted securely.

1.3.10.4. Ensure that seals or sealing materials have not degraded to the point that they no longer serve the purpose of preventing the ingress of flammable atmospheres. Replacement parts shall be in accordance with the manufacturer's specifications.

1.3.11. REPAIR TO INTRINSICALLY SAFE COMPONENTS

- * **DO NOT** apply any permanent inductive or capacitance loads to the circuit without ensuring that this will not exceed the permissible voltage and current permitted for the equipment in use.

1.3.11.1. Intrinsically safe components are the only types that can be worked on while live in the presence of a flammable atmosphere. The test apparatus shall be at the correct rating.

1.3.11.2. Replace components only with parts specified by the manufacturer. Other parts may result in the ignition of refrigerant in the atmosphere from a leak.

1.3.12. CABLING

Check that cabling will not be subject to wear, corrosion, excessive pressure, vibration, sharp edges or any other adverse environmental effects. The check shall also take into account the effects of aging or continual vibration from sources such as compressors or fans.

1.3.13. DETECTION OF FLAMMABLE REFRIGERANTS

Under no circumstances shall potential sources of ignition be used in the searching for or detection of refrigerant leaks. A halide torch (or any other detector using a naked flame) shall not be used.

1.3.14. REMOVAL AND EVACUATION

1.3.14.1. When breaking into the refrigerant circuit to make repairs – or for any other purpose – conventional procedures shall be used.

However, for flammable refrigerants it is important that best practice is followed since flammability is a consideration. The following procedure shall be adhered to:

- remove refrigerant;
- purge the circuit with inert gas;
- evacuate;
- purge with inert gas;
- open the circuit by cutting or brazing.

1.3.14.2. The refrigerant charge shall be recovered into the correct recovery cylinders. For appliances containing flammable refrigerants the system shall be purged with oxygen-free nitrogen to render the appliance safe for flammable refrigerants. This process may need to be repeated several times. Compressed air or oxygen shall not be used for purging refrigerant systems.

1.3.14.3. For appliances containing flammable refrigerant, purging shall be achieved by breaking the vacuum in the system with oxygen-free nitrogen and continuing to fill until the working pressure is achieved, then venting to atmosphere, and finally pulling down to a vacuum. This process shall be repeated until no refrigerant is within the system. When the final oxygen-free nitrogen charge is used, the system shall be vented down to atmospheric pressure to enable work to take place. This operation is absolutely vital if brazing operations on the pipe-work are to take place.

1.3.14.4. Ensure that the outlet for the vacuum pump is not close to any potential ignition sources and that ventilation is available.

1.3.15. CHARGING PROCEDURES

1.3.15.1. In addition to conventional charging procedures, the following requirements shall be followed.

- Ensure that contamination of different refrigerants does not occur when using charging equipment. Hoses or lines shall be as short as possible to minimise the amount of refrigerant contained in them.
- Cylinders shall be kept in an appropriate position according to the instructions.
- Ensure that the refrigerating system is earthed prior to charging the system with refrigerant.
- Label the system when charging is complete (if not already).
- Extreme care shall be taken not to overfill the refrigerating system.

1.3.16. Prior to recharging the system, it shall be pressure-tested with the appropriate purging gas. The system shall be leak-tested on completion of charging but prior to commissioning. A follow up leak test shall be carried out prior to leaving the site.

1.3.17. DECOMMISSIONING

1.3.17.1. Before carrying out this procedure, it is essential that the technician is completely familiar with the equipment and all its detail. It is recommended good practice that all refrigerants are recovered safely. Prior to the task being carried out, an oil and refrigerant sample shall be taken in case analysis is required prior to re-use of recovered refrigerant.

It is essential that electrical power is available before the task is commenced.

Become familiar with the equipment and its operation.

Isolate system electrically.

1.3.17.2. Before attempting the procedure, ensure that:

- mechanical handling equipment is available, if required, for handling refrigerant cylinders.
- all personal protective equipment is available and being used correctly.
- the recovery process is supervised at all times by a competent person.
- recovery equipment and cylinders conform to the appropriate standards.

Pump down refrigerant system, if possible.

If a vacuum is not possible, make a manifold so that refrigerant can be removed from various parts of the system.

Make sure that cylinder is situated on the scales before recovery takes place.

Start the recovery machine and operate in accordance with instructions.

- * **DO NOT** overfill cylinders (no more than 80 % volume liquid charge).

- * **DO NOT** exceed the maximum working pressure of the cylinder, even temporarily.
- 1.3.17.3. When the cylinders have been filled correctly and the process completed, make sure that the cylinders and the equipment are removed from site promptly and all isolation valves on the equipment are closed off.
- 1.3.17.4. Recovered refrigerant shall not be charged into another refrigerating system unless it has been cleaned and checked.
- 1.3.18. LABELLING**
- 1.3.18.1. Equipment shall be labelled stating that it has been de-commissioned and emptied of refrigerant. The label shall be dated and signed. For appliances containing flammable refrigerants, ensure that there are labels on the equipment stating the equipment contains flammable refrigerant.
- 1.3.19. RECOVERY**
- 1.3.19.1. When removing refrigerant from a system, either for servicing or decommissioning, it is recommended good practice that all refrigerants are removed safely.
- 1.3.19.2. When transferring refrigerant into cylinders, ensure that only appropriate refrigerant recovery cylinders are employed. Ensure that the correct number of cylinders for holding the total system charge is available. All cylinders to be used are designated for the recovered refrigerant and labelled for that refrigerant (i.e. special cylinders for the recovery of refrigerant). Cylinders shall be complete with pressure-relief valve and associated shut-off valves in good working order. Empty recovery cylinders are evacuated and, if possible, cooled before recovery occurs.
- 1.3.19.3. The recovery equipment shall be in good working order with a set of instructions concerning the equipment that is at hand and shall be suitable for the recovery of all appropriate refrigerants including, when applicable, flammable refrigerants. In addition, a set of calibrated weighing scales shall be available and in good working order. Hoses shall be complete with leak-free disconnect couplings and in good condition. Before using the recovery machine, check that it is in satisfactory working order, has been properly maintained and that any associated electrical components are sealed to prevent ignition in the event of a refrigerant release. Consult manufacturer if in doubt.
- 1.3.19.4. The recovered refrigerant shall be returned to the refrigerant supplier in the correct recovery cylinder, and the relevant waste transfer note arranged. **DO NOT** mix refrigerants in recovery units and especially not in cylinders.
- 1.3.19.5. If compressors or compressor oils are to be removed, ensure that they have been evacuated to an acceptable level to make certain that flammable refrigerant does not remain within the lubricant. The evacuation process shall be carried out prior to returning the compressor to the suppliers.

2. INTRODUCTION

Powerful dehumidification capacity, extracts up to 50 litres of water per day. Removes excess moisture from air, preventing build-up of mildew and mould. Features auto-defrost function, which activates if the room temperature falls too low. The unit has a 24hr timer function for delay starting and auto-shut-off. Modern display shows air humidity as well as ambient air temperature. Washable air filter. Refrigerant is environmentally friendly R290. May be connected to a drain hose for continuous operation. Mounted on two large wheels for easy manoeuvrability.

3. SPECIFICATION

MODEL NO:.....**SDH50.V4**
CO2 Equivalent:..... 0.0046t
Condensate Tank:..... 5.5L (with Auto-Shut-Off)
Dehumidifying Capacity: 50L/day(30°C RH80%)
Freezing Pressure (Max):.....2.5MPa
Fuse Rating:..... 10A
Global Warming Potential (Rating):..... 20
IP Rating:..... IPX0
Mass:..... 230g
Maximum Airflow:.....450m³/hr
Nett Weight:..... 36kg
Plug Type:.....3-Pin
Power Supply Cable Length:..... 1.5m
Power: Rated – 545W (27°C RH60%), Max – 650W
.....(30°C RH80%)
Refrigerant:..... R290/0.230kg
Steaming Pressure (Max):.....3.2MPa
Supply:..... 230V ~ 50Hz
Working Space:.....50-120m³
Working Temperature:.....5-38°C

4. FEATURES

Features are as in fig.1.

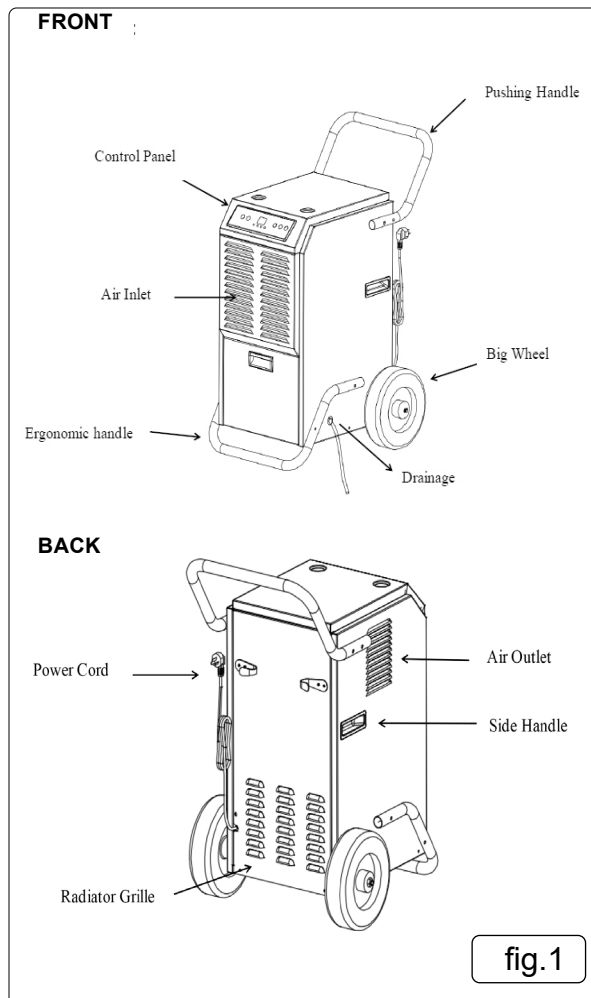

fig.1

5. ASSEMBLY

Assemble as in fig.2

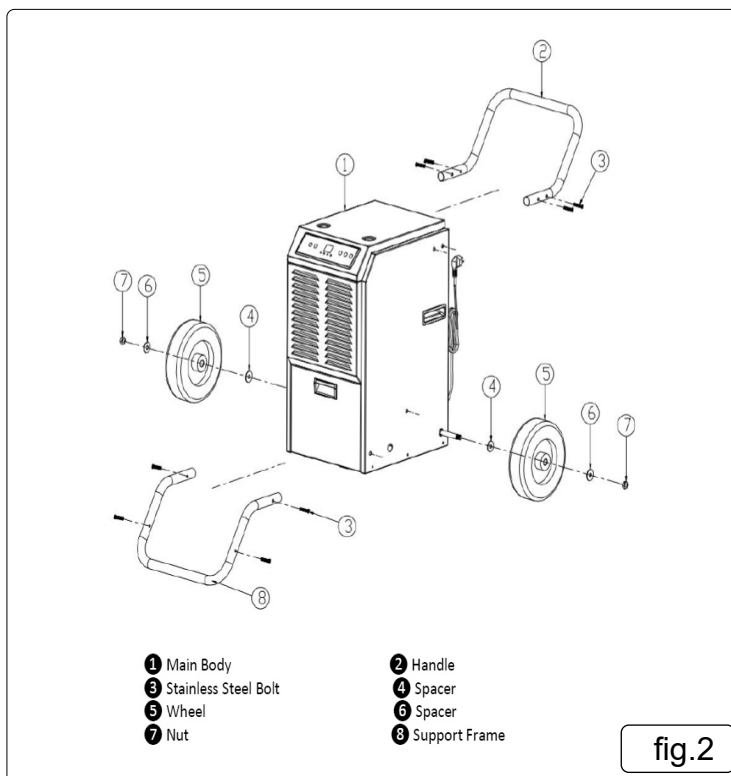

fig.2

6. OPERATION

6.1. OPERATION

- 6.1.1. Check the device after unpacking for any damages or scratches on it.
- 6.1.2. Operate this unit in an ambient temperature from 5°C to 38°C.
 - * **DO NOT** use in the outdoors. This dehumidifier is intended for indoor residential applications only.
 - * **DO NOT** operate in close proximity to walls, curtains, or other objects that may block inlet and outlet.
 - * **DO NOT** operate or store the unit in direct sunlight or rain.
- 6.1.3. Keep doors and windows close for better energy saving.
- 6.1.4. It is normal for air outlet to feel warm to touch after continuous operation on hot days.
- 6.1.5. Empty the water tank before moving the device.
- 6.1.6. Make sure the water tank is correctly fitted otherwise the unit will not operate properly.
- 6.1.7. Keep the air inlet and outlet free of obstacles.
- 6.1.8. Adjust the wind deflector in the upward direction prior to start up.
- 6.1.9. If tipped more than 45°, allow the unit to set upright for at least 24 hours before start up.
- 6.1.10. The dehumidifier starts up in the mode selected when the unit was last used.
- 6.1.11. There is a protective 3-minutes time delay of the compressor. Wait 3 minutes for the dehumidifier to resume dehumidification.

6.2. BUTTON FUNCTIONS

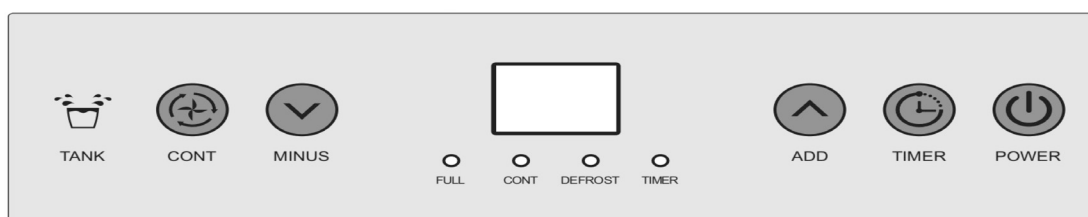

POWER Press this button to turn the unit on/ off. The screen will light up to show the current ambient humidity level when the unit is on. The default setting for mode and humidity level are: continuous and 50%.



NOTE: The pump will keep operating if it hasn't finished draining when the unit is turned off, and will shut down after it finishes.

CONT In the intelligent dehumidification mode, press this button to switch to the continuous dehumidification mode. The set humidity level is non-adjustable under this mode, and the machine will operate continuously regardless of the ambient humidity level. In the continuous dehumidification mode, press this button to switch to the intelligent dehumidification mode, where the set humidity level is adjustable.



MINUS Each press of this button will decrease the set humidity level/timer by 5 %/1 hour within the range of 20-90%/0-24 hours.



ADD Each press of this button will increase the set humidity level/timer by 5 %/1 hour within the range of 20-90%/0-24 hours.







TIMER The first press of this button will turn the timer on, and the timer indicator will light up. Press the ADD or MINUS button to increase or decrease the timer within a 24 hour time frame. In the power-on state, the timer indicates the length of operation time. In the standby state, the timer indicates the length of time until the reserved turning-on time. The timer is memoryless, so it needs to be reset each time. A long press (5 seconds) of this button will temporarily switch the screen from displaying humidity level to displaying ambient temperature



NOTE The dehumidifier starts operating in the mode that it was last in. The dehumidifier starts dehumidifying if the room humidity level is 3% higher than the set humidity level, and stops if the room humidity level is 3% lower than the set humidity level.

6.3. INDICATORS

 FULL : Water Full Indicator	 CONT : Continuous Mode Indicator
 DEFROS : Defrosting Indicator	 TIMER : Timer Indicator

- 6.3.1. When the water tank is full, the water tank light goes on red and alarm goes on after 5 seconds. Buzzer beeps 15 times and the compressor and fan shut off. After the water tank is emptied, the machine will automatically switch to the previous mode while the compressor will be in 3 minutes of self-protect. Alarm will stop in 3 seconds after the water tank was emptied and put back, fan starts, and compressor will start in 3 minutes.
- 6.3.2. Compressor will not need 3 minutes for self-protect if it was the first time to start the machine, press POWER and power off; power on, press POWER, compressor starts immediately.
- 6.3.3. The system has auto memory. When all the mode setting has been finished, if there is sudden power cut during operation, or the power jack slips out, the system may store the current status before the power is cut and enter the operation mode before power cut automatically after power is supplied.

6.4. DEFROST FUNCTION

- 6.4.1. The compressor and fan will shut off when the environmental temperature goes below 5°C or above 38°C .
- 6.4.2. Defrost requirement: Compressor running for 30 minutes, temperature sensor sense the temperature $\leq 30.2^{\circ}\text{F}$, (last for 10 seconds), compressor stops, defrost starts, fan continues, defrost light turns on, when the pipe temperature goes to 41°F or the defrost last for 15 minutes, defrost stops.

NOTE: During defrost, light won't be off until the defrosting is over.

6.5. DRAINAGE INSTALLATION (fig.3)

- 6.5.1. When the tank is full, the FULL light will turn on.
- 6.5.2. The unit will make a buzzing sound. To stop this, press the power button to turn off the machine.
- 6.5.3. To empty the water tank, open the front panel to access the water tank.
- 6.5.4. Grab the handle of the water tank and pull it out horizontally.
- 6.5.5. After disposing of the water, replace the tank and close the front panel.

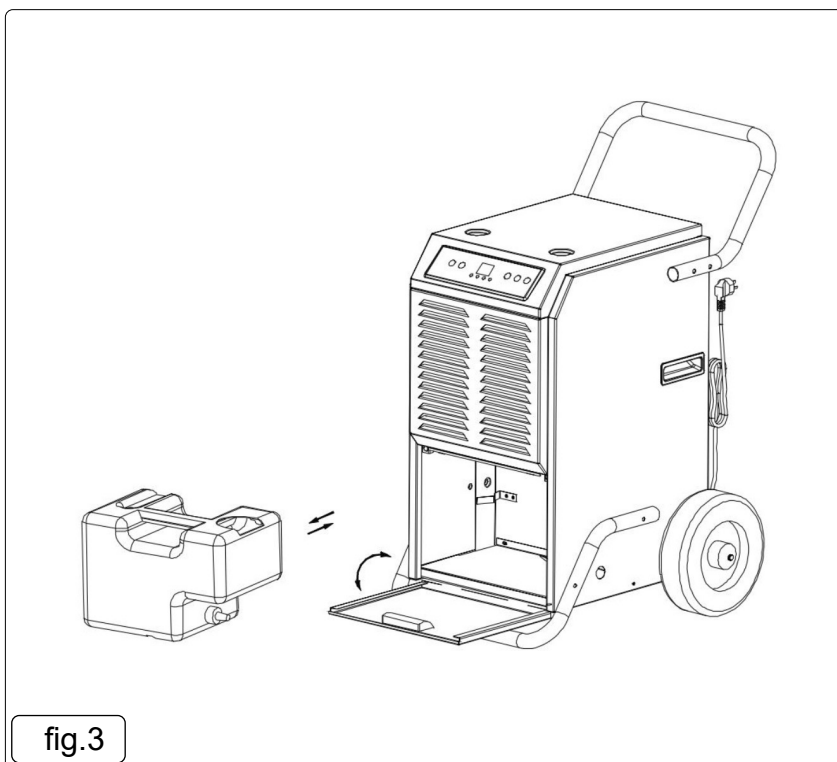
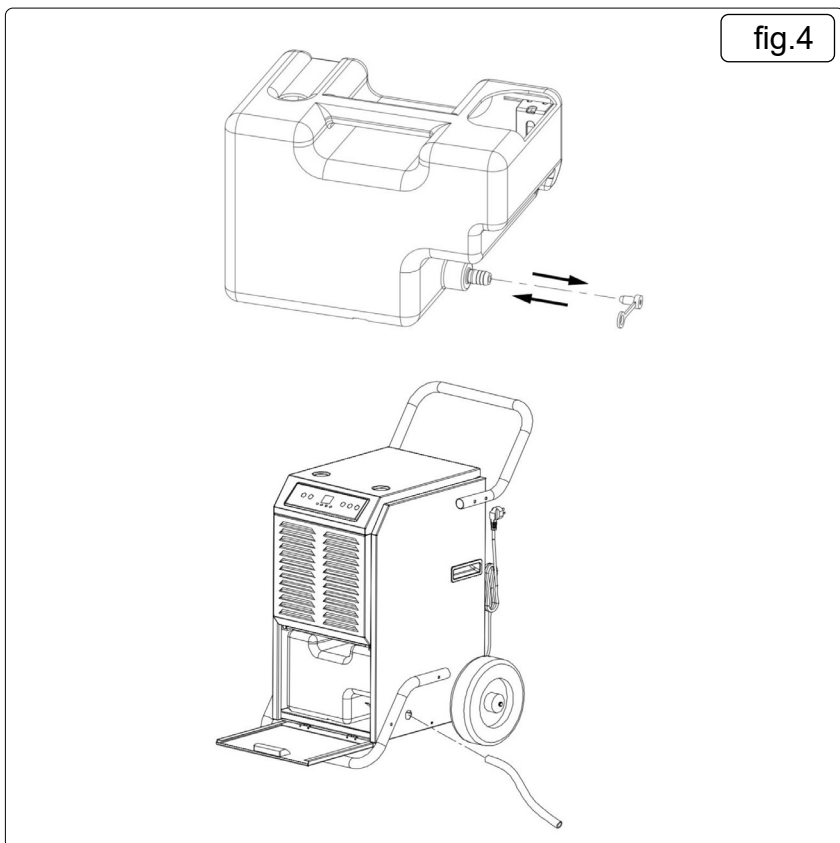

fig.3

6.6. CONTINUOUS DRAINAGE (fig.4)

- 6.6.1. In extremely wet conditions, the tank may need frequent clearing. It can be set up for continuous drainage by doing the following: Open the front cover, remove the tank, and clear the water from the tank.
- 6.6.2. Remove the plug and install the included drain pipe to the connector, direct the pipe to the desired area before operate the machine. See the pictures below.

- 6.6.3. Make sure the water tank and drain pipe are not blocked, shut the front panel.
- 6.6.4. When you do not use continuous drainage and turn to use water tank again, just use the plug to stop the water outflow from the connector.



- ❑ **WARNING!** Do not block the drainage hose. The end of the drainage pipe should not be higher than the outlet hole. If the drainage pipe end is higher than the outlet hole, water will not drain properly and could damage components of the unit.

7. MAINTENANCE

- ❑ **WARNING!** Before cleaning or conducting maintenance, please turn off and unplug the machine to avoid the risk of electrocution.

7.1. CLEANING

7.1.1. BODY CLEANING

- 7.1.1.1. Use a soft and slightly moist cloth to clean the dehumidifier's body. Do not use cleanser, steel wool, chemically treated dust-proof cloth, gasoline, benzene, thinners, or other chemical solvents in case of damage or distortion.

7.2. FILTER CLEANING (fig.5)

- 7.2.1.1. Pull to open the dehumidifier's back panel, and slide the filter upward to take it out from the panel.
- 7.2.1.2. Use a vacuum cleaner to gently vacuum the dust on the filter's surface.
- 7.2.1.3. If the filter is dirty, wash it with water and a soft detergent, dry it thoroughly afterwards.
- 7.2.1.4. Put the filter back in the back panel, and close the dehumidifier's back panel.
- 7.2.1.5. Maintain the dehumidifier in good condition and replace any damaged or worn parts. Use genuine parts only. Unauthorised parts may be dangerous and will invalidate your warranty.

7.3. STORAGE

If you are not going to use the appliance for an extended period of time (more than a few weeks), it is best to clean and dry it completely before preserving the appliance in a ventilating, dry, corrosive gas-free, and safe indoor space. The appliance must be kept in an upright position when in storage.

NOTE: Manual drainage can help with completely drying the appliance.

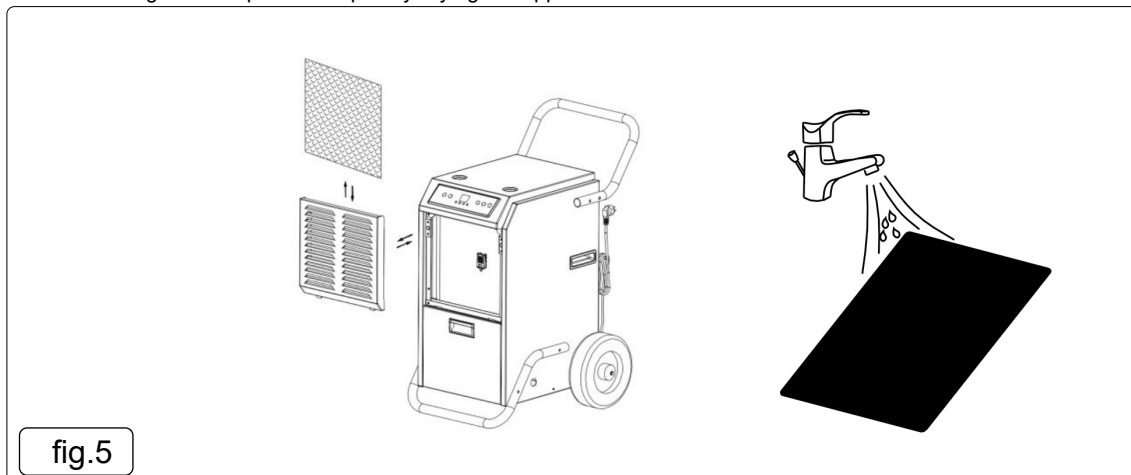

8. TROUBLESHOOTING

TROUBLE	CAUSE	SOLUTION
Not operating	Unit is not plugged in.	Plug in the unit.
	Room temperature is under 5°C or above 38°C.	To protect the machine, use it only when ambient temperature is between 5°C and 38°C.
Humidity level not dropping	When the humidity set point is 2% higher than the ambient humidity level.	Reset the humidity to a lower set point, or power the machine off if the ambient humidity level already satisfies you.
Reduced dehumidifying capacity	Filter jammed.	Clean the filter as instructed.
	Air-in and/or Air-out louvres jammed.	Clear the blockage from Air-in and/or Air-out louvres.
No air inlet	Filter or air-in louvre jammed.	Clean the filter as instructed or clean the louvre blockage.
Loud noise	Machine tilted.	Move it to a flat ground.
	Filter jammed.	Clean the filter as instructed.
Error Code 'E1'	Temperature sensor problem.	Change the sensor.
Error Code 'E2'	Humidity sensor problem.	Change the sensor.
Error Code 'CL'	When the ambient temperature drops below 5°C , this error code will appear, and the compressor and fan will shut down.	
Error Code 'CH'	When the ambient temperature is above 38°C, this error code will appear, and the compressor and fan will shut down.	
Error Code 'LO'	When the ambient humidity drops below 20%, this error code will appear, and the compressor and fan will shut down.	
Error Code 'HI'	When the ambient humidity is above 95%, this error code will appear, but the compressor and fan will keep operating.	
Error Code 'E4'	Water is full or the pump is malfunctioning.	Drain out water or contact customer service for repairs.

- ❑ **WARNING!** If the Water Full indicator is always on, there may be a malfunction in the machine. Please seek technical support from professionals. If anything unexpected happens, please turn off and unplug the machine immediately, and seek technical support from certified electrical engineers.

If the said methods above still fail to eliminate the above problems, please directly contact the manufacturer or agents. **DO NOT** disassemble the dehumidifier, contact Sealey for repairs.

It's normal to hear the sound of the circulation of refrigerant when the dehumidifier runs.

The deviation between the humidity shown on the sensor and the actual humidity is normal, due to impact by the location, environment and temperature.

Since the cooled air is dried by the condenser before being discharged during operation of the dehumidifier, it's normal for the air discharged to be hotter than the environment.

Since the dehumidifying effect is associated with the temperature and humidity of the environment, the higher the temperature and humidity of the environment, normally the greater the dehumidifying effect; while the lower the temperature and humidity of the environment, typically the lower the dehumidifying effect.



ENVIRONMENT PROTECTION

Recycle unwanted materials instead of disposing of them as waste. All tools, accessories and packaging should be sorted, taken to a recycling centre and disposed of in a manner which is compatible with the environment. When the product becomes completely unserviceable and requires disposal, drain any fluids (if applicable) into approved containers and dispose of the product and fluids according to local regulations.



Note: It is our policy to continually improve products and as such we reserve the right to alter data, specifications and component parts without prior notice. Please note that other versions of this product are available. If you require documentation for alternative versions, please email or call our technical team on technical@sealey.co.uk or 01284 757505.

Important: No Liability is accepted for incorrect use of this product.

Warranty: Guarantee is 12 months from purchase date, proof of which is required for any claim.

Sealey Group, Kempson Way, Suffolk Business Park, Bury St Edmunds, Suffolk. IP32 7AR

01284 757500

sales@sealey.co.uk

www.sealey.co.uk