



# COMPACT STEEL CREEPER/SEAT WITH 6 WHEELS

MODEL NO: **SCR791**

Thank you for purchasing a Sealey product. Manufactured to a high standard, this product will, if used according to these instructions, and properly maintained, give you years of trouble free performance.

**IMPORTANT:** PLEASE READ THESE INSTRUCTIONS CAREFULLY. NOTE THE SAFE OPERATIONAL REQUIREMENTS, WARNINGS & CAUTIONS. USE THE PRODUCT CORRECTLY AND WITH CARE FOR THE PURPOSE FOR WHICH IT IS INTENDED. FAILURE TO DO SO MAY CAUSE DAMAGE AND/OR PERSONAL INJURY AND WILL INVALIDATE THE WARRANTY. KEEP THESE INSTRUCTIONS SAFE FOR FUTURE USE.



Refer to instructions



Wear eye protection

## 1. SAFETY

- WARNING!** Ensure health & safety, local authority and general workshop practice regulations are strictly adhered to when using this equipment.
- ✓ Familiarise yourself with product application and limitations, as well as the specific potential hazards peculiar to this product.
- ✓ Maintain creeper in good condition. Use an authorised service agent.
- ✓ Replace or repair damaged parts. Use only genuine parts only. Non authorised parts will invalidate warranty.
- WARNING!** Use the creeper on level and solid ground, preferably concrete.
- ✗ **DO NOT** use the creeper for any purpose other than that for which is designed.
- ✗ **DO NOT** stand on the creeper.
- ✗ **DO NOT** get the creeper wet or use in damp or wet locations or areas where there is condensation.
- ✗ **DO NOT** clean the creeper with any solvents which may damage the paint surface or padded areas.

## 2. INTRODUCTION

Powder coated tubular steel construction with padded vinyl cushions. Super-stable design with seven smooth-rolling Ø63mm ball-bearing swivel castors. Converts to seat mode in seconds. 180kg Capacity in creeper mode and 130kg capacity in seat mode.

## 3. SPECIFICATION

<b>MODEL NO:</b>	<b>SCR791</b>
Capacity	180kg creeper mode and 130kg in seat mode.
Nett Weight	5.8kg
Wheels	6 x Ø50mm

## 4. ASSEMBLY

Refer to Parts fig.1

- 4.1. **ATTACH ASSEMBLIES 1,2,3.**
- 4.1.1. Using bolts (11) washers (7) and nuts (12) assembly all three pre-built sections (1,2,3).
- 4.2. **ATTACH THE REMAINING 4 CASTOR WHEELS**
- 4.2.1. Fix the remaining 4 castor wheels (8) to the creeper frame using grub screws (13) and washers (14) shown fig.1.

## 5. OPERATION

- WARNING!** If you raise the vehicle to work under it, set the vehicle on jack stands.
- ✗ **DO NOT** work under a vehicle raised on a jack(s).
- 5.1. If the vehicle is on the ground, block the tyres, apply the handbrake and put it into gear or Park mode.
- 5.2. As you slide under the vehicle and prior to sliding out on the creeper, keep your head flat on the headrest.
- 5.3. If storing the creeper vertically, store near a wall and with the cushions facing the wall.

## 6. MAINTENANCE

- 6.1. Before each use inspect the overall condition of the creeper for broken, cracked or bent parts that may effect the proper operation.
- 6.2. Periodically check tightness of fixings.

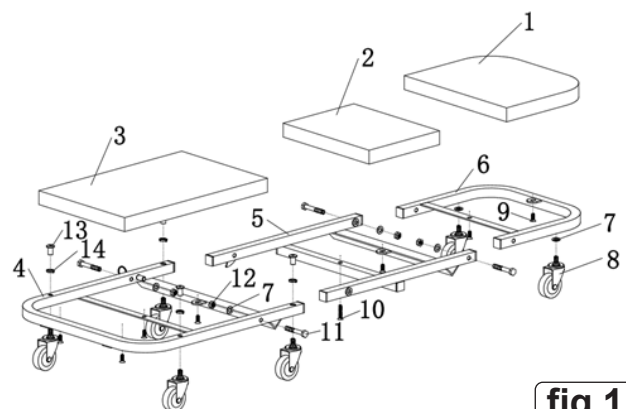
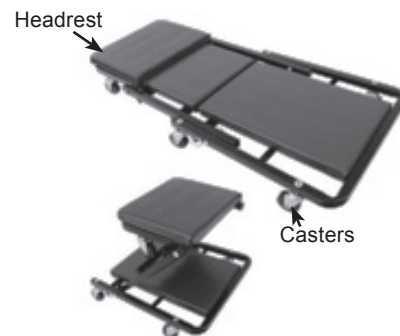

fig.1



#### ENVIRONMENT PROTECTION

Recycle unwanted materials instead of disposing of them as waste. All tools, accessories and packaging should be sorted, taken to a recycling centre and disposed of in a manner which is compatible with the environment. When the product becomes completely unserviceable and requires disposal, drain any fluids (if applicable) into approved containers and dispose of the product and fluids according to local regulations.



REGISTER YOUR  
PURCHASE HERE

**Note:** It is our policy to continually improve products and as such we reserve the right to alter data, specifications and component parts without prior notice.

**Important:** No Liability is accepted for incorrect use of this product.

**Warranty:** Guarantee is 12 months from purchase date, proof of which is required for any claim.

Sealey Group, Kempson Way, Suffolk Business Park, Bury St Edmunds, Suffolk. IP32 7AR



01284 757500



sales@sealey.co.uk



www.sealey.co.uk