



INSTRUCTIONS FOR:
FOLDING WORKSHOP CRANE
1 TONNE 'KD' TYPE
 MODEL No: **SC10.V3**

Thank you for purchasing a Sealey product. Manufactured to a high standard, this product will, if used according to these instructions, and properly maintained, give you years of trouble free performance.

IMPORTANT: PLEASE READ THESE INSTRUCTIONS CAREFULLY. NOTE THE SAFE OPERATIONAL REQUIREMENTS, WARNINGS & CAUTIONS. USE THE PRODUCT CORRECTLY AND WITH CARE FOR THE PURPOSE FOR WHICH IT IS INTENDED. FAILURE TO DO SO MAY CAUSE DAMAGE AND/OR PERSONAL INJURY AND WILL INVALIDATE THE WARRANTY. KEEP THESE INSTRUCTIONS SAFE FOR FUTURE USE.



Refer to instruction manual



Wear protective footwear



Wear protective gloves

1. CONTENTS

	Page No.
Section 2. General	1.
Section 2.1 Identification	1.
Section 2.2. Technical Data.	1.
Section 3. Safety/Operational Instructions.	2.
Section 4. Maintenance/Examination/Inspection.	2.
Section 5. Assembly and Storage.	3.
Section 6. Owner's & Operator's Responsibilities.	3.

2. GENERAL

2.1 IDENTIFICATION

Supplier: Sealey Power Products,
 Kempson Way,
 Suffolk Business Park,
 Bury St Edmunds,
 Suffolk, IP32 7AR.

Model No: SC10.V3

2.2 TECHNICAL DATA

2.2.1 Rated Capacity

Safe Working Load (SWL) 1t (tested to 50% overload).

Lifting Cap. in Position 1:	1000kg
Lifting Cap. in Position 2:	750kg
Lifting Cap. in Position 3:	500kg
Lifting Cap. in Position 4:	250kg
Weight:	77kg

2.2.2 Design Capability: Test Load 50% overload.

2.2.3 For a description of in-service and out-of-service conditions see Section 3 Safety, Section 4 Maintenance and Section 6 Owner's & Operator's Responsibilities.

2.2.4 The crane is fitted with a bypass valve that will prevent the ram from over extending.

2.2.5 For applications see Section 3 Safety.

2.2.6 For control system, see fig.2 for release valve, pump assembly and handle. Operation is explained in Section 3.2.

2.2.7 For ground condition requirements, see Section 3 Safety.

2.2.8 For information on parts and materials requiring specialised repair techniques see Section 4 Maintenance.



fig.1

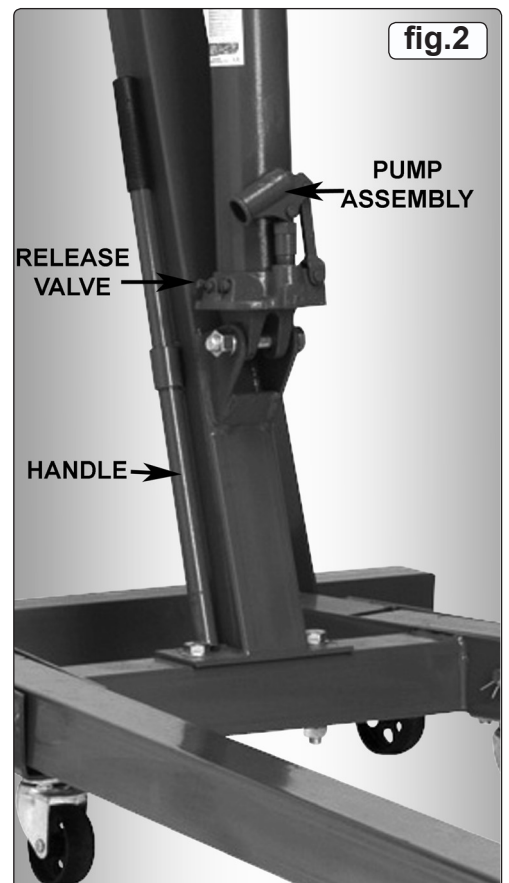

fig.2

PUMP ASSEMBLY

RELEASE VALVE

HANDLE

3. SAFETY/OPERATING INSTRUCTIONS

3.1 SAFETY

- ✓ Keep crane, lifting slings, support and beams in good working order and condition. Follow the inspection requirements as described in Section 4 Maintenance. *Take immediate action to repair or replace damaged parts by contacting your supplier.*
- ✓ *Ensure that all accessory lifting devices are suitably certified. If crane is damaged, remove from service immediately.*
- ✓ **Ensure the surface on which the crane is used is level, firm and capable of supporting the weight of the crane with maximum load - we recommend concrete. Never use the crane on tarmac or other soft surfaces.**
- ✓ Ensure the crane legs and jib extension are locked before use.
- ✓ Keep children and unauthorised persons away from the working area.
- ✓ Keep working area clean and tidy, free from unrelated materials and ensure that there is adequate lighting.
- ✓ Ensure that load does not exceed the maximum lifting capacity of the crane. Overloading the crane is dangerous. Where appropriate use only the lifting points recommended by the manufacturer of the item to be lifted, e.g. vehicle engine.
- ✓ Before lifting the load ensure that the crane jib is in the lowest practical position, that there are no obstacles which may snag the load whilst it is being lifted and that the area above the jib is clear.
- ✓ To avoid injury, be fully aware of your own and other persons locations in relation to the lifting and lowering of the load.
- ✓ Keep a sound footing and balance and ensure the floor is not slippery.
- ✓ Ensure jib extension locking bolt and nut are in position before lifting.
- ✓ Ensure the centre of gravity always remains inside the crane base.
- X **DO NOT** harness the load at an angle or use any attachments not verified as fit for purpose.
- X **DO NOT** allow the load to swing during lifting.
- X **DO NOT** allow the load to drop suddenly. Lower load with care, ensuring that you are fully aware of the condition of the surface onto which the load is to be placed.
- X **DO NOT** load crane beyond its rated capacity for each specified jib extension position as indicated in Section 2. The capacity of the crane reduces as the jib is extended.
- X **DO NOT** position any part of your body beneath the load.
- X **DO NOT** use the crane to move, or transport, a load other than for repositioning (see 3.2.6). The crane is a lifting device only.
- X **DO NOT** apply any sideways pressure to any part of the crane during lifting or when a load is suspended.
- X **DO NOT** attempt to adjust the safety valve, which has been set and sealed by the manufacturer.
- X **DO NOT** use this product to perform a task for which it is not designed.
- X **DO NOT** use the crane whilst tired or under the influence of drugs, alcohol or intoxicating medication.
- X **DO NOT** climb on the crane.
- ✓ When not in use, fold the crane down and store in a safe, dry, childproof area.
- ✓ **This crane is designed for lifting within a garage or workshop environment.**
- ☐ **WARNING! Failure to heed safety and warning instructions may result in damage and/or personal injury and will invalidate the warranty.**

3.2 OPERATION (Refer to Section 4.2 regarding inspection before each and every use)

NOTE: ENSURE YOU HAVE READ AND UNDERSTOOD THE SAFETY INSTRUCTIONS AT THE BEGINNING OF THIS SECTION BEFORE YOU OPERATE THE CRANE.

- 3.2.1 Use the pump handle recess to tighten the release valve, turning firmly clockwise.
- 3.2.2 Place handle into pump socket and pump, the jib will raise. Continue to pump until the jib reaches the height at which the load can be secured.
- 3.2.3 Connect the crane hook to the load using a suitable **certified** sling or support beam. Ensure you are aware of the load weight, and check that it is within the capacity of the crane (at the jib extension you are using) and the sling or support beam. When removing engines ensure you know the weight to be lifted. Use only the lifting points recommended by the vehicle manufacturer.
- 3.2.4 Lift only from directly above the load. **DO NOT LIFT THE LOAD AT AN ANGLE!**
- 3.2.5 To lower load, position handle on release valve at base of ram and turn **VERY SLOWLY anti-clockwise** avoiding any sudden movement. **DO NOT** allow the load to drop suddenly.
- 3.2.6 The crane is not a transportation device but may be used to reposition the load being worked on. To do so, lower load and jib with care, to the lowest possible point before attempting to move. **DO NOT** try to move crane in a sideways direction. The crane is not designed to support the load indefinitely. When you have repositioned the load, lower the load onto a secure and appropriate working base, being fully aware of your own and other persons locations in relation to the lowering load.
- 3.2.7 When load has been secured, remove lifting sling, support beam etc. and place crane in a safe location with the jib fully lowered.

4. MAINTENANCE/EXAMINATION/INSPECTION

NOTE: The crane MUST be kept clean and dry and maintained in accordance with these instructions.

4.1 LUBRICATION

- 4.1.1 Oil all working parts monthly.
- 4.1.2 The ram is filled with hydraulic oil and should only require occasional topping up. For the occasional top up **DO NOT** use brake fluid, as this will damage the hydraulic seals.
- 4.1.3 Use only good quality hydraulic jack oil (Sealey Part No: HJO500MLS or HJO5LS). **DO NOT OVERFILL.**
- 4.1.4 After filling with hydraulic oil, check the crane for operation and purge any air from the system as required (See 5.1.9).

4.2 INSPECTION AND EXAMINATION OF CRANE BEFORE USE

- 4.2.1 Before each use of the crane you must perform an inspection for leaks, damage and loose or missing parts.
- 4.2.2 The workshop crane must be examined immediately if it has been subject to an abnormal load or shock. It is recommended that such an examination is made by an authorised service agent.
- 4.2.3 The owner and/or operator must be aware that repair of this equipment will require specialised knowledge and facilities.
- 4.2.4 It is recommended that an annual examination of the workshop crane is made by an authorised service agent.
- 4.2.5 Unauthorised parts may be dangerous and will invalidate the warranty.

NOTE: Please see the Definition of 'INSPECTION' and 'EXAMINATION' below.

INSPECTION:

Looking at the crane for defects and checking the operation of the controls, limiting and indicating devices without loading the crane. This is much more than a check but does not normally require any part of the crane to be dismantled other than removal or opening of covers or housings.

EXAMINATION:

Verification that the crane can safely continue in service including a functional test of all safety devices i.e. limiting, indicating equipment, brakes, clutches, safety valves etc. to verify that they operate within the required tolerances. An examination is more thorough than an inspection.

5. ASSEMBLY/STORAGE INSTRUCTIONS

5.1 ASSEMBLY

- 5.1.1 Unpack the product and check contents against the parts list included with these instructions. Should there be any damaged or missing parts contact your supplier immediately. We recommend two people assemble the crane.
 - 5.1.2 Lay out all the parts in the appropriate positions ready for assembly.
 - 5.1.3 When assembling, ensure that you fit a plain washer, then a locking washer before fitting nuts on to bolts.
 - 5.1.4 Assemble the crane main frame first, leaving the hydraulic ram assembly until last.
- NOTE:** At this stage all nuts and bolts should be finger tight only.
- 5.1.5 Connect the base of the ram assembly to the ram assembly mounting.
 - 5.1.6 Raise the lift arm and carefully move it until the ram fits the arm bracket. Engage the pin and secure with the fasteners provided.
 - 5.1.7 Now tighten all the nuts and bolts on the main frame.
 - 5.1.8 Assemble and insert the legs and locate with the lock pins provided.
 - 5.1.9 Before using crane place the pumping handle on the release valve and turn anti-clockwise. With the handle inserted in the pump socket, pump 20 times through the full stroke, thus bleeding from the hydraulic system any air which may have entered during transit.

5.2 STORAGE

- 5.2.1 Always store the crane fully closed so that the jib is in lowest position and the ram is closed (fig.3).
- 5.2.2 To save space the legs may be folded into the upright position and secured in place using the lock pins (fig.3).

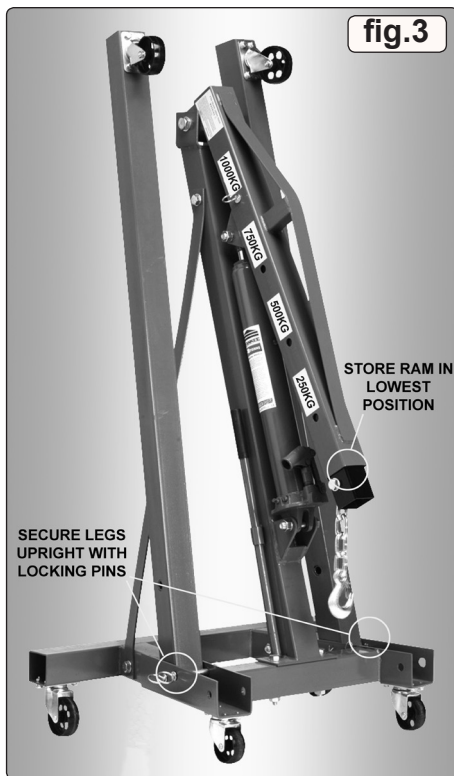

6. OWNER'S & OPERATOR'S RESPONSIBILITIES

NOTE: THE OWNER AND/OR OPERATOR MUST STUDY THESE INSTRUCTIONS AND RETAIN THEM FOR FUTURE USE.

6.1 UNDERSTANDING INSTRUCTIONS AND WARNINGS

- 6.1.1 The owner and/or operator shall understand the operating instructions and warnings before operating the crane. Warning information must be emphasised and understood. If the operator is not fluent in English, the product instructions and warnings must be read to, and discussed with the operator in the operator's native language by the owner making sure the operator understands the contents.

6.2 DAMAGED CRANES

- 6.2.1 Any crane which appears to be damaged, badly worn, or operates abnormally **MUST BE REMOVED FROM SERVICE!** It is recommended that necessary repairs be made by an authorised service agent.

6.3 END OF SERVICE

- 6.3.1 Through years of normal wear and tear, the crane may eventually become unserviceable. When this happens ensure the hydraulic oil is drained off and disposed of in accordance with local authority regulations.

NOTE: It is our policy to continually improve products and as such we reserve the right to alter data, specifications and component parts without prior notice.

IMPORTANT: No liability is accepted for incorrect use of this product.

WARRANTY: Guarantee is 12 months from purchase date, proof of which will be required for any claim.



Sole UK Distributor, Sealey Group,
Kempson Way, Suffolk Business Park,
Bury St. Edmunds, Suffolk,
IP32 7AR



01284 757500

01284 703534



www.sealey.co.uk

sales@sealey.co.uk