



## INSTRUCTIONS FOR

# VARIABLE SPEED BELT SANDER 400W/230V

MODEL NO: **SBS35**

Thank you for purchasing a Sealey product. Manufactured to a high standard, this product will, if used according to these instructions, and properly maintained, give you years of trouble free performance.

**IMPORTANT:** PLEASE READ THESE INSTRUCTIONS CAREFULLY. NOTE THE SAFE OPERATIONAL REQUIREMENTS, WARNINGS & CAUTIONS. USE THE PRODUCT CORRECTLY AND WITH CARE FOR THE PURPOSE FOR WHICH IT IS INTENDED. FAILURE TO DO SO MAY CAUSE DAMAGE AND/OR PERSONAL INJURY AND WILL INVALIDATE THE WARRANTY. KEEP THESE INSTRUCTIONS SAFE FOR FUTURE USE.



Refer to instructions



Wear eye protection



Wear protective gloves



Wear safety footwear



Wear protective clothing



Wear ear protection



Wear a mask

## 1. SAFETY

### 1.1. ELECTRICAL SAFETY

- WARNING!** It is the responsibility of the owner and the operator to read, understand and comply with the following: You must check all electrical products, before use, to ensure that they are safe. You must inspect power cables, plugs, sockets and any other connectors for wear or damage. You must ensure that the risk of electric shock is minimised by the installation of appropriate safety devices. A Residual Current Circuit Breaker (RCCB) should be incorporated in the main distribution board. We also recommend that a Residual Current Device (RCD) is used. It is particularly important to use an RCD with portable products that are plugged into a supply which is not protected by an RCCB. If in any doubt consult a qualified electrician. You may obtain a Residual Current Device by contacting your Sealey dealer.  
You must also read and understand the following instructions concerning electrical safety.
- ✓ The Electricity at Work Act 1989 requires that all portable electrical appliances, if used on business premises, are tested by a qualified electrician, using a Portable Appliance Tester (PAT), at least once a year.
- ✓ The Health & Safety at Work Act 1974 makes owners of electrical appliances responsible for the safe condition of those appliances and the safety of the appliance operators. If in any doubt about electrical safety, contact a qualified electrician.
- ✓ Ensure that the insulation on all cables and on the appliance is safe before connecting it to the power supply.
- ✓ Insure that cables are always protected against short circuit and overload.
- ✓ Regularly inspect power supply cables and plugs for wear or damage and check all connections to ensure that none are loose.
- ✓ Important: Ensure that the voltage marked on the appliance matches the power supply to be used and that the plug is fitted with the Correct fuse - see fuse rating at right.
- ✗ **DO NOT** pull or carry the appliance by the power cable.
- ✗ **DO NOT** pull the plug from the socket by the cable.
- ✗ **DO NOT** use worn or damaged cables, plugs or connectors. Immediately have any faulty item repaired or replaced by a qualified electrician. When a BS 1363/A UK 3 pin plug is damaged, cut the cable just above the plug and dispose of the plug safely. Fit a new plug according to the following instructions (UK only).
  - a) Connect the GREEN/YELLOW earth wire to the earth terminal 'E'.
  - b) Connect the BROWN live wire to the live terminal 'L'.
  - c) Connect the BLUE neutral wire to the neutral terminal 'N'.
- ✓ After wiring, check that there are no bare wires, that all wires have been correctly connected, that the cable outer insulation extends beyond the cable restraint and that the restraint is tight. Double insulated products, which are always marked with this symbol, are fitted with live (brown) and neutral (blue) wires only. To rewire, connect the wires as indicated above - **DO NOT** connect either wire to the earth terminal.
- ✓ Products which require more than 5 amps are supplied without a plug. In this case you must contact a qualified electrician to ensure that a suitably rated supply is available. We recommend that you discuss the installation of an industrial round pin plug and socket with your electrician.

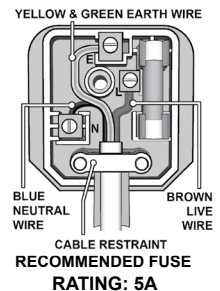

### 1.2. GENERAL SAFETY

- WARNING!** Ensure Health & Safety, local authority and general workshop practice regulations are adhered to when using this equipment.
- WARNING!** Disconnect from mains power before changing accessories, servicing or maintenance.
- ✓ Maintain the sander in good condition (use an authorised service agent).
- ✓ Replace or repair damaged parts. Use recommended parts only. Unauthorised parts may be dangerous and will invalidate the warranty.
- ✓ Use sander in a suitable working area. Keep area clean, tidy and free from unrelated materials. Ensure there is adequate lighting.
- ✓ Before use check sanding belt. If worn or damaged replace immediately.
- WARNING!** Always wear approved eye or face protection when operating the sander.
- ✓ If dust is generated, use face, dust, or respiratory protection in accordance with COSHH regulations.
- ✓ Depending on task, sander noise level may exceed 85dB in which case wear safety ear defenders.
- ✓ Remove ill fitting clothing, ties, watches, rings, other loose jewellery and contain and/or tie back long hair.
- ✓ Wear appropriate protective clothing and keep hands and body clear of the sanders working parts.

- ✓ Maintain correct balance and footing. Ensure the floor is not slippery and wear non-slip shoes.
- ✓ Keep children and unauthorised persons away from the work area.
- ✓ Check moving parts alignment on a regular basis.
- ✓ Ensure the work piece is correctly secured before operating the sander. Never hold work piece by hand and check the work piece to ensure there are no protruding nails, screws, stones, etc.
- ✓ Avoid unintentional starting.
- ✗ **DO NOT** force the sander to achieve a task it was not designed to perform.
- ✗ **DO NOT** operate sander if any parts are damaged or missing. This may cause failure or possible injury.
- ☐ **WARNING! DO NOT** sand any materials containing asbestos.
- ✗ **DO NOT** carry the sander by the electrical cable or dust extraction hose.
- ✗ **DO NOT** get the sander wet or use in damp or wet locations.
- ✗ **DO NOT** use these models with water, these models are dry sanders only.
- ✗ **DO NOT** operate sander if you are tired, under the influence of alcohol, drugs or intoxicating medication.
- ✗ **DO NOT** use where there is flammable liquids, solids or gases such as paint solvents, including waste wiping or cleaning rags etc.
- ✗ **DO NOT** carry the sander with your finger on the power switch.
- ✓ When not in use disconnect from the mains power supply and dust free system and store in a safe, dry, childproof area.
- ☐ **WARNING! DO NOT** allow uncontrolled discharge of dust waste thus polluting the environment.
- ☐ **WARNING! LEAD PAINT.**  
Paint once contained lead as a traditional ingredient. The dust from the removal of such paint is toxic if ingested/inhaled and must, therefore, be avoided. The following actions must be taken before using the sander on a surface that you suspect may contain lead paint.
  1. User must determine potential hazard relating to age of paint to be removed. (Modern paints do not have lead content).
  2. **DANGER!** Keep all persons and pets away from the work area. The following persons are particularly vulnerable to the effects of lead paint dust: Expectant women, babies and children.
  3. We recommend personal protection by using the following safety items:
    - a) Paint Spray Respirator (Sealey ref. SSP16EN)
    - b) PE Coated Hooded Coverall (Sealey ref. SSP266).
    - c) Latex Gloves (Sealey ref. SSP24).
  4. Take adequate measures to contain the paint dust, flakes and scrapings.
  5. Continue to wear safety equipment as in (3) above and thoroughly clean all areas when task is complete. Ensure paint waste is disposed of in sealed bags or containers.
- ☐ **WARNING! – Risk of Hand Arm Vibration Injury.**  
This tool may cause Hand Arm Vibration Syndrome if its use is not managed adequately.  
This tool is subject to the vibration testing section of the Machinery Directive 2006/42/EC.  
This tool is to be operated in accordance with these instructions.

Measured vibration emission value (a): .....3.8 m/s<sup>2</sup>

Uncertainty value (k):..... 1.5 m/s<sup>2</sup>

Please note that the application of the tool to a sole specialist task may produce a different average vibration emission.

We recommend that a specific evaluation of the vibration emission is conducted prior to commencing with a specialist task.

A health and safety assessment by the user (or employer) will need to be carried out to determine the suitable duration of use for each tool. NB: Stated Vibration Emission values are type-test values and are intended to be typical.

Whilst in use, the actual value will vary considerably from and depend on many factors.

Such factors include; the operator, the task and the inserted tool or consumable.

NB: ensure that the length of leader hoses is sufficient to allow unrestricted use, as this also helps to reduce vibration.

The state of maintenance of the tool itself is also an important factor, a poorly maintained tool will also increase the risk of Hand Arm Vibration Syndrome.

Health surveillance.

We recommend a programme of health surveillance to detect early symptoms of vibration injury so that management procedures can be modified accordingly.

Personal protective equipment.

We are not aware of any personal protective equipment (PPE) that provides protection against vibration injury that may result from the uncontrolled use of this tool. We recommend a sufficient supply of clothing (including gloves) to enable the operator to remain warm and dry and maintain good blood circulation in fingers etc. Please note that the most effective protection is prevention, please refer to the Correct Use and Maintenance section in these instructions. Guidance relating to the management of hand arm vibration can be found on the HSC website [www.hse.gov.uk](http://www.hse.gov.uk) - Hand-Arm Vibration at Work.

## 2. INTRODUCTION

Ideal for use in Body shops, sanding otherwise inaccessible areas, such as around door shuts. Features three different sanding arms to suit the working area. Self-contained dust collection bag to fit exhaust. Six speed power control. Belt tension release lever for simple removal/replacement. Supplied in tough storage/carry case.

## 3. SPECIFICATION

Model No.....SBS35  
 Belt..... 6 x 456mm, 12 x 456mm  
 Motor Power.....400W  
 Supply.....230V  
 No Load Speed ..... 1070-1650rpm  
 Weight..... 1.45kg  
 Vibration level ..... 3.8m/s<sup>2</sup>  
 Uncertainty..... 1.5m/s<sup>2</sup>

## 4. PREPARATION

- 4.1. Attach one of the three assorted arms (fig.1), do this by taking the spring provided and placing it into the circular recess on the grinders fixed arm.
- 4.2. Fit the arm as in fig.2, insert and tighten the thumb screw (fig.2C) through the arm and adjust as necessary to make a straight fit.
- 4.3. Push the arm retraction lever (fig.2B, fig.3D) forward, this will shorten the length of the arm to make it easier to apply a sanding belt, pull the lever back to tighten the belt.
- 4.4. Attach the dust collector to the exhaust (fig.3C) squeeze the two metal hooks together, this will enlarge the rim of the dust bag to fit over the exhaust.
- 4.5. **Belt Preparation**  
To ensure full flexibility, and to prolong working life, the belt must be "bedded in"
  - 4.5.1. Fit new belt ensuring the direction of travel is correct, and the belt join is NOT on the nose roller. Tension belt.
  - 4.5.2. Operate the tool without a load applied at half speed for around 10 seconds, then increase to full speed for a further 10 seconds.
  - 4.5.3. Finally, at a slow operating speed, using a piece of scrap material, apply light pressure to the belt where it runs over the "shoe". Increase the operating speed steadily to maximum for a few seconds, then stop.

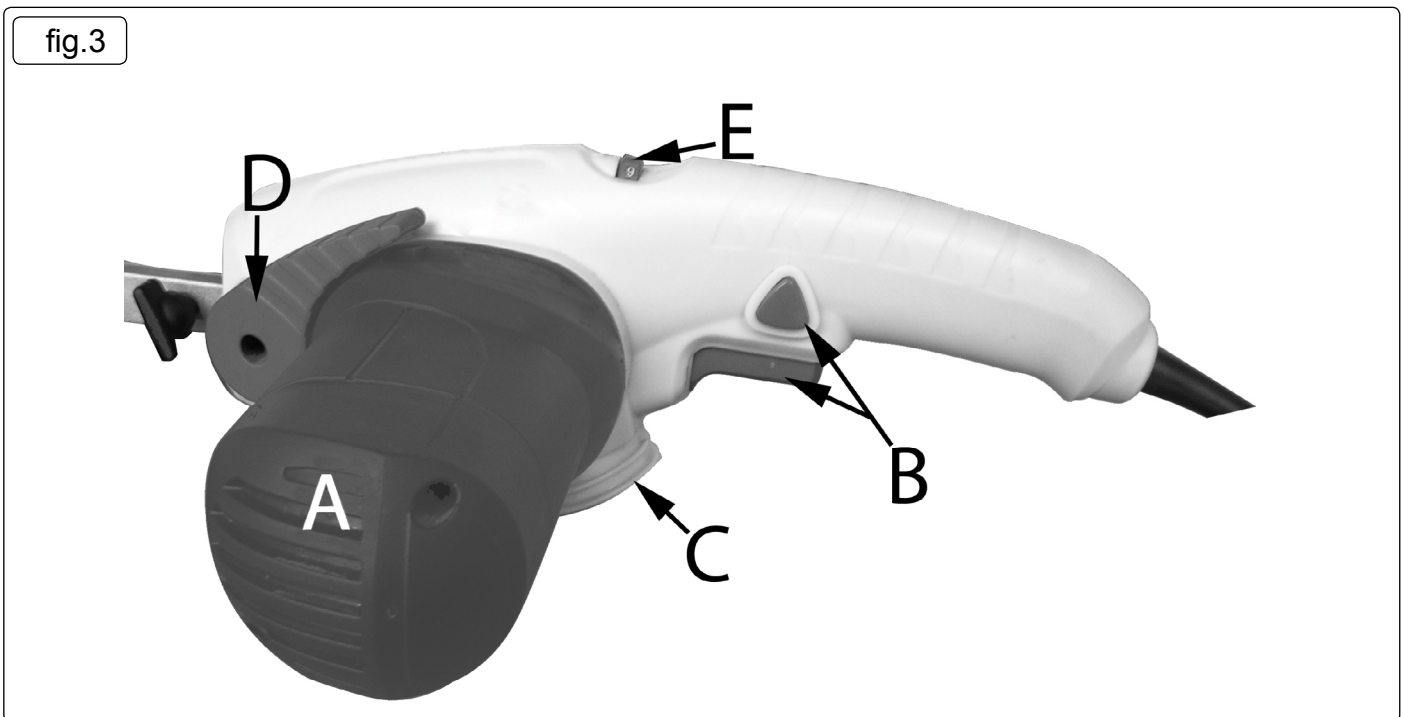
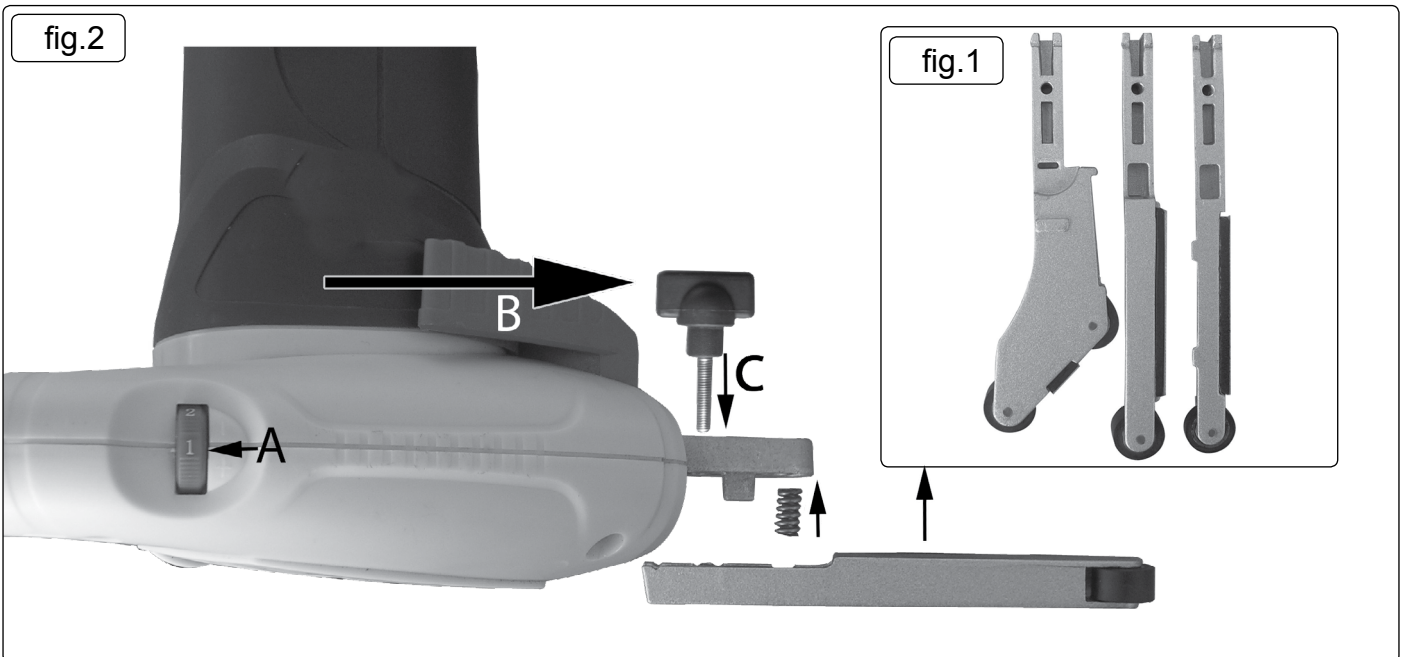

## 5. OPERATION

- 4.1 After completing steps in section 4 make sure that the sander is at the lowest speed setting and plug it into the mains power supply.
- 4.2 Hold in the trigger safety lock in and squeeze the trigger (fig.3B), adjust the speed with the scroll switch (fig.3E)
- 4.3 When finished release the trigger to stop the sander.
- 4.4 To change sanding belt, push the lever (fig.2B, fig.3D) forward, this will shorten the length of the arm and loosen the sanding belt. Slide the old belt off and replace with the same size belt. Pull the lever (fig.2B, fig.3D) back to tighten the belt. To change the arm and belt repeat from 4.1 "PREPARING FOR USE"

## 6. MAINTENANCE

- **WARNING!** Disconnect sander from mains power supply before changing accessories, servicing or performing maintenance. Replace or repair damaged parts. Use recommended parts only. Unauthorised parts may be dangerous and will invalidate the warranty.
- 6.1. Clean the underside of the sander after use. Use an air line to blow dust out from around the motor by passing the air through the ventilation holes.
- 6.2. Change belts when required.
- 6.3. Check brushes after every 200 hours of use. To do so remove the screws at end of the motor cover and remove the tip of the cover (fig.3A), remove the brass brush holder electrical connection, remove the brush holder and examine the carbon bush. Change brushes when they are only 5mm in length. Ensure unit is correctly re-assembled.
- 6.4. All other service and maintenance must be carried out by an authorised service agent.
- 6.5. When not in use store in a safe, dry, childproof location.

**Parts support is available for this product. To obtain a parts listing and/or diagram, please log on to [www.sealey.co.uk](http://www.sealey.co.uk), email [sales@sealey.co.uk](mailto:sales@sealey.co.uk) or telephone 01284 757500.**



### Environmental Protection

Recycle unwanted materials instead of disposing of them as waste. All tools, accessories and packaging should be sorted, taken to a recycling centre and disposed of in a manner which is compatible with the environment. When the product becomes completely unserviceable and requires disposal, drain off any fluids (if applicable) into approved containers and dispose of the product and the fluids according to local regulations.



### WEEE Regulations

Dispose of this product at the end of its working life in compliance with the EU Directive on Waste Electrical and Electronic Equipment (WEEE). When the product is no longer required, it must be disposed of in an environmentally protective way. Contact your local solid waste authority for recycling information.

**NOTE:** It is our policy to continually improve products and as such we reserve the right to alter data, specifications and component parts without prior notice.

**IMPORTANT:** No liability is accepted for incorrect use of this product.

**WARRANTY:** Guarantee is 12 months from purchase date, proof of which will be required for any claim.



Sole UK Distributor, Sealey Group.  
Kempson Way, Suffolk Business Park,  
Bury St. Edmunds, Suffolk.  
IP32 7AR



01284 757500



01284 703534



[www.sealey.co.uk](http://www.sealey.co.uk)



[sales@sealey.co.uk](mailto:sales@sealey.co.uk)