



INSTRUCTIONS FOR

VARIABLE SPEED BELT SANDER 260W

MODEL NO: **SBS260**

Thank you for purchasing a Sealey product. Manufactured to a high standard, this product will, if used according to these instructions, and properly maintained, give you years of trouble free performance.

IMPORTANT: PLEASE READ THESE INSTRUCTIONS CAREFULLY. NOTE THE SAFE OPERATIONAL REQUIREMENTS, WARNINGS & CAUTIONS. USE THE PRODUCT CORRECTLY AND WITH CARE FOR THE PURPOSE FOR WHICH IT IS INTENDED. FAILURE TO DO SO MAY CAUSE DAMAGE AND/OR PERSONAL INJURY AND WILL INVALIDATE THE WARRANTY. KEEP THESE INSTRUCTIONS SAFE FOR FUTURE USE.



Refer to instructions



Wear eye protection



Wear protective gloves



Wear safety footwear



Wear protective clothing



Wear ear protection



Wear a mask

1. SAFETY

1.1. Electrical Safety

- WARNING!** It is the user's responsibility to check the following:
 - Check all electrical equipment and appliances to ensure that they are safe before using. Inspect power supply leads, plugs and all electrical connections for wear and damage. Sealey recommend that an RCD (Residual Current Device) is used with all electrical products. You may obtain an RCD by contacting your local Sealey dealer.
 - If the sander is used in the course of business duties, it must be maintained in a safe condition and routinely PAT (Portable Appliance Test) tested.
- Electrical safety information, it is important that the following information is read and understood
- ✓ Ensure that the insulation on all cables and on the appliance is safe before connecting it to the power supply.
- ✓ Regularly inspect power supply cables and plugs for wear or damage and check all connections to ensure that they are secure
- ✓ **Important:** Ensure that the voltage rating on the appliance suits the power supply to be used and that the plug is fitted with the correct fuse - see fuse rating in these instructions.
- ✗ **DO NOT** pull or carry the appliance by the power cable.
- ✗ **DO NOT** pull the plug from the socket by the cable. Remove the plug from the socket by maintaining a firm grip on the plug.
- ✗ **DO NOT** use worn or damaged cables, plugs or connectors. Ensure that any faulty item is repaired or replaced immediately by a qualified electrician.
- ✓ This product is fitted with a BS1363/A 13 Amp 3 pin plug.
 - If the cable or plug is damaged during use, switch the electricity supply and remove from use.
 - Replace a damaged plug with a BS1363/A 13 Amp 3 pin plug. If in doubt contact a qualified electrician.
 - Class II products are wired with live (brown) and neutral (blue) only are marked with the Class II symbol;
 - A) Connect the BROWN live wire to the live terminal 'L'.
 - B) Connect the BLUE neutral wire to the neutral terminal 'N'.
 - C) After wiring, check that there are no bare wires and ensure that all wires have been correctly connected.
- Ensure that the cable outer sheath extends inside the cable restraint and that the restraint is tight.
- DO NOT** connect either wire to the earth terminal.
- Sealey recommend that repairs are carried out by a qualified electrician.

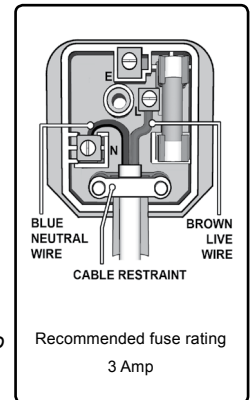

1.2. General Safety

- WARNING!** Ensure Health & Safety, local authority, and general workshop practice regulations are adhered to when using this equipment.
- WARNING!** Disconnect from power supply before changing accessories or servicing.
- ✓ Maintain the sander in good condition (use an authorised service agent).
- ✓ Replace or repair damaged parts. Use genuine parts only. Unauthorised parts may be dangerous and will invalidate the warranty.
- ✓ Use in suitable clean and tidy working area, free from unrelated materials and ensure there is adequate lighting.
- ✓ Before each use check abrasive belt for condition. If worn or damaged replace immediately.
- ✓ Use only the correct size and type of sanding belt with this sander.
- ✓ Ensure there are no flammable or combustible materials near the work area.
- WARNING!** Always wear approved eye or face and hand protection when operating the sander. Use face, dust, or respiratory protection in accordance with COSHH regulations.
- ✓ Remove ill fitting clothing. Remove ties, watches, rings, other loose jewellery and contain and/or tie back long hair.
- ✓ Wear appropriate protective clothing and keep hands and body clear of working parts.
- ✓ Maintain correct balance and footing. Ensure the floor is not slippery and wear non-slip shoes.
- ✓ Keep children and unauthorised persons away from the work area.
- ✓ Check moving parts alignment on a regular basis.
- ✓ Ensure workpiece is secure before operating the sander. Never hold a work piece by hand.
- ✓ Check the work piece to ensure there are no protruding screws, bolts, nuts, nails, rivets, etc.
- ✓ Avoid unintentional starting.
- ✓ Keep power lead away from heat, oil and sharp edges.
- ✓ Prolonged exposure to vibration from this sander poses a health risk. It is the owner's responsibility to correctly assess the potential hazard and issue guidelines for safe periods of use and offer suitable protective equipment.

- × **DO NOT** use the sander for a task it is not designed to perform.
- × **DO NOT** operate sander if any parts are damaged or missing as this may cause failure and/or personal injury.
- ☐ **WARNING! DO NOT** sand any materials containing asbestos.
- × **DO NOT** force, or apply heavy pressure to, the sander, let the sander do the work.
- × **DO NOT** switch the sander on whilst the belt is in contact with the work piece.
- × **DO NOT** operate sander when you are tired or under the influence of alcohol, drugs or intoxicating medication.
- × **DO NOT** use sander where there are flammable liquids, solids or gases such as paint solvents and including waste wiping or cleaning rags etc.
- × **DO NOT** carry the sander with your finger on the power lever.
- ✓ When not in use store in a safe, dry, childproof location.

1.3. **Lead Paint Warning!**

Paint once contained lead as a traditional ingredient. The dust from the removal of such paint is toxic if ingested/inhaled and must, therefore, be avoided. The following actions must be taken before using the sander on a surface that you suspect may contain lead paint.

1. User must determine potential hazard relating to age of paint to be removed. (Modern paints do not have lead content).
2. **DANGER!** Keep all persons and pets away from the work area. The following persons are particularly vulnerable to the effects of lead paint dust: *Expectant women, babies and children.*
3. We recommend personal protection by using the following safety items:
 - a) Paint Spray Respirator (Sealey ref. SSP1699)
 - b) PE Coated Hooded Coverall (Sealey ref. SSP265-L).
 - c) Latex Gloves (Sealey ref. SSP24).
4. Take adequate measures to contain the paint dust, flakes and scrapings.
5. Continue to wear safety equipment as in (3) above and thoroughly clean all areas when task is complete. Ensure paint waste is disposed of in sealed bags or containers and according to local Authority guidelines.

2. INTRODUCTION

Compact lightweight design, ideal for use in body shops and reaching inaccessible areas. Sanding arm angle can be adjusted by up to 60° to achieve better access to intricate areas. Variable speed power control. Push to lock and release sanding arm for easy belt changing. Includes a detachable exhaust, making it use able with extraction systems.

3. SPECIFICATION

Model no: **SBS260**
 Belt size: 12 x 456mm
 Motor power: 260W
 Supply: 230V
 No load speed: 772-1200rpm
 Weight: 1.15kg

- 1. On/Off switch
- 2. Variable speed control knob
- 3. Handle
- 4. Angle lock screw
- 5. Belt tensioning button
- 6. Straight arm
- 7. Sanding belt
- 8. Dust extraction port

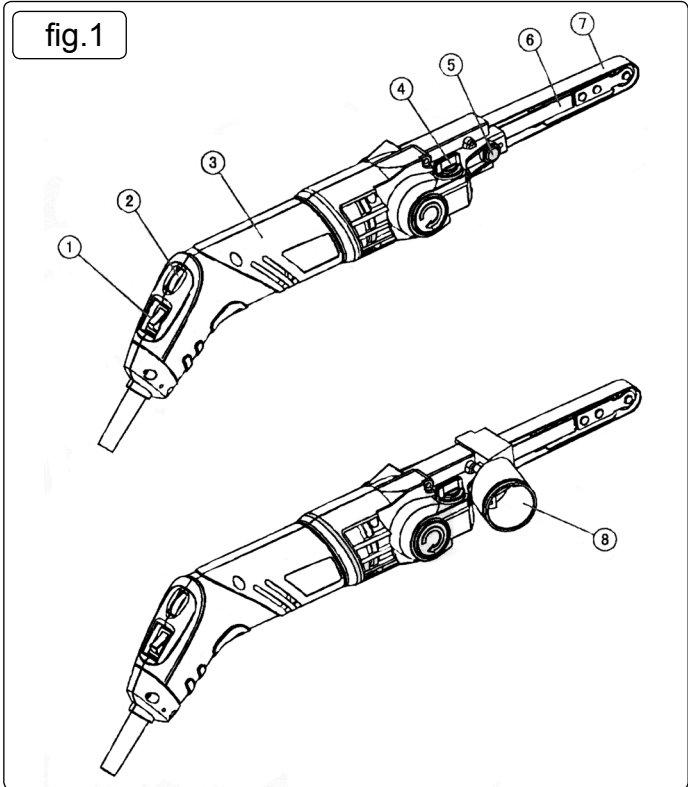

4. OPERATION

- 4.1. **Fitting and removing sanding belts refer to fig.1**
 - 4.1.1. Unplug the power lead before changing belts. Remove dust extraction port if fitted. Push the straight arm against a hard object, until it clicks into its retracted position, see fig.2A.
 - 4.1.2. Slide the belt onto the rollers, see fig.2B. Make sure the arrows on the inside of the belt face the same direction as those on the housing.
 - 4.1.3. Press the belt tensioning button, see fig.2.C and the belt will tighten.
 - 4.1.4. Removal of the belt is the reverse of instructions 4.1.1. to 4.1.3.
- 4.2. **Switching on and off**
 - 4.2.1. To switch on/off use switch, see fig.1-1.
- 4.3. **Variable speed control see fig.1-2**
 - 4.3.1. The variable speed control allows the speed to be matched to the material being worked on. Use a low speed when using a fine grit belt to work upon ceramics or plastics or when removing paint or varnish. Use a high speed, when using a coarse grit belt or when removing a lot of material.
 - 4.3.2. There are 6 speed settings 1 (low) to 6 (high).

4.4. Belt arm angle adjustment

- 4.4.1. Unplug the power lead. Loosen the angle lock screw, see fig.1-4 by turning it anticlockwise, see fig.3.
- 4.4.2. Pivot the belt arm, see fig.1-6, to the desired angle.
- 4.4.3. Tighten the angle lock screw, by turning it clockwise, see fig.3.

4.5. Connecting to a vacuum cleaner or dust collector

- 4.5.1. Remove the dust extraction port, see fig.1-8 when a dust collector or vacuum cleaner is not connected to the sander.

❑ **WARNING!** Never insert your finger into the nozzle.

- 4.5.2. Install the dust extraction port, see fig.1-8, onto the sander, see fig.4A. Make sure the extraction port has a firm grip on the sander.
- 4.5.3. Connect the hose of the vacuum/dust collector onto the dust extraction port. **Note:** the I/D of the hose is 32mm (1.25").

4.6. Belt Preparation

To ensure full flexibility, and to prolong working life, the belt must be "bedded in"

- 4.6.1. Fit new belt ensuring the direction of travel is correct, and the belt join is NOT on the nose roller. Tension belt.
- 4.6.2. Operate the tool without a load applied at half speed for around 10 seconds, then increase to full speed for a further 10 seconds.
- 4.6.3. Finally, at a slow operating speed, using a piece of scrap material, apply light pressure to the belt where it runs over the "shoe". Increase the operating speed steadily to maximum for a few seconds, then stop.

4.7. Sanding

- 4.7.1. Make sure the sander is not already touching the work piece when the sander is turned on or off, otherwise a poor sanding finish, damage to the belt or loss of control of the tool may result.

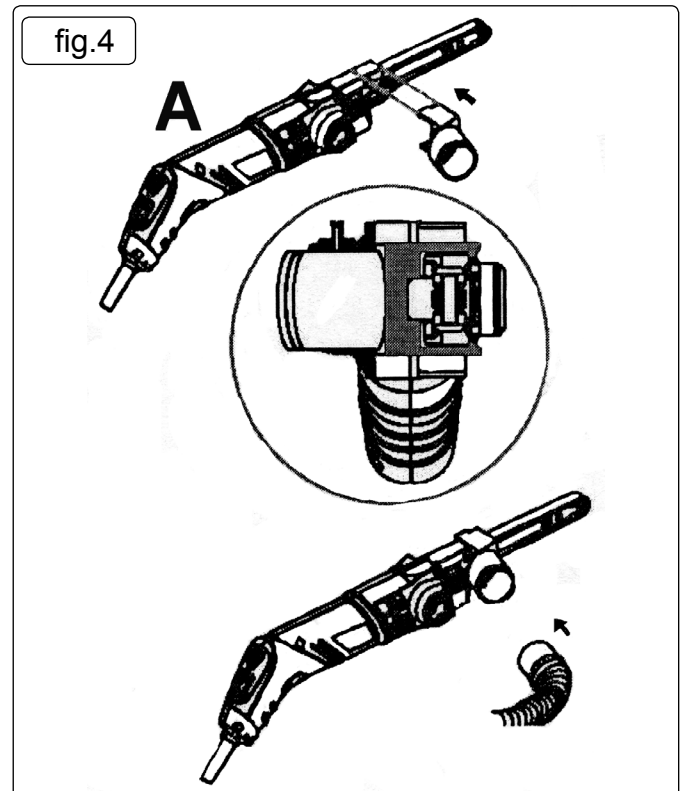
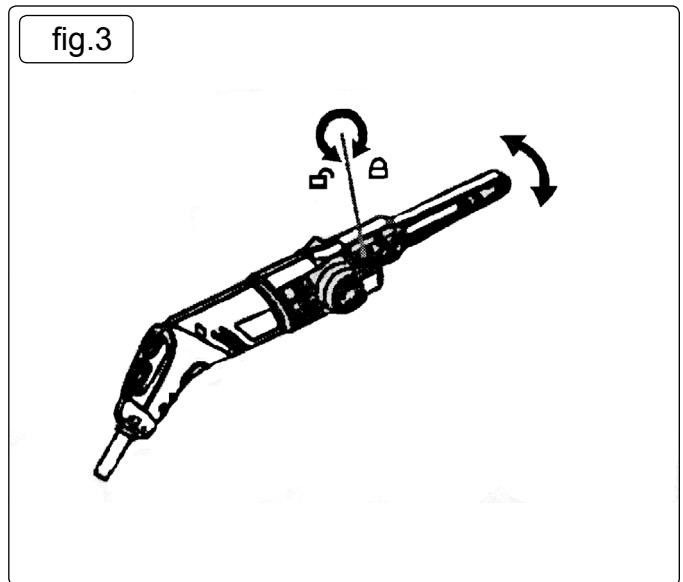
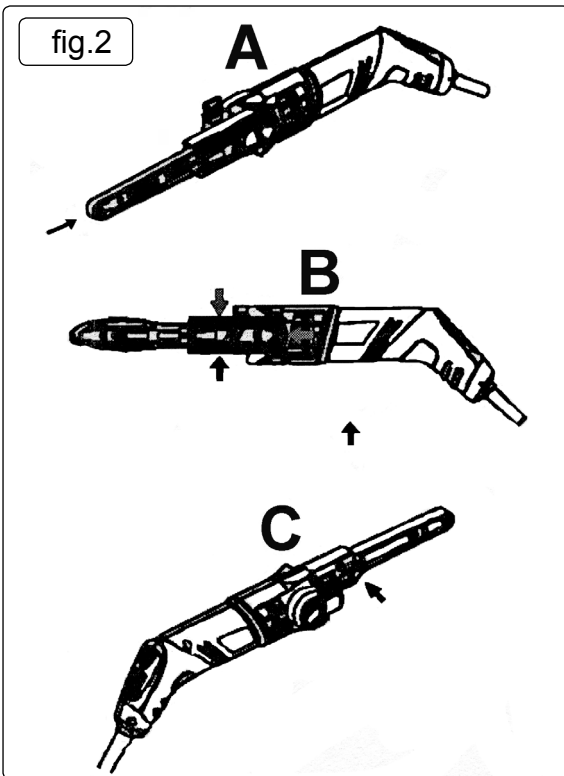

5. MAINTENANCE

- ❑ **WARNING!** Before performing any maintenance disconnect the sander from the power supply.
- 5.1. All maintenance should only be carried out by an authorised Sealey service agent.
- 5.2. **Cleaning**
 - 5.2.1. Blow clean with compressed air. Always wear eye protection and dusk masks when using compressed air to clean the sander.
 - 5.2.2. Ventilation holes and switch assemblies need to be kept clean.
 - 5.2.3. **DO NOT** use chemicals to clean the sander.
 - 5.2.4. When not in use clean and store in a safe, dry, childproof location.

Parts support is available for this product. To obtain a parts listing and/or diagram, please log on to www.sealey.co.uk, email sales@sealey.co.uk or telephone 01284 757500.



WEEE Regulations

Dispose of this product at the end of its working life in compliance with the EU Directive on Waste Electrical and Electronic Equipment (WEEE). When the product is no longer required, it must be disposed of in an environmentally protective way. Contact your local solid waste authority for recycling information.



Environmental Protection

Recycle unwanted materials instead of disposing of them as waste. All tools, accessories and packaging should be sorted, taken to a recycling centre and disposed of in a manner which is compatible with the environment. When the product becomes completely unserviceable and requires disposal, drain off any fluids (if applicable) into approved containers and dispose of the product and the fluids according to local regulations.

NOTE: It is our policy to continually improve products and as such we reserve the right to alter data, specifications and component parts without prior notice.

IMPORTANT: No liability is accepted for incorrect use of this product.

WARRANTY: Guarantee is 12 months from purchase date, proof of which will be required for any claim.



Sole UK Distributor, Sealey Group.
Kempson Way, Suffolk Business Park,
Bury St. Edmunds, Suffolk.
IP32 7AR



01284 757500



01284 703534



www.sealey.co.uk



sales@sealey.co.uk