

Thank you for purchasing a Sealey product. Manufactured to a high standard this product will, if used according to these instructions and properly maintained, give you years of trouble free performance.

**⚠ IMPORTANT: PLEASE READ THESE INSTRUCTIONS CAREFULLY. NOTE THE SAFE OPERATIONAL REQUIREMENTS, WARNINGS AND CAUTIONS. USE THE PRODUCT CORRECTLY AND WITH CARE FOR THE PURPOSE FOR WHICH IT IS INTENDED. FAILURE TO DO SO MAY CAUSE DAMAGE AND/OR PERSONAL INJURY AND WILL INVALIDATE THE WARRANTY. PLEASE KEEP INSTRUCTIONS SAFE FOR FUTURE USE.**

## 1. SAFETY INSTRUCTIONS

### 1.1 ELECTRICAL SAFETY.

**⚠ WARNING! It is the user's responsibility to read, understand and comply with the following:**

You must check all electrical equipment and appliances to ensure they are safe before using. You must inspect power supply leads, plugs and all electrical connections for wear or damage. You must ensure the risk of electric shock is minimised by the installation of appropriate safety devices. An RCCB (Residual Current Circuit Breaker) should be incorporated in the main distribution board. We also recommend that a RCD (Residual Current Device) is used with all electrical products. It is particularly important to use an RCD with portable products that are plugged into an electrical supply not protected by an RCCB. If in doubt consult a qualified electrician. You may obtain a Residual Current Device by contacting your Sealey dealer. **You must** also read and understand the following instructions concerning electrical safety.

- 1.1.1 The **Electricity At Work Act 1989** requires all portable electrical appliances, if used on business premises, to be tested by a qualified electrician, using a Portable Appliance Tester (PAT), at least once a year.
- 1.1.2 The **Health & Safety at Work Act 1974** makes owners of electrical appliances responsible for the safe condition of those appliances and the safety of appliance operators. **If in any doubt about electrical safety, contact a qualified electrician.**
- 1.1.3 Ensure the insulation on all cables and the product itself is safe before connecting to the mains power supply. See 1.1.1. & 1.1.2. above and use a Portable Appliance Tester (PAT).
- 1.1.4 Ensure that cables are always protected against short circuit and overload.
- 1.1.5 Regularly inspect power supply leads and plugs for wear or damage and connections to ensure that none are loose.
- 1.1.6 **Important:** Ensure the voltage marked on the product is the same as the electrical power supply to be used, and check that plugs are fitted with the correct capacity fuse.
- 1.1.7 **DO NOT** pull or carry the powered appliance by its power supply lead.
- 1.1.8 **DO NOT** pull power plugs from sockets by the power cable.
- 1.1.9 **DO NOT** use worn or damage leads, plugs or connections. Immediately replace or have repaired by a qualified electrician.

1.1.10 A U.K. 3 pin plug with ASTA/BS approval is fitted. In case of damage, cut off and fit a new plug according to the following instructions (UK only - see diagram at right). Discard old plug safely.

**Ensure the unit is correctly earthed via a three-pin plug.**

- a) Connect the green/yellow earth wire to the earth terminal 'E'.
- b) Connect the brown live wire to the live terminal 'L'.
- c) Connect the blue neutral wire to the neutral terminal 'N'.
- d) Ensure the plug is fitted with a 13Amp fuse.
- e) After wiring, check that there are no bare wires, that all wires have been correctly connected, that the cable outer insulation extends past the cable restraint and that the cable restraint is tight.

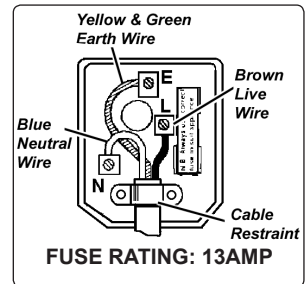

### 1.2 GENERAL SAFETY INSTRUCTIONS

- ✓ Familiarise yourself with the application and limitations of the compressor.
- ✓ Ensure that the compressor is in good order and condition before use. If in any doubt **DO NOT** use the unit and contact an electrician/service agent.
- ⚠ **IMPORTANT!** The compressor must be installed and commissioned by qualified personnel.
- ⚠ **WARNING! Compressor must only be serviced by an authorised agent. DO NOT tamper with, or attempt to adjust, pressure switch or safety valve.**
- ✓ Before moving or maintaining the compressor ensure it is unplugged from the mains supply and that the air tank pressure has been vented.
- ✓ Maintain the compressor in good condition and replace any damaged or worn parts. Use genuine parts only. *Unauthorised parts may be dangerous and will invalidate your warranty.*
- ✓ Read the instructions regarding any accessory used with the compressor. Ensure the safe working pressure of any air appliance used exceeds the compressor regulator. If using a spray gun, check the area selected for spraying is provided with an air change system or ventilation.
- ✓ Ensure the air supply valve is turned off before disconnecting the air supply hose.
- ✓ Use the compressor in a well ventilated area and ensure it is placed on a firm surface away from any heat sources.
- ✓ Keep tools and other items away from the compressor when it is in use and keep area clean and clear of unnecessary items.
- ✓ Ensure the air hose is not tangled, twisted or pinched.
- ✓ Keep children and unauthorised persons away from the working area.
- ✗ **DO NOT** dis-assemble compressor for any reason. The unit must be checked by qualified personnel only.
- ✗ **DO NOT** use the compressor outdoors, or in damp, or wet, locations and **DO NOT** operate within the vicinity of flammable liquids, gases or solids.
- ✗ **DO NOT** touch compressor cylinder, cylinder head or pipe from head to tank as these may be hot and will remain so for some time after shutdown.

- X **DO NOT** attempt to move the compressor by pulling the air tool hose.
- X **DO NOT** use this product to perform a task for which it has not been designed.
- X **DO NOT** operate the compressor with any of the panels removed.
- X **DO NOT** deface the certification plate attached to the end of the compressor tank.
- X **DO NOT** cover compressor or restrict air flow around the machine whilst operating.
- ▲ **DANGER! DO NOT direct the output jet of air towards people or animals.**
- X **DO NOT** operate the compressor without an inlet air filter.
- X **DO NOT** allow anyone to operate the compressor unless they have received full instructions and adequate training.
- **WARNING! The air tank is a pressure vessel and the following safety measures apply:**
- X **DO NOT tamper with the safety valve and DO NOT modify or alter the tank in any way, DO NOT strap anything to the tank.**
- X **DO NOT subject the tank to impact, vibration or to heat and DO NOT allow contact with abrasives or corrosives.**
- ✓ **Inspect inside walls for corrosion as per the maintenance section, have a detailed tank inspection carried out annually. Tank shell must not fall below the certified thickness at any point.**
- **WARNING! If an electrical fuse blows, ensure that it is replaced with one of identical type and rating.**
- ✓ **When the compressor is not in use, it should be switched off, isolated from the mains supply and the air drained from the tank.**
- ✓ When not in use, store the compressor carefully in a safe, dry, childproof location.
- **IMPORTANT WARNING** - Air contaminants taken into the compressor will affect optimum performance.  
**Example:** Body filler dust or paint over-spray will clog the pump intake filter and may cause internal damage to pump/motor components.  
Please note that any parts damaged by any type of contamination will not be covered by warranty.

## 2. SPECIFICATIONS

Model . . . . .	SAC89025VLN . . . . .	SAC82425VLN
Max Motor Output (hp/kW) . . . . .	2.5/1.8 . . . . .	2.5/1.8
Voltage . . . . .	230 . . . . .	230
Air Displacement cfm (l/min) . . . . .	10.3 (292) . . . . .	10.3 (292)
Max Free Air Delivery cfm (l/min) . . . . .	7.5 (212) . . . . .	7.5 (212)
Tank Capacity (ltr) . . . . .	90 . . . . .	24

Model . . . . .	SAC89025VLN . . . . .	SAC82425VLN
Maximum Pressure (psi/bar) . . . . .	145/10 . . . . .	145/10
Noise dB(a) . . . . .	66 . . . . .	57
Noise Lw(a) . . . . .	90 . . . . .	80
Weight kg . . . . .	83 . . . . .	96
Dimensions (WxDxH) mm . . . . .	1030x520x1020 . . . . .	490x700x930

All performance figures are ± 5%  
\* **Note:** 2.5 bar is recommended pressure setting for spraying.  
6.0 bar is recommended pressure setting for air tools.

## 3. ASSEMBLY AND INSTALLATION

- ### 3.1 ASSEMBLY
- 3.1.1 Remove compressor from packaging and inspect for any shortages or damage. If anything is found to be missing or damaged, contact your supplier.
  - 3.1.2 Save the packing material for future transportation of the compressor. We recommend that the packing is stored in a safe location, at least for the period of the guarantee. Then, if necessary, it will be easier to send the compressor to the service centre.
  - 3.1.3 Confirm that the mains voltage corresponds with the voltage shown on the compressor data plate.
  - 3.1.4 **SAC89025VLN ONLY** - Fit the main wheels (fig.1.A) and two smaller wheels (fig.1.B) to the main frame using the nuts, bolts and washers supplied.
- ### 3.2 INSTALLATION
- 3.2.1 The compressor should be installed on a flat, firm surface, or one that does not exceed 10° either transversely or longitudinally, and should be in a position that allows good air circulation around the unit.
  - 3.2.2 The compressor is shipped with oil in the pump, but the level needs checking before starting the unit for the first time. Check the oil level by referring to the oil dipstick (fig.2, fig.3) to check the oil. If the oil level is not between minimum and maximum on the dipstick it should be topped up. Remove the dipstick and if required, pour in the recommended oil. On Model SAC82425VLN one of the side panels will need to be removed to get to the motor (fig.3).
  - 3.2.3 The compressor must be positioned so that the panels may be removed and compressor components easily accessed for maintenance. The location must have good air exchange and an adequate air flow around the unit as the compressor generates significant heat. In contaminated areas an extraction system must be installed to remove dust, vapours and gases. **DO NOT** install the compressor in very high dust locations.

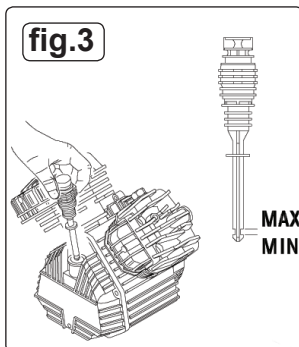
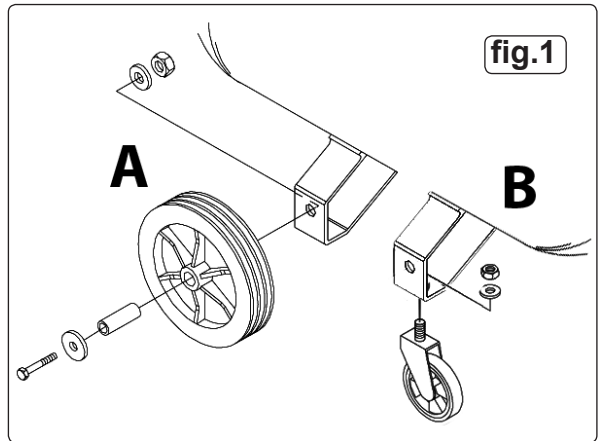

## 4. OPERATION

- ❑ **WARNING!** Ensure that you have read, understood and apply Section 1 safety instructions.

**IMPORTANT.** The use of extension leads to connect this compressor to the mains is not recommended as the resulting voltage drop reduces motor, and therefore pump, performance and could cause damage to your compressor.

- ❑ **IMPORTANT**

The motor on this compressor is 2.5HP/230V and at normal mains voltage will start within the capacity of a 13Amp fused circuit.

Certain local conditions relating to electrical supply in the UK can result in the voltage varying between a low of 216Volts and a high of 253Volts and at such times the 13 Amp fuse in the compressor plug may blow. This is normal and is not a fault with the compressor. However if it happens regularly we recommend that you consult an electrician with a view to installing a 16Amp supply, with contact breaker, to avoid the inconvenience of frequent fuse replacement. If using an extension lead ensure that cable size is at least 2.5mm<sup>2</sup>. Ensure cable is fully unwound.

- ❑ **IMPORTANT**

Take care when selecting tools for use with the compressor.

Air tool manufacturers normally express the volume of air required to operate a tool in cubic feet per minute (cfm). This refers to free air delivered by the compressor ('air out') which varies according to the pressure setting. Do not confuse this with the compressor displacement which is the air taken in by the compressor ('air in'). 'Air out' is always less than 'air in' and so it is important that, before choosing equipment, you study the 'Free Air Delivery' figures shown in Specifications, Section 2.

### 4.1 STARTING THE COMPRESSOR.

- 4.1.1 **SAC89025VLN** is fitted with a push/pull type of ON/OFF switch (fig.4A). To turn the compressor 'ON' pull the switch knob upwards. To turn the compressor 'OFF' push the switch knob downwards.

**SAC82425VLN** is fitted with a rocker type of ON/OFF switch (fig.5A). To turn the compressor 'ON' push the switch to 'I' to turn the compressor 'OFF' push the switch to 'O'.

- 4.1.2 Check that the ON/OFF switch is in the "OFF" position and the regulator tap (fig.4C & fig.5D) is closed (Zero '0' bar, Anti-clockwise).

- 4.1.3 Plug mains lead into mains supply and start the compressor by turning it on.

- 4.1.4 Start the compressor and leave the compressor running with the regulator tap (fig.4C & fig.5D) set to maximum pressure. Make sure that the pressure in the tank rises and that the compressor stops automatically when the maximum pressure value allowed - written on the specification plate and shown on the gauge (fig.4G & fig.5C) - is achieved. The compressor will now operate automatically. The pressure switch stops the motor when the maximum tank pressure is reached, and will restart it when pressure falls below the minimum threshold - approx. 2bar (29psi) less than the maximum pressure.

- 4.1.5 Stop the compressor by pushing the rocker switch to 'O' or pushing the switch downwards (fig.4A & fig.5A). The compressed air inside the compressor head will flow out, making the restart easier and preventing the motor from being damaged.

**DO NOT**, other than in an emergency, stop the compressor by switching off the mains socket, or by pulling the plug out of the socket, as the pressure relief will not then occur and motor damage may result upon restart.

When the compressor runs correctly and is stopped correctly there will be:

(a) a whistle of compressed air when the motor stops,

(b) a protracted whistle (about 20-25 seconds) when the compressor starts with no pressure in the tank.

- 4.1.6 The output pressure is regulated by the pressure regulator tap (fig.4C & fig.5D). Turn the tap clockwise to increase pressure and anti-clockwise to reduce it. The tap can be locked at any required setting by tightening the locking ring up against the underside of the tap. To determine the correct working pressure for any piece of equipment check the corresponding manual. When the compressor is not being used, set the regulated pressure to zero so as to avoid damaging the pressure reducer.

**NOTE:** a) If the motor does not cut in and out, but runs continuously when using an air appliance, the capacity of the compressor may be too small for the equipment or tool.

b) The gauges on the left (fig.4G & fig.5C) indicates the pressure inside the main tank. The gauges on the right (fig.4F & fig.5E) indicate the pressure supplied to the air equipment.

Should the pressure in the main tank exceed the pre-set switch maximum, the safety valve will activate.

- ❑ **WARNING!** For this reason **DO NOT** tamper with, or adjust, the pre-set switch or safety valve.

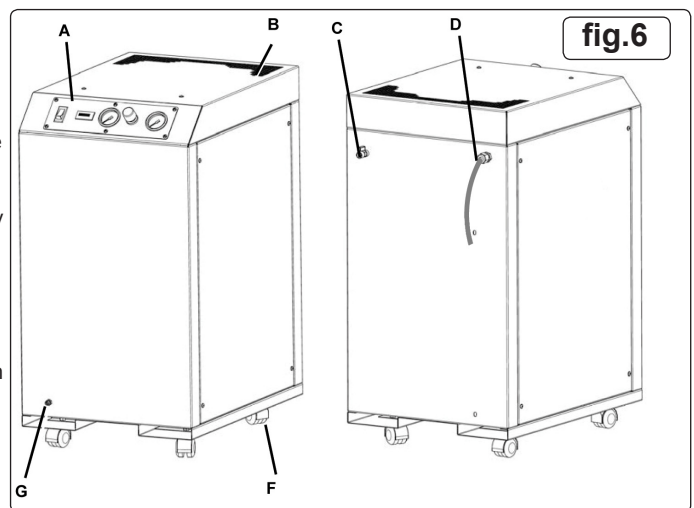
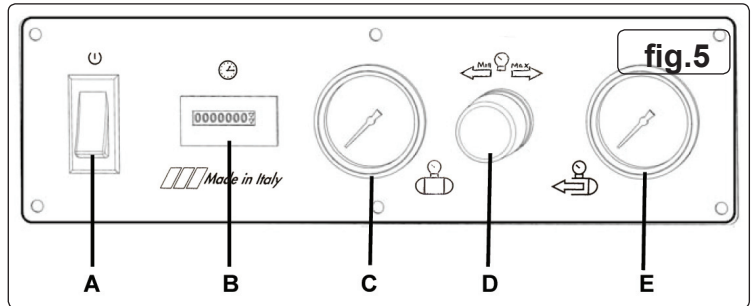
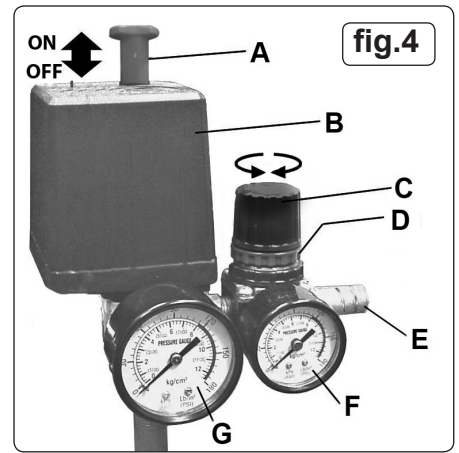

## 5. MAINTENANCE

In order to keep the compressor in good working condition, periodic maintenance is essential.

- ❑ **IMPORTANT! Failure to carry out maintenance tasks may invalidate the warranty on your compressor.**
- ❑ **WARNING! Before performing any maintenance operation, switch off compressor, disconnect from power supply and vent air from tank. Remove front and rear panels to provide access and light.**

### 5.1 OPERATIONS TO BE CARRIED OUT AFTER THE FIRST 5 WORKING HOURS:

- 5.1.1 Check that all nuts/bolts are tight, particularly those retaining the crankcase and cylinder heads.

### 5.2 Operations to be carried out after the first 100 working hours:

- 5.2.1 Replace the lubricating oil (see 5.9. below).

### 5.3 OPERATIONS TO BE CARRIED OUT DAILY:

- 5.3.1 Regularly clean dirt and dust away from the safety devices with a clean cloth or blowing with low pressure compressed air. Generally keep the compressor clean.

### 5.4 OPERATIONS TO BE CARRIED OUT WEEKLY:

- 5.4.1 Drain condensation by opening the valve located under the tank of SAC89024VLN (fig.7) or the bottom of the front panel on SAC82425VLN (fig.6G). Place a container under the valve to collect any condensation, as it may contain residual oil. Close valve after draining condensation and dispose of it safely.

### 5.5 OPERATIONS TO BE CARRIED OUT MONTHLY: SAC89025VLN

(or more frequently, if the compressor operates in a very dusty atmosphere)

- 5.5.1 Clean the air filters. Turn off the compressor and using stored air from it's tank, clean the filters with compressed air. The top cover of SAC89025VLN needs to be removed. Remove the air filter assembly by removing the single phillips screw.

- ❑ **IMPORTANT! Wear eye protection and DO NOT direct air towards the body or hands. DO NOT operate the compressor without the filters as foreign bodies or dust could seriously damage the pump. Replace the filter elements.**

### 5.6 OPERATIONS TO BE CARRIED OUT EVERY 50 HOURS: SAC82425VLN

(or more frequently, if the compressor operates in a very dusty atmosphere)

- 5.6.1 Clean the air filters. Turn off the compressor and using stored air from it's tank, clean the filters with compressed air. Both side panels of SAC89025VLN need to be removed. Remove the air filter assembly by removing the single phillips screw.

- ❑ **IMPORTANT! Wear eye protection and DO NOT direct air towards the body or hands. DO NOT operate the compressor without the filters as foreign bodies or dust could seriously damage the pump. Replace the filter elements.**

### 5.7 OPERATIONS TO BE CARRIED OUT EVERY 100 HOURS:

- 5.7.1 Check oil level, top up if necessary, one of the side panels on SAC89025VLN will need to be removed to check the oil level.

- 5.7.2 Check for oil leaks.

### 5.8 OPERATIONS TO BE CARRIED OUT EVERY 200 HOURS:

- 5.8.1 Check the automatic cut-out at maximum pressure, and the automatic cut-in at 2 bar below maximum pressure.

- 5.8.2 Replace air filters (See 5.5 / 5.6).

### 5.9 OPERATIONS TO BE CARRIED OUT EVERY 500 HOURS:

- 5.9.1 Replace the lubricating oil.

Remove the oil breather plug/dipstick then remove oil drain bolt (fig.8), draining oil into a suitable container. Drain when the compressor is hot if possible, so that the oil drains rapidly and completely.

**NOTE!** For SAC89025VLN its recommended to use a suction oil drainer, due to the design of the compressor, space around the drain plug is minimal. Incline compressor to ensure complete drainage. Replace oil drain bolt and refill with fresh oil through the oil filler/breather aperture (fig.8). **DO NOT** overfill. Replace oil breather plug/dipstick.

#### Recommended oils:

Synthetic oil suitable for temperatures ranging from -5°C to 45°C: viscosity 5W50. We do not recommend using mineral oil in these compressors.

Part No.	Qty.	Description
FSO1	1ltr x 12	Compressor oil fully synthetic
FSO1S	1ltr x 1	Compressor oil fully synthetic
FSO5	5ltr x 1	Compressor oil fully synthetic

- ❑ **WARNING! Dispose of waste oil only in accordance with local authority requirements.**

- 5.10. **IMPORTANT WARNING** - Air contaminants taken into the compressor will affect optimum performance. Example: Body filler dust or paint overspray will clog the pump intake filter and may cause internal damage to pump/motor components. Please note that any parts damaged by any type of contamination will not be covered by warranty.

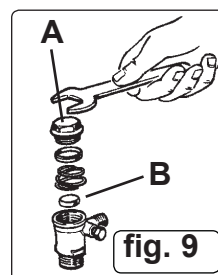
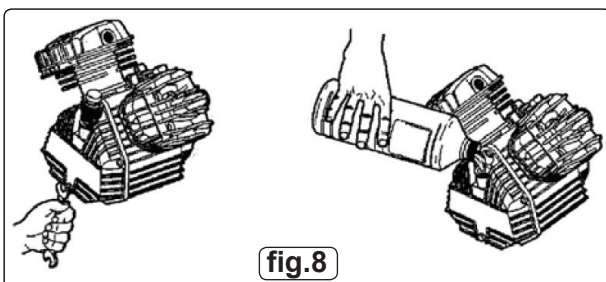
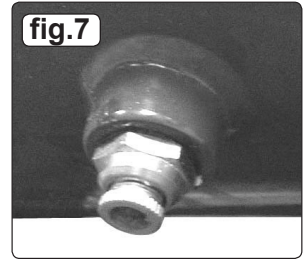

## 6. TROUBLE SHOOTING

Fault	Cause	Remedy
Pressure drop in the tank	Air leaks at connections	Run compressor to max. pressure, switch off. Brush soap solution over connections and look for bubbles. Tighten connections showing leaks. If problem persists contact Authorised Service Agent.
Pressure switch valve leaks when compressor is idle	Non-return valve seal defective	Empty the air tank, remove the non-return valve cap 'A' (fig.9) and clean. If necessary, replace the seal 'B'.
Compressor stops and does not restart	Overload cut-out operated - motor overheating	Wait for motor to cool and restart.
Compressor stops and does not restart	Motor failure	Contact Authorised Service Agent.
Compressor does not stop at max. pressure	Pressure switch fault	Contact Authorised Service Agent.
Compressor does not reach max. pressure	Filter clogged Head gasket or valve fault	Replace filter element. Contact Authorised Service Agent.
Compressor noisy with metallic knock	Bearing or piston damage	Contact Authorised Service Agent.

Parts support is available for this product. To obtain a parts listing and/or diagram, please log on to [www.sealey.co.uk](http://www.sealey.co.uk), email [sales@sealey.co.uk](mailto:sales@sealey.co.uk) or phone 01284 757500.

**NOTE:** It is our policy to continually improve products and as such we reserve the right to alter data, specifications and component parts without prior notice.

**IMPORTANT:** No liability is accepted for incorrect use of this product.

**WARRANTY:** Guarantee is 12 months from purchase date, proof of which will be required for any claim.

**INFORMATION:** For a copy of our latest catalogue and promotions call us on 01284 757525 and leave your full name and address, including postcode.



Sole UK Distributor, Sealey Group,  
Kempson Way, Suffolk Business Park,  
Bury St. Edmunds, Suffolk,  
IP32 7AR



01284 757500



[www.sealey.co.uk](http://www.sealey.co.uk)



01284 703534



[sales@sealey.co.uk](mailto:sales@sealey.co.uk)

