

Thank you for purchasing a Sealey product. Manufactured to a high standard this product will, if used according to these instructions and properly maintained, give you years of trouble free performance.



IMPORTANT: PLEASE READ THESE INSTRUCTIONS CAREFULLY. NOTE THE SAFE OPERATIONAL REQUIREMENTS, WARNINGS & CAUTIONS. USE THE PRODUCT CORRECTLY AND WITH CARE FOR THE PURPOSE FOR WHICH IT IS INTENDED. FAILURE TO DO SO MAY CAUSE DAMAGE OR PERSONAL INJURY AND WILL INVALIDATE THE WARRANTY. PLEASE KEEP INSTRUCTIONS SAFE FOR FUTURE USE.

1. SAFETY INSTRUCTIONS

1.1. ELECTRICAL SAFETY

WARNING! It is the responsibility of the owner and the operator to read, understand and comply with the following: You must check all electrical products, before use, to ensure that they are safe. You must inspect power cables, plugs, sockets and any other connectors for wear or damage. You must ensure that the risk of electric shock is minimised by the installation of appropriate safety devices. A Residual Current Circuit Breaker (RCCB) should be incorporated in the main distribution board. We also recommend that a Residual Current Device (RCD) is used. It is particularly important to use an RCD with portable products that are plugged into a supply which is not protected by an RCCB. If in any doubt consult a qualified electrician. You may obtain a Residual Current Device by contacting your Sealey dealer. You must also read and understand the following instructions concerning electrical safety.

- 1.1.1. The **Electricity at Work Act 1989** requires that all portable electrical appliances, if used on business premises, are tested by a qualified electrician, using a Portable Appliance Tester (PAT), at least once a year.
- 1.1.2. The **Health & Safety at Work Act 1974** makes owners of electrical appliances responsible for the safe condition of those appliances and the safety of the appliance operators. **If in any doubt about electrical safety, contact a qualified electrician.**
- 1.1.3. Ensure that the insulation on all cables and on the appliance is safe before connecting it to the power supply. See 1.1.1. and 1.1.2. and use a Portable Appliance Tester.
- 1.1.4. Ensure that cables are always protected against short circuit and overload.
- 1.1.5. Regularly inspect power supply cables and plugs for wear or damage and check all connections to ensure that none is loose.
- 1.1.6. **Important:** Ensure that the voltage marked on the appliance matches the power supply to be used and that the plug is fitted with the correct fuse - see fuse rating below.
- 1.1.7. **DO NOT** pull or carry the appliance by the power cable.
- 1.1.8. **DO NOT** pull the plug from the socket by the cable.
- 1.1.9. **DO NOT** use worn or damaged cables, plugs or connectors. Immediately have any faulty item repaired or replaced by a qualified electrician. When a BS 1363/A UK 3 pin plug is damaged, cut the cable just above the plug and dispose of the plug safely.

Fit a new plug according to the following instructions (UK only).
 a) Connect the **GREEN/YELLOW** earth wire to the earth terminal 'E'.

b) Connect the **BROWN** live wire to the live terminal 'L'.

c) Connect the **BLUE** neutral wire to the neutral terminal 'N'.

d) **After wiring, check that there are no bare wires, that all wires have been correctly connected, that the cable outer insulation extends beyond the cable restraint and that the restraint is tight.**

Double insulated products, which are always marked with this symbol , are fitted with live (brown) and neutral (blue) wires only. To rewire, connect the wires as indicated in diagram.

DO NOT connect either wire to the earth terminal.

- 1.1.10. Products which require more than 13 amps are supplied without a plug. In this case you must contact a qualified electrician to ensure that a suitably rated supply is available.

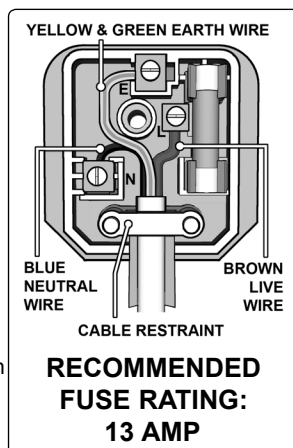

We recommend that you discuss the installation of an industrial round pin plug and socket with your electrician.

- IMPORTANT!** The use of extension leads to connect these compressors to the mains is not recommended as the resulting voltage drop reduces motor, and therefore pump performance.

1.2. GENERAL SAFETY

- ✓ Familiarise yourself with the application and limitations of the compressor.
- ✓ Ensure the compressor is in good order and condition before use. If in any doubt do not use the unit and contact an electrician/service agent.
- WARNING! Compressor must only be serviced by an authorised agent. DO NOT tamper with, or attempt to adjust, pressure switch or safety valve.**
- ✓ Before moving, or maintaining the compressor ensure it is unplugged from the mains supply and that the air tank pressure has been vented.
- ✓ Maintain the compressor in good condition and replace any damaged or worn parts. Use genuine parts only. *Unauthorised parts may be dangerous and will invalidate your warranty.*
- ✓ Read the instructions relating to any accessory to be used with this compressor. Ensure the safe working pressure of any air appliance used exceeds compressors output pressure. If using a spray a gun, check that the area selected for spraying is provided with an air change/ventilation system.
- ✓ Ensure the air supply valve is turned off before disconnecting the air supply hose.
- ✓ To move the compressor use the handle only. Maintain unit's centre of gravity when lifting. **DO NOT** attempt to lift or move the compressor by any other means.
- ✓ Use the compressor in a well ventilated area and ensure it is placed on a firm surface.
- ✓ Keep tools and other items away from the compressor when it is in use, and keep area clean and clear of unnecessary items.
- ✓ Ensure the air hose is not tangled, twisted or pinched.

- ✓ Keep children and unauthorised persons away from the working area.
- ✗ **DO NOT** dis-assemble compressor for any reason. The unit must be checked by qualified personnel only.
- ✗ **DO NOT** use the compressor outdoors, or in damp, or wet, locations.
- ✗ **DO NOT** operate within the vicinity of flammable liquids, gases or solids.
- ✗ **DO NOT** touch compressor cylinder, cylinder head or pipe from head to tank as these may be hot.
- ✗ **DO NOT** use this product to perform a task for which it has not been designed.
- ✗ **DO NOT** deface the certification plate attached to the compressor tank.
- ✗ **DO NOT** cover the compressor or restrict air flow around the unit whilst operating.
- ☐ **DANGER! DO NOT** direct the output jet of air towards people or animals.
- ✗ **DO NOT** operate the compressor without an air filter.
- ✗ **DO NOT** allow anyone to operate the compressor unless they have received full instructions.
- ☐ **WARNING!** The air tank is a pressure vessel and the following safety measures apply:
- ✗ **DO NOT** tamper with the safety valve, **DO NOT** modify or alter the tank in any way and **DO NOT** strap anything to the tank.
- ✗ **DO NOT** subject the tank to impact, vibration or to heat and **DO NOT** allow contact with abrasives or corrosives.
- ✓ Drain condensation from tank daily.
- ☐ **WARNING!** If an electrical fuse blows, ensure it is replaced with an identical fuse type and rating.
- ✓ When not in use, store the compressor carefully in a safe, dry, childproof location.

2. INTRODUCTION & SPECIFICATION

Aluminium cylinders with cast iron liners give reduced weight and improved resistance to wear. Suitable for general-purpose workshop applications. Pump head directly coupled to heavy-duty induction motor for reliable operation. Precision welded receiver tank manufactured to meet Pressure Vessel Directive 87/404/EEC. Fitted with fully automatic pressure cut-out switch, air regulator and tank and supply pressure gauges. Supplied with handle and wheels for easy manoeuvrability. Fitted with ASTA/BS approved non-rewirable plug.

MODEL	SAC5030VE
Motor output	3.0hp
Voltage/phase	230V - 1ph
Rated supply	13A
Noise level	97LwA
Air displacement	11.6cfm-328l/m
Maximum free air delivery	8.1cfm-230l/m
Tank capacity	50ltr
Max pressure	116psi / 8bar
Weight	37kg
Dimensions (W x D x H)	660 x 420 x 650mm

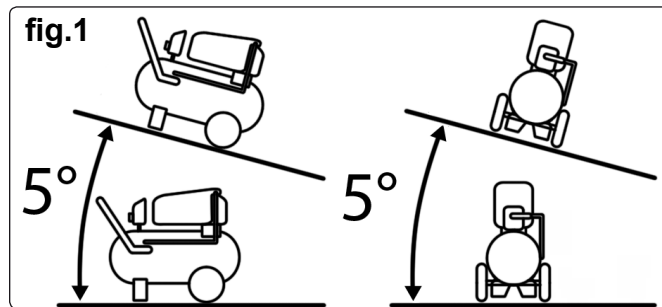
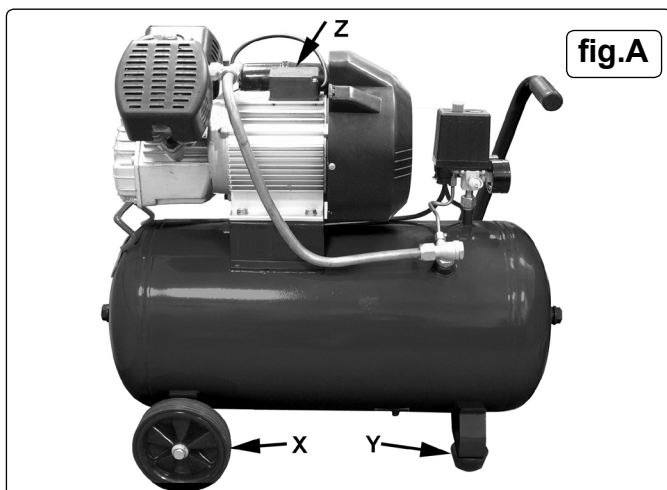

3. PREPARATION

- 3.1. Remove compressor from packaging and inspect for any shortages or damage. If anything is found to be missing or damaged contact your supplier.
- 3.2. Save the packing material for future transportation of the compressor. We recommend that you store the packing in a safe location, at least for the period of the guarantee. Then, if necessary, it will be easier to send the compressor to the service centre.
- 3.3. Confirm that the mains voltage corresponds with the voltage shown on the compressor data plate.
- 3.4. Assemble the wheels (fig.A.X) and rubber feet (fig.A.Y) to the main frame using the nuts, bolts and washers supplied.
- 3.5. The compressor should be operated on a flat surface, or one that does not exceed 10° either transversely or longitudinally (fig.1), and should be in a position that allows good air circulation around the unit.
- 3.6. Remove the plastic transit plug from the oil filler hole.
- 3.7. Before using the compressor check the oil level by referring to the oil sight glass (fig.2C). If the oil level is not up to the red centre mark it should be further topped up with recommended oil (See section 5.7). Screw the filler/breather cap into the aperture as shown in fig.2B.
- 3.8. Screw the back half of a filter unit into the downward facing port openings in each head as shown in fig.2.A. Place a filter cover over each threaded rod protruding from the back half of the filter and secure each with a wing nut. Refer also to fig.4.

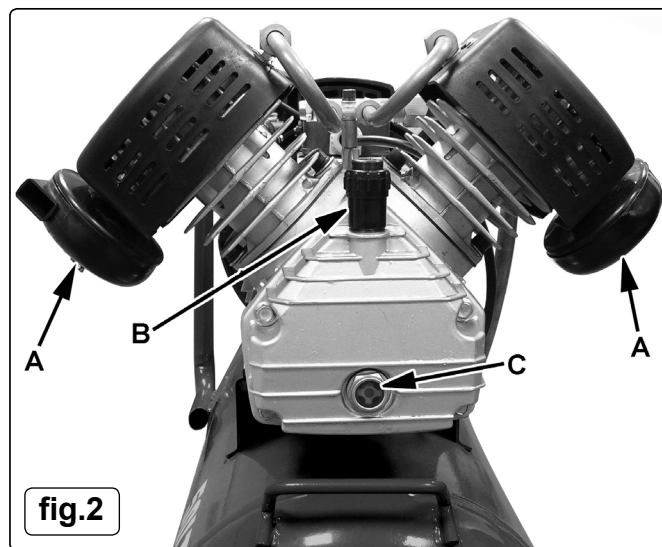

4. OPERATION

- ☐ **WARNING!** Ensure that you have read, understood and apply Section 1 safety instructions.
- 4.1. **IMPORTANT.** The use of extension leads to connect this compressor to the mains is not recommended as the resulting voltage drop reduces motor, and therefore pump, performance and could damage your compressor.
- 4.2. Take care when selecting tools for use with the compressor. Air tool manufacturers normally express the volume of air required to operate a tool in cubic feet per minute (cfm).

This refers to free air delivered by the compressor ('air out') which varies according to the pressure setting. Do not confuse this with the compressor displacement which is the air taken in by the compressor ('air in'). 'Air out' is always less than 'air in' - due to losses within the compressor.

4.3. STARTING THE COMPRESSOR.

- 4.3.1. Your compressor is fitted with a push/pull type of ON/OFF switch. To turn the compressor 'ON' pull the switch knob upwards. To turn the compressor 'OFF' push the knob downwards. (See fig.3.1)
- 4.3.2. Check that the ON/OFF switch is in the "OFF" position, the regulator tap (fig.3.2) is closed (Zero '0' bar), and air tap (fig.3.4) is OFF.
- 4.3.3. Plug mains lead into mains supply and start the compressor by pulling the switch knob upwards.
- 4.3.4. When starting the compressor for the first time, leave it running for several minutes with the air tap (fig.3.4) open to ensure good distribution of the lubricating oil. Turn the compressor off and close the air tap. Restart the compressor and leave it running with air tap (fig.3.4) closed and regulator (fig.3.2) set to maximum pressure. Make sure that pressure in the tank rises and that the compressor stops automatically when the max. pressure value allowed - written on the specification plate and shown on the gauge (fig.3.6) - is achieved. The compressor will now operate automatically. The pressure switch (fig.3.8) stops the motor when the maximum tank pressure is reached and restarts it when pressure falls below the minimum threshold - approx. 2 bar (29psi) less than the maximum pressure.
- 4.3.5. Stop the compressor by pushing the switch knob (See fig.3.1) downwards. The compressed air inside the compressor head will flow out, making the restart easier and preventing the motor from being damaged. DO NOT, other than in an emergency, stop the compressor by switching off the mains power, or by pulling the plug out, as the pressure relief will not then occur and motor damage may result upon restart. When the compressor runs correctly and is stopped correctly there will be:
- (a) a whistle of compressed air when the motor stops,
 - (b) a protracted whistle (about 20-25 seconds) when the compressor starts with no pressure in the tank.
- 4.3.6. The output pressure is regulated by the pressure regulator (fig.3.2). Turn the knob clockwise to increase pressure and clockwise to reduce it. The knob can be locked at any required setting by tightening the locking ring (fig.3.3) up against the underside of the knob. To determine the correct working pressure for any piece of equipment check the corresponding manual. When the compressor is not being used set the regulated pressure to zero so as to avoid damaging the pressure reducer.
- NOTE: a) If the motor does not cut in and out, but runs continuously when using an air appliance, the capacity of the compressor may be too small for the equipment or tool.
b) The larger gauge (fig.3.6) indicates the pressure inside the main tank. The smaller gauge (fig.3.5) indicates the pressure supplied to the air equipment. Should the pressure in the main tank exceed the pre-set switch (fig.3.8) maximum, the safety valve (fig.3.7) will activate.
- WARNING! For this reason DO NOT tamper with, or adjust, the switch or safety valve.**
- 4.3.7. The compressor is fitted with a reset trip, located in the connection box on top of the motor (see fig.A.Z) The reset button is on the side of the box (fig.7). Should the trip activate, leave for 1 minute before pressing the button to reset. For possible causes of trip activation and remedies see section 6 Troubleshooting.

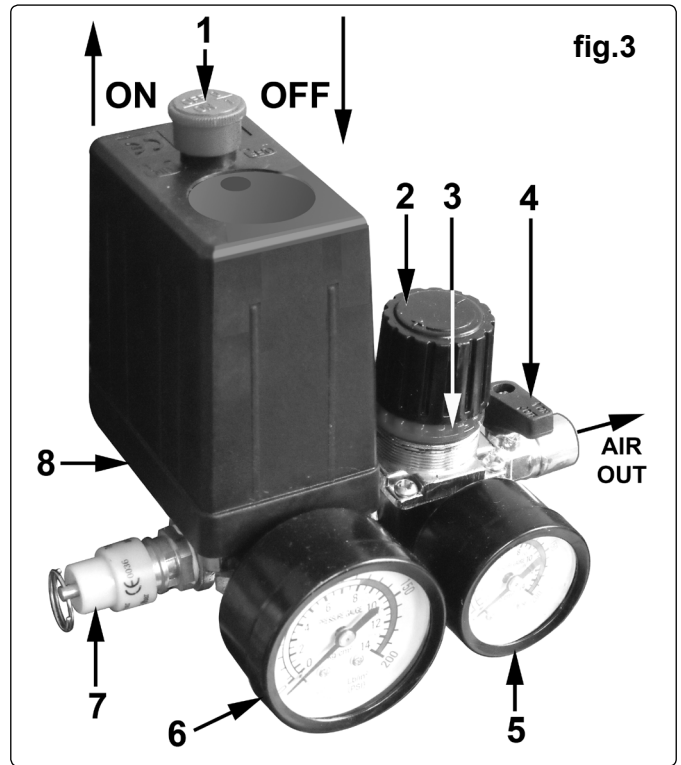

5.1. OPERATIONS TO BE CARRIED OUT AFTER THE FIRST 5 WORKING HOURS:

- a) Check that all bolts/nuts are tight, particularly those retaining the crank case and cylinder head.

5.2. OPERATIONS TO BE CARRIED OUT AFTER THE FIRST 50 WORKING HOURS:

- b) Replace the lubricating oil - see para 5.5.

5.3. OPERATIONS TO BE CARRIED OUT DAILY:

- a) Drain condensation by opening the valve located under the tank (fig.5). Place a container under the valve and slowly open the valve by turning anti-clockwise.

5.4. OPERATIONS TO BE CARRIED OUT EVERY 100 HOURS (or more frequently, if the compressor operates in a very dusty atmosphere)

- a) Check oil level and, if necessary, top up.
- b) Remove the filter elements (See fig.4) and clean with compressed air. (Wear eye protection). Do not operate the compressor without the filters as foreign bodies or dust could seriously damage the pump.
- c) Check for oil leaks

5.5. OPERATIONS TO BE CARRIED OUT EVERY 200 HOURS:

- a) Replace the lubricating oil. For oil specifications see 5.7. Remove the oil filler/breather plug (see fig.2.B) then unscrew oil sight glass (see fig.2.C) and drain the oil into a container. Drain when the compressor is hot so that oil drains rapidly and completely. Incline compressor to ensure complete drainage.

Replace oil sight glass and refill through the oil filler/breather aperture. Do not overfill. Replace filler/breather plug.

- b) Check the automatic cut-out at max. pressure and the automatic cut-in at 2 bar below.

- WARNING! Never mix different oils and do not use non-detergent/low quality oils as the compressor may be damaged.**

- WARNING! Dispose of waste oil only in accordance with local authority requirements.**

5. MAINTENANCE

In order to keep the compressor in good working condition, periodic maintenance is essential.

- WARNING! Before performing any maintenance operation, switch off the compressor, disconnect from electricity supply and release all air from the tank. IMPORTANT! Failure to carry out maintenance tasks may invalidate the warranty on your compressor.**

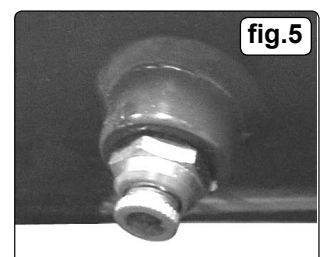
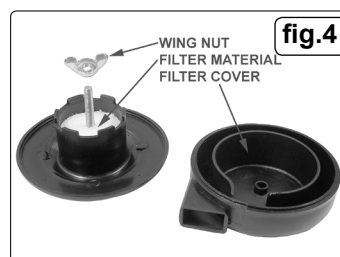

5.6. OPERATIONS TO BE CARRIED OUT EVERY 500 HOURS:

- a) Replace air filter. (See fig.4)
- b) Check all tube fittings and electrical connections.

5.7. Recommended oils;

Recommended oil for compressors, suitable for room temperatures ranging from +5°C to +25°C. SEALEY CPO or equivalent SAE 40 compressor oil. Room temperature below +5°C: SAE 20 compressor oil. Approximate oil capacity: 0.16 litres.

5.8. IMPORTANT WARNING - Air contaminants taken into the compressor will affect optimum performance. Example: Body filler dust or paint overspray will clog the pump intake filter and may cause internal damage to pump/motor components. Please note that any parts damaged by any type of contamination will not be covered by warranty.

5.9. Inspection of pressure tank both inside and out.

Under the PRESSURE SYSTEMS SAFETY REGULATIONS 2000 it is the responsibility of the owner of the compressor to initiate a system of inspection that both defines the frequency of the inspection and appoints a person who has specific responsibility for carrying out the inspection.

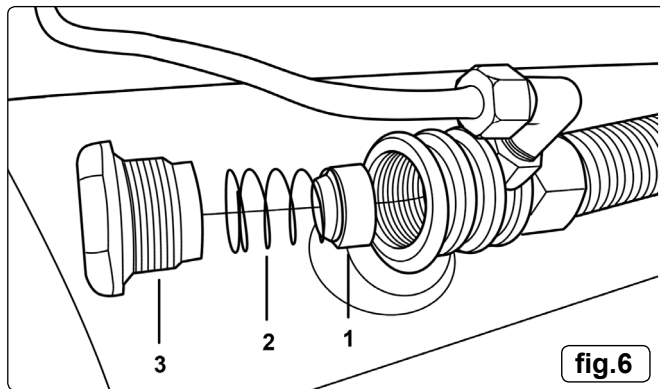

fig.6

6. TROUBLESHOOTING

FAULT	CAUSE	REMEDY
1A) Pressure drop in the tank	Air leaks at connections	Run compressor to max. pressure, switch off. Brush soap solution over connections and look for bubbles. Tighten connections showing leaks. If problem persists contact Authorised Service Agent
1B) Pressure drop in the tank	Air leaks from safety valve	Operate the safety valve manually by pulling on the ring. If valve continues to leak when in the closed position it should be replaced
1C) Pressure drop in the tank	Air leaks from cylinder head gasket	Check tightness of head bolts. If leak continues contact authorised Service Agent
2) Pressure switch valve leaks when compressor is idle	Non-return valve seal defective	Empty the air tank. Referring to fig.6, remove the non-return valve cap (3), spring (2) and seal (1). Clean the seal and its seat, or if necessary replace the seal
3) Air leaks from tank body or tank welds	Internal corrosion caused by infrequent tank draining or non permitted modifications to tank	Tank could rupture or explode. Cannot be repaired DISCONTINUE USE IMMEDIATELY
4A) Motor stops and will not restart	Thermal cut out has operated	Allow unit to cool for 30 minutes before restarting
4B) Motor stops and will not restart	Supply fuse has tripped	Press trip reset button (fig.7) and restart unit. If repeated tripping occurs replace the check valve or contact authorised Service Agent
5) Compressor stops and does not restart	Motor failure	Contact Authorised Service Agent
6A) Compressor does not stop at max. pressure	Pressure switch fault	Contact Authorised Service Agent
6B) Compressor does not stop at max. pressure	Filter clogged Head gasket or valve fault	Replace filter element. Contact Authorised Service Agent
7) Compressor noisy with metallic knock	Bearing or piston damage	Contact Authorised Service Agent
8) Excessive moisture in discharged air	High humidity environment	Drain tank after each use

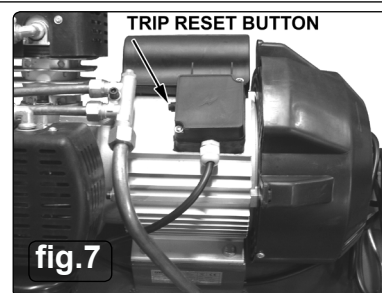
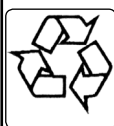

fig.7



Environmental Protection.

Recycle unwanted materials instead of disposing of them as waste. All tools, accessories and packaging should be sorted, taken to a recycle centre and disposed of in a manner which is compatible with the environment.



WEEE Regulations.

Dispose of this product at the end of its working life in compliance with the EU Directive on Waste Electrical and Electronic Equipment. When the product is no longer required, it must be disposed of in an environmentally protective way. Contact your local solid waste authority for recycling information.

NOTE: It is our policy to continually improve products and as such we reserve the right to alter data, specifications and component parts without prior notice.

IMPORTANT: No liability is accepted for incorrect use of this product.

WARRANTY: Guarantee is 12 months from purchase date, proof of which will be required for any claim.

INFORMATION: For a copy of our latest catalogue and promotions call us on 01284 757525 and leave your full name and address, including postcode.



Sole UK Distributor, Sealey Group,
Kempson Way, Suffolk Business Park,
Bury St. Edmunds, Suffolk,
IP32 7AR



01284 757500



www.sealey.co.uk



01284 703534



sales@sealey.co.uk