



DIRECT DRIVE AIR COMPRESSOR

MODEL NO: **SAC5030VA** **SAC10030VA**

Thank you for purchasing a Sealey product. Manufactured to a high standard, this product will, if used according to these instructions, and properly maintained, give you years of trouble free performance.

IMPORTANT: PLEASE READ THESE INSTRUCTIONS CAREFULLY. NOTE THE SAFE OPERATIONAL REQUIREMENTS, WARNINGS & CAUTIONS. USE THE PRODUCT CORRECTLY AND WITH CARE FOR THE PURPOSE FOR WHICH IT IS INTENDED. FAILURE TO DO SO MAY CAUSE DAMAGE AND/OR PERSONAL INJURY AND WILL INVALIDATE THE WARRANTY. KEEP THESE INSTRUCTIONS SAFE FOR FUTURE USE.



Refer to instructions



Wear eye protection



Wear ear protection



Ensure oil level is correct before first use



WARNING: High Voltage



WARNING: Hot surface



WARNING: Automatic start up



Indoor use only



DO NOT open the air cock before an air hose is attached

1. SAFETY

1.1. ELECTRICAL SAFETY

- **WARNING!** It is the responsibility of the owner and the operator to read, understand and comply with the following: You must check all electrical products before use to ensure that they are safe. You must inspect power cables, plugs, sockets and any other connectors for wear or damage. You must ensure that the risk of electric shock is minimised by the installation of appropriate safety devices. A Residual Current Circuit Breaker (RCCB) should be incorporated in the main distribution board. We also recommend that a Residual Current Device (RCD) is used. It is particularly important to use an RCD with portable products that are plugged into a supply which is not protected by an RCCB. If in any doubt consult a qualified electrician. You must also read and understand the following instructions concerning electrical safety:
 - 1.1.1. **The Health & Safety at Work Act 1974** makes owners of electrical appliances responsible for the safe condition of those appliances and the safety of the appliance operators. **If in any doubt about electrical safety, contact a qualified electrician.**
 - 1.1.2. Ensure that the insulation on all cables and on the appliance is safe before connecting it to the power supply.
 - 1.1.3. Ensure that cables are always protected against short circuit and overload.
 - 1.1.4. Regularly inspect power supply cables and plugs for wear or damage and check all connections to ensure that none are loose.
 - 1.1.5. **Important:** Ensure that the voltage marked on the appliance matches the power supply to be used and that the plug is fitted with the correct fuse.
 - × **DO NOT** pull or carry the appliance by the power cable.
 - × **DO NOT** pull the plug from the socket by the cable.
 - × **DO NOT** use worn or damaged cables, plugs or connectors. Immediately have any faulty item repaired or replaced by a qualified electrician.
 - 1.1.6. **Over/current Protection:** The user has to make provision for the installation of the over-current protection of the power circuit.
 - 1.1.7. **Electrical disconnecting device:** The user has to make provisions for the installation of the electrical disconnecting device of the power circuit. **NOTE:** If using a transformer to supply the compressor, it must be rated at a minimum of 2kVA to allow the compressor to run efficiently.

1.2. GENERAL SAFETY

- ✓ Before you connect the equipment to the mains supply make sure that the data on the rating plate are identical to the mains data .
- ✓ Familiarise yourself with the application and limitations of the compressor.
- ✓ Ensure the compressor is in good order and condition before use. If in any doubt **DO NOT** use the unit and contact your Sealey Stockist.
- ✓ Operation must be with all guards, covers, lids and enclosures correctly in place.
- ✓ Fully assemble the compressor before using for the first time.
- ✓ The concentration of processed gases that can displace breathing air shall be kept within acceptable levels. Reference EN 12021 for acceptable levels of contaminants in breathing air.
- ✓ Remove from mains supply when performing maintenance or inspections.
- **WARNING!** Item must be serviced by an authorised agent. **DO NOT** tamper with or attempt to adjust pressure switch or safety valve.
- × **DO NOT** carry out any welding operations on any pressurised part of the vessel.
- ✓ Before moving, or maintaining the compressor ensure it is unplugged from the mains supply and that the air tank pressure has been vented.
- ✓ Maintain the compressor in good condition and replace any damaged or worn parts. Use genuine parts only. Unauthorised parts may be dangerous and will invalidate your warranty.
- ✓ Delivery hoses should be fitted with a safety cord.
- ✓ It is essential to use separators, water traps and drains which process the liquids produced by the compressor system is put into operation.
- ✓ The compressor may only be used in suitable rooms (with good ventilation and an ambient temperature from +5°C to +40°C). Ensure there is no dust, acids, vapours, explosive gases, or inflammable gases in the room. The air intake should be from a clean, outside air source.
- ✓ Read the instructions relating to any accessory to be used with this compressor. Ensure the safe working pressure of any air appliance used exceeds compressors output pressure.
- ✓ Ensure the safe working pressure of any air appliance used exceeds compressors output pressure. If using a spray gun, check that the area selected for spraying is provided with an air change system/ventilation.
- ✓ Ensure the air supply valve is turned off before disconnecting the air supply hose to move a transportable compressor use the handle only. Lift the compressor so that the front leg gives enough clearance for manoeuvring but maintain unit's centre of gravity in front of the wheels. **DO NOT** attempt to lift or move the compressor by any other means.
- ✓ Use the compressor in a well ventilated area and ensure it is placed on a firm surface.

- ✓ Keep tools and other items away from the compressor when it is in use, and keep area clean and clear of unnecessary items.
- ✓ Ensure the air hose is not tangled, twisted or pinched.
- ✓ Keep children and unauthorised persons away from the working area.
- ✓ Only move the compressor by the handle (if portable).
- ✗ **DO NOT** dis-assemble compressor for any reason. The unit must be checked by qualified personnel only.
- ✗ **DO NOT** use the compressor outdoors, or in damp, or wet, locations.
- ✗ **DO NOT** operate within the vicinity of flammable liquids, gases or solids.
- ✗ **DO NOT** touch compressor cylinder, cylinder head or pipe from head to tank as these may be hot.
- ✗ **DO NOT** use this product to perform a task for which it has not been designed.
- ✗ **DO NOT** deface the certification plate attached to the compressor tank.
- ✗ **DO NOT** cover the compressor or restrict air flow around the unit whilst operating.
- ▲ **DANGER! DO NOT** direct the output jet of air towards people or animals.
- ✗ **DO NOT** operate the compressor without an air filter.
- ✗ **DO NOT** allow anyone to operate the compressor unless they have received full instructions.
- **WARNING!** The air tank is a pressure vessel and the following safety measures apply:
 - ✗ **DO NOT** tamper with the safety valve, **DO NOT** modify or alter the tank in any way and **DO NOT** strap anything to the tank.
 - ✗ **DO NOT** subject the tank to impact, vibration or to heat and **DO NOT** allow contact with abrasives or corrosives.
 - ✓ Drain condensation from tank daily and inspect inside walls for corrosion every three months and have a detailed tank inspection carried out annually. The tank shell must not fall below the certified thickness at any point.
- **WARNING!** If an electrical fuse blows, ensure it is replaced with an identical fuse type and rating.
 - ✓ When not in use, store the compressor carefully in a safe, dry, childproof location.
 - ✓ When the compressor is not in use, it should be switched off, disconnected from the mains supply and the air drained from the tank.
 - ✓ Under the PRESSURE SYSTEMS SAFETY REGULATIONS 2000 it is the responsibility of the owner of the compressor to initiate a system of inspection that both defines the frequency of the inspection and appoints a person who has specific responsibility for carrying out the inspection.

2. INTRODUCTION

V-Twin pump aluminium cylinder head with cast iron cylinder gives added resistance to wear. Pump head directly coupled to heavy-duty induction motor for reliable and quiet operation. Precision welded receiver tank manufactured to meet Pressure Vessel Directive. Suitable for general-purpose workshop applications. Fitted with fully automatic pressure cut-out switch and twin gauges displaying tank and working pressures. Fitted with 3-pin plug.

3. SPECIFICATION

Model No:	SAC5030VA	SAC10030VA
Air Displacement cfm(L/min):	12.4cfm(350L/min)	12.4cfm(350L/min)
Maximum Free Air Delivery cfm(L/min):	7cfm(198L/min)	7cfm(198L/min)
Maximum Pressure:	116psi(8bar)	116psi(8bar)
Minimum Rated Supply:	13A	13A
Motor Output:	3hp	3hp
Nett Weight:	38.8kg	48kg
Noise level:	97dB	97dB
Oil Capacity:	350ml	350ml
Outlet:	Quick Release Coupling	Quick Release Coupling
Phase:	1ph	1ph
Plug Type:	3-pin BS	3-pin BS
Power Cable length:	1.8m	1.8m
Reciver Capacity:	50L	100L
Size (W x D x H):	705mm x 335mm x 610mm	1040mm x 350mm x 720mm
Supply:	230V/13A	230V/13A

Additional Specification:

Short circuit current rating for each incoming power supply: 25A
 Type of distribution system in the system: Lower voltage
 Full load current for each incoming supply: 9A
 Intended media: Air
 Inlet intermediate pressure and temperatures: N/A
 Inlet discharge pressure and temperatures: Pressure 0.8MPA
 Temperature 70°C
 Maximum pressure ratio: 0.8MPA
 Pressure limits of the lubrication system: 0.8MPA
 Temperature limits of the lubrication system: 100°C
 Maximum speed of the unit: 2880RPM
 Minimum speed of the unit: 2880RPM

4. PREPARATION

- 4.1. Remove compressor from packaging and inspect for any shortages or damage. If anything is found to be missing or damaged contact your supplier.
- 4.2. Save the packing material for future transportation of the compressor. We recommend that you store the packing in a safe location, at least for the period of the guarantee. Then, if necessary, it will be easier to send the compressor to the service centre.
- 4.3. Confirm that the mains voltage corresponds with the voltage shown on the compressor data plate.
- 4.4. Assemble the wheels (fig.A.) to the main frame using the nuts, bolts and washers supplied.
- 4.5. Attach handle with bolts provided.
- 4.6. The compressor should be operated on a flat surface, or one that does not exceed 10° either transversely or longitudinally (fig.1), and should be in a position that allows good air circulation around the unit.
- 4.7. Before using the compressor check the oil level by referring to the oil sight glass (fig.2C). If the oil level is not up to the red centre mark it should be further topped up with recommended oil. Screw the filler/breather cap into the aperture as shown in fig.2B.

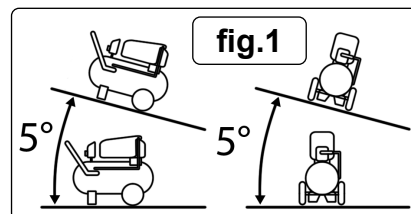

- 4.8. Screw the back half of a filter unit into the downward facing port openings in each head as shown in fig.2A. Place a filter cover over each threaded rod protruding from the back half of the filter and secure each with a wing nut. Refer also to fig.5.

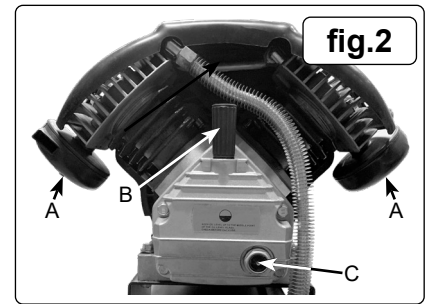

5. OPERATION

- ❑ **WARNING! ENSURE THAT YOU HAVE READ, UNDERSTOOD AND APPLY SECTION 1 SAFETY INSTRUCTIONS.**
- 5.1. **IMPORTANT.** The use of extension leads to connect this compressor to the mains is not recommended as the resulting voltage drop reduces motor, and therefore pump, performance and could damage your compressor.
- 5.2. **TAKE CARE WHEN SELECTING TOOLS FOR USE WITH THE COMPRESSOR.** Air tool manufacturers normally express the volume of air required to operate a tool in cubic feet per minute (cfm). This refers to free air delivered by the compressor ('air out') which varies according to the pressure setting. **DO NOT** confuse this with the compressor displacement which is the air taken in by the compressor ('air in'). 'Air out' is always less than 'air in' - due to losses within the compressor.
- 5.3. **STARTING THE COMPRESSOR.**
 - 5.3.1. Your compressor is fitted with a push/pull type of ON/OFF switch. To turn the compressor 'ON' pull the switch knob upwards. To turn the compressor 'OFF' push the knob downwards. (See fig.3.1).
 - 5.3.2. Check that the ON/OFF switch is in the "OFF" position, the regulator tap (fig.3.2) is closed (Zero '0' bar).
 - 5.3.3. Plug mains lead into mains supply and start the compressor by pulling the switch knob upwards.
 - 5.3.4. When starting the compressor for the first time, leave it running for several minutes with the air tap (fig.3b.8) open to ensure good distribution of the lubricating oil. Turn the compressor off and close the air tap. Restart the compressor and leave it running with air tap (fig.3b.8) closed and regulator (fig.3.2) set to maximum pressure. Make sure that pressure in the tank rises and that the compressor stops automatically when the max. pressure value allowed - written on the specification plate and shown on the gauge (fig.3.6) - is achieved. The compressor will now operate automatically. The pressure switch stops the motor when the maximum tank pressure is reached and restarts it when pressure falls below the minimum threshold - approx. 2 bar (29psi) less than the maximum pressure.
 - 5.3.5. Stop the compressor by pushing the switch knob (See fig.3.1) downwards. The compressed air inside the compressor head will flow out, making the restart easier and preventing the motor from being damaged. **DO NOT**, other than in an emergency, stop the compressor by switching off the mains power, or by pulling the plug out, as the pressure relief will not then occur and motor damage may result upon restart. When the compressor runs correctly and is stopped correctly there will be:
 - (a) a whistle of compressed air when the motor stops.
 - (b) a protracted whistle (about 20-25 seconds) when the compressor starts with no pressure in the tank.
 - 5.3.6. The output pressure is regulated by the pressure regulator (fig.3.2). Turn the knob anti clockwise to increase pressure and clockwise to reduce. The knob can be locked at any required setting by tightening the locking ring (fig.3.3) up against the underside of the knob. To determine the correct working pressure for any piece of equipment check the corresponding manual. When the compressor is not being used set the regulated pressure to zero so as to avoid damaging the pressure reducer.

NOTE: a) If the motor does not cut in and out, but runs continuously when using an air appliance, the capacity of the compressor may be too small for the equipment or tool.

b) The larger gauge (fig.3.6) indicates the pressure inside the main tank. The smaller gauge (fig.3.5) indicates the pressure supplied to the air equipment. Should the pressure in the main tank exceed the pre-set switch maximum, the safety valve (fig.3b.7) will activate.
- ❑ **WARNING! For this reason DO NOT tamper with, or adjust, the switch or safety valve.**
- 5.3.7. The compressor is fitted with a reset trip, located at the side of the air cylinder (see fig.4.9) should the trip activate, leave for 1 minute before pressing the button to reset. For possible causes of trip activation and remedies see section 6 Troubleshooting.

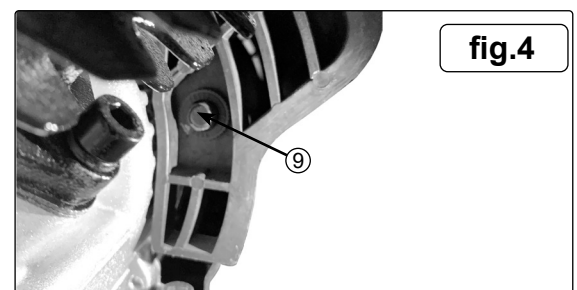
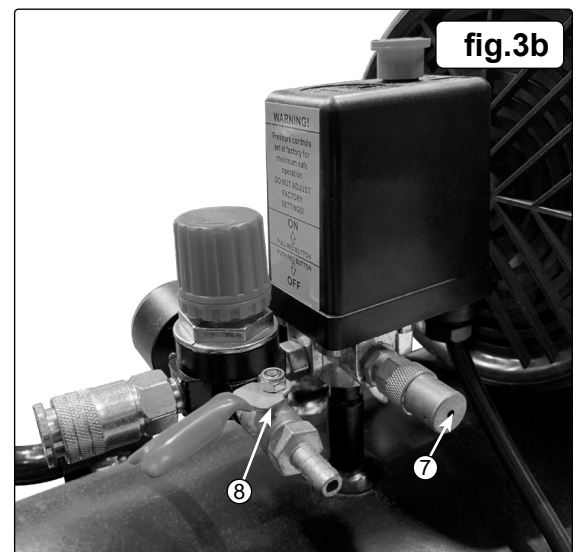
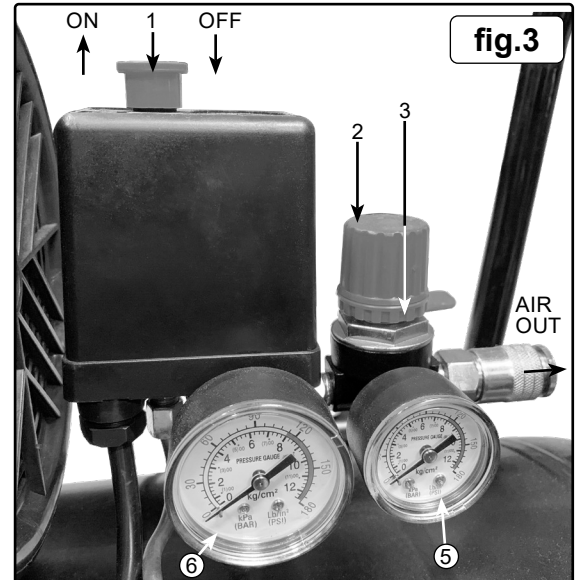

6. MAINTENANCE

- ❑ **WARNING! Before performing any maintenance operation, switch off the compressor, disconnect from electricity supply and release all air from the tank. In order to keep the compressor in good working condition, periodical maintenance is essential.**
- 6.1. **After the first 100 working hours replace the lubricating oil - see Item 6.4.1.**

6.2. OPERATIONS TO BE CARRIED OUT DAILY:

- 6.2.1. Drain condensation, place a container under the valve and open the valve by turning anti-clockwise (fig.6). Re-tighten the valve.
- 6.2.2. Check that all nuts and bolts are tight, particularly those retaining the crankcase and cylinder heads.

6.3. OPERATIONS TO BE CARRIED OUT EVERY 100 HOURS: (or more frequently, if the compressor operates in a very dusty atmosphere).

- 6.3.1. Check oil level and, if necessary, top it up.
- 6.3.2. Remove the air filter element by unscrewing the air filter holder (fig.5) and prising open the holder. Clean air filter by blowing through with an air line at low pressure, from the clean side. Alternatively, wash air filter in soapy water, rinse and dry. **DO NOT** operate the compressor without the air filters, as foreign bodies or dust could seriously damage the pump.

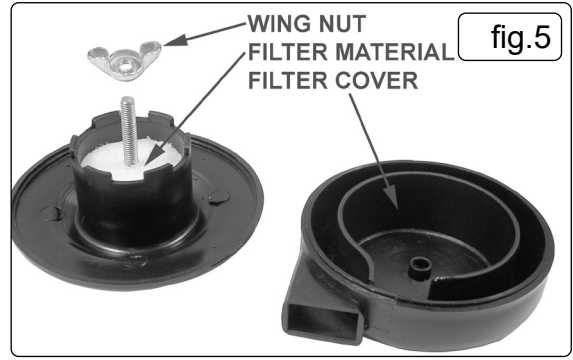

- 6.3.3. Check for oil leaks.

6.4. OPERATIONS TO BE CARRIED OUT EVERY 500 HOURS:

- 6.4.1. Replace the lubricating oil. Remove the oil filler/breather (fig.2B) and unscrew the drain bolt (fig.2C), drain the oil into a suitable container. Drain when the compressor is hot so that the oil drains rapidly and completely. Incline the compressor to ensure complete drainage. Replace the drain bolt and refill with fresh oil through the filler aperture. **DO NOT** overfill.
- 6.4.2. Replace oil filler/breather (fig.2B).



6.5. RECOMMENDED OIL:

- 6.5.1. Suitable for room temperatures ranging from +5°C to +25°C: SEALEY CPO or equivalent SAE 40 compressor oil.
- 6.5.2. Room temperature below +5°C: SAE 20 compressor oil.
- 6.5.3. **WARNING!** Never mix different oils and **DO NOT** use non-detergent/low quality oils as the compressor may be damaged.
- 6.5.4. Check the automatic cut-out at maximum pressure and the automatic cut-in at 2 bar below that.
- 6.5.5. Replace air filter (fig.5).
- 6.5.6. Check all tube fittings and electrical connections.

IMPORTANT! Failure to carry out maintenance tasks may invalidate the warranty on your compressor.

- WARNING - Air contaminants** taken into the compressor will affect optimum performance. Example: Body filler dust or paint overspray will clog the pump intake filter and may cause internal damage to pump/motor components.

NOTE: Any parts damaged by any type of contamination will not be covered by warranty.

6.6. INSPECTION OF PRESSURE TANK BOTH INSIDE AND OUT

- 6.6.1. Under the PRESSURE SYSTEMS SAFETY REGULATIONS 2000 it is the responsibility of the owner of the compressor to initiate a system of inspection that both defines the frequency of the inspection and appoints a person who has specific responsibility for carrying out the inspection.

6.7. SCHEDULED MAINTENANCE TABLE

MAINTENANCE	Daily	100 Hours	200 Hours	300 Hours	500 Hours
Drain condensation	●				
Check oil level		●	●	●	
Clean air filters		●		●	
Check for oil leaks		●			
Check cut-out			●		●
Replace oil					●
Replace air filters					●
Check tube fittings and electrical connections					●

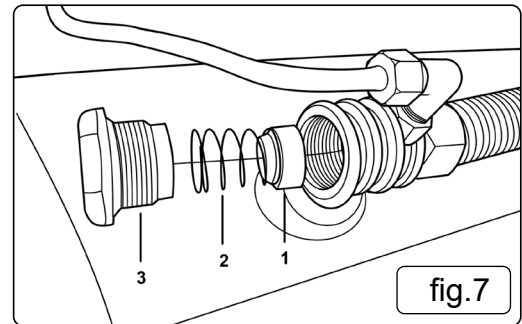

7. TROUBLESHOOTING

FAULT	CAUSE	REMEDY
Pressure drop in the tank.	<ol style="list-style-type: none"> 1. Air leaks at connections. 2. Air leaks from cylinder head gasket. 	<ol style="list-style-type: none"> 1. Run compressor to maximum pressure, switch off. Brush soap solution over connections and look for bubbles. Tighten connections showing leaks. If problem persists, contact Authorised Service Agent. 2. Check tightness of head bolts, if leak continues contact Authorised Service Agent.
Pressure switch valve leaks when compressor is idle.	Non-return valve seal defective.	Empty the air tank. Referring to (fig.7), remove the non-return valve cap (fig.7.3), spring (fig.7.2) and seal (fig.7.1). Clean the seal and its seat, or if necessary replace the seal and refit.
Air leaks from tank body or tank welds.	Internal corrosion caused by infrequent tank draining or non permitted modifications to tank.	Tank could rupture or explode. Cannot be repaired. DISCONTINUE USE IMMEDIATELY.
Motor stops and will not restart.	<ol style="list-style-type: none"> 1. Thermal cut out has operated. 2. Supply fuse has tripped. 	<ol style="list-style-type: none"> 1. Allow unit to cool for 30 minutes then press reset button. 2. Reset fuse and restart unit. If repeated tripping occurs, replace the check valve or contact Authorised Service Agent.
Compressor stops and will not restart.	Motor failure.	Contact Authorised Service Agent.
Compressor does not stop at maximum pressure.	<ol style="list-style-type: none"> 1. Pressure switch fault. 2. Filter clogged 3. Head gasket or valve fault 	<ol style="list-style-type: none"> 1. Contact Authorised Service Agent. 2. Replace filter element. 3. Contact Authorised Service Agent.
Compressor noisy with metallic knock.	Bearing or piston damage.	Contact Authorised Service Agent.
Excessive moisture in discharged air.	High humidity environment.	Drain tank after each use.



ENVIRONMENT PROTECTION

Recycle unwanted materials instead of disposing of them as waste. All tools, accessories and packaging should be sorted, taken to a recycling centre and disposed of in a manner which is compatible with the environment. When the product becomes completely unserviceable and requires disposal, drain any fluids (if applicable) into approved containers and dispose of the product and fluids according to local regulations.



WEEE REGULATIONS

Dispose of this product at the end of its working life in compliance with the EU Directive on Waste Electrical and Electronic Equipment (WEEE). When the product is no longer required, it must be disposed of in an environmentally protective way. Contact your local solid waste authority for recycling information.

NOTE: It is our policy to continually improve products and as such we reserve the right to alter data, specifications and component parts without prior notice. Please note that other versions of this product are available. If you require documentation for alternative versions, please email or call our technical team on technical@sealey.co.uk or 01284 757505.

IMPORTANT: No Liability is accepted for incorrect use of this product.

WARRANTY: Guarantee is 12 months from purchase date, proof of which is required for any claim.

Sealey Group, Kempson Way, Suffolk Business Park, Bury St Edmunds, Suffolk. IP32 7AR



01284 757500



sales@sealey.co.uk



www.sealey.co.uk