



DIRECT DRIVE COMPRESSOR (90LTR/3.0HP)

MODEL NO: **SAC1903B**

Thank you for purchasing a Sealey product. Manufactured to a high standard, this product will, if used according to these instructions, and properly maintained, give you years of trouble free performance.

IMPORTANT: PLEASE READ THESE INSTRUCTIONS CAREFULLY. NOTE THE SAFE OPERATIONAL REQUIREMENTS, WARNINGS & CAUTIONS. USE THE PRODUCT CORRECTLY AND WITH CARE FOR THE PURPOSE FOR WHICH IT IS INTENDED. FAILURE TO DO SO MAY CAUSE DAMAGE AND/OR PERSONAL INJURY AND WILL INVALIDATE THE WARRANTY. KEEP THESE INSTRUCTIONS SAFE FOR FUTURE USE.



Refer to instructions



Wear eye protection



Wear ear protection



Electrical shock hazard



Hot surfaces



Warning!
Automatic start up

1. SAFETY

1.1. ELECTRICAL SAFETY

- ❑ **WARNING!** It is the user's responsibility to check the following:
Check all electrical equipment and appliances to ensure that they are safe before using. Inspect power supply leads, plugs and all electrical connections for wear and damage. Sealey recommend that an RCD (Residual Current Device) is used with all electrical products. You may obtain an RCD by contacting your local Sealey stockist.

If the product is used in the course of business duties, it must be maintained in a safe condition and routinely PAT (Portable Appliance Test) tested.

Electrical safety information, it is important that the following information is read and understood.

- 1.1.1. Ensure that the insulation on all cables and on the appliance is safe before connecting it to the power supply.
- 1.1.2. Regularly inspect power supply cables and plugs for wear or damage and check all connections to ensure that they are secure.
- 1.1.3. **Important:** Ensure that the voltage rating on the appliance suits the power supply to be used and that the plug is fitted with the correct fuse - see fuse rating in these instructions.
 - × **DO NOT** pull or carry the appliance by the power cable.
 - × **DO NOT** pull the plug from the socket by the cable.
 - × **DO NOT** use worn or damaged cables, plugs or connectors. Ensure that any faulty item is repaired or is replaced immediately by a qualified electrician.

- 1.1.4. This product is fitted with a BS1363/A 13 Amp 3 pin plug.
If the cable or plug is damaged during use, switch the electricity supply and remove from use. Ensure that repairs are carried out by a qualified electrician.
Replace a damaged plug with a BS1363/A 13 Amp 3 pin plug. If in doubt contact a qualified electrician.
 - a) Connect the GREEN/YELLOW earth wire to the earth terminal 'E'.
 - b) Connect the BROWN live wire to the live terminal 'L'.
 - c) Connect the BLUE neutral wire to the neutral terminal 'N'.Ensure that the cable outer sheath extends inside the cable restraint and that the restraint is tight. Sealey recommend that repairs are carried out by a qualified electrician.

1.2. GENERAL SAFETY

- ✓ Familiarise yourself with the application and limitations of the compressor.
- ✓ Ensure the compressor is in good order and condition before use. If in any doubt do not use the unit and contact an electrician/service agent.
- ❑ **WARNING! Compressor must only be serviced by an authorised agent. DO NOT tamper with, or attempt to adjust, pressure switch or safety valve.**
- ✓ Before moving, or maintaining the compressor ensure it is unplugged from the mains supply and that the air tank pressure has been vented.
- ✓ Maintain the compressor in good condition and replace any damaged or worn parts. Use genuine parts only. *Unauthorised parts may be dangerous and will invalidate your warranty.*
- ✓ Read the instructions relating to any accessory to be used with this compressor. Ensure the safe working pressure of any air appliance used exceeds compressors output pressure. If using a spray gun, check that the area selected for spraying is provided with an air change system/ventilation.
- ✓ Ensure the air supply valve is turned off before disconnecting the air supply hose.
- ✓ To move the compressor use the handle only. Bear in mind that the compressor has a high centre of gravity. **DO NOT** attempt to lift or move the compressor by any other means.
- ✓ Use the compressor in a well ventilated area and ensure it is placed on a firm surface.
- ✓ Keep tools and other items away from the compressor when it is in use, and keep area clean and clear of unnecessary items.
- ✓ Ensure the air hose is not tangled, twisted or pinched.

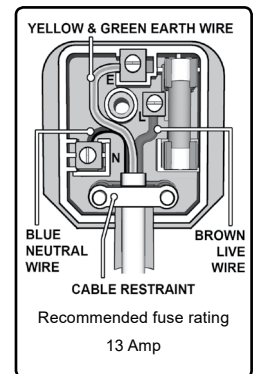

- ✓ Keep children and unauthorised persons away from the working area.
- ✗ **DO NOT** dis-assemble compressor for any reason. The unit must be checked by qualified personnel only.
- ✗ **DO NOT** use the compressor outdoors, or in damp, or wet, locations.
- ✗ **DO NOT** operate within the vicinity of flammable liquids, gases or solids.
- ✗ **DO NOT** touch compressor cylinder, cylinder head or pipe from head to tank as these may be hot and will remain so for some time after shutdown.
- ✗ **DO NOT** use this product to perform a task for which it has not been designed.
- ✗ **DO NOT** deface the certification plate attached to the compressor tank.
- ✗ **DO NOT** cover the compressor or restrict air flow around the unit whilst operating.
- ▲ **DANGER! DO NOT** direct the output jet of air towards people or animals.
- ✗ **DO NOT** operate the compressor without an air filter.
- ✗ **DO NOT** allow anyone to operate the compressor unless they have received full instructions.
- **WARNING!** The air tank is a pressure vessel and the following safety measures apply:
 - ✗ **DO NOT** tamper with the safety valve, **DO NOT** modify or alter the tank in any way and **DO NOT** strap or weld anything to the tank.
 - ✗ **DO NOT** subject the tank to impact, vibration or to heat and **DO NOT** allow contact with abrasives or corrosives.
- ✓ Drain condensation from tank daily and inspect both inside and outside walls for corrosion as stated in the maintenance schedule in section 6. The tank shell must not fall below the certified thickness at any point.
- **WARNING!** If an electrical fuse blows, ensure it is replaced with an identical fuse type and rating.
- ✓ When not in use, store the compressor carefully in a safe, dry, childproof location.
- ✓ When the compressor is not in use, it should be switched off, disconnected from the mains supply and the air drained from the tank.

2. INTRODUCTION

Suitable for the professional workshop, this compressor is fitted with a genuine 3hp motor. Twin capacitors and a centrifugal switch aid trouble free start on a 13Amp supply. Pump features a heavy duty full cast cylinder capped by an alloy head for improved heat dissipation and long life. Heavy-duty drive guard protects belt and flywheel that is designed to force air over the pump to aid cooling. Supplied with full CE certification, test certificates and operation / maintenance manual.

3. SPECIFICATION

Model:	SAC1903B
Motor Output (HP):	3
Voltage/Phase:	230/1
Input current:	13A
Speed (rpm):	1636
Air Displacement (cfm/Lm):	13.4/380
Max Free Air Delivery (cfm/Lm):	9.2/275
Max Pressure (psi/bar):	145/10
Tank Capacity (L):	90
Dimensions (WxDxH) (mm):	525x495x1130
Weight (kg):	65
Noise (dB.A):	74
Noise LwA (dB.A):	96

4. PREPARATION

- 4.1. Remove compressor from packaging and inspect for any shortages or damage. If anything is found to be missing or damaged contact your supplier.
- 4.2. Save the packing material for future transportation of the compressor. We recommend that you store the packing in a safe location, at least for the period of the guarantee. Then, if necessary, it will be easier to send the compressor to the service centre.
- 4.3. Confirm that the mains voltage corresponds with the voltage shown on the compressor data plate.
- 4.4. **As this compressor has a higher centre of gravity compared to horizontally orientated models it should only be used on a sound and level surface.** Take great care when moving the compressor and do not leave it on an incline during transit. Site in a well ventilated area, protected against atmospheric pollution and not in a place subject to explosion hazard. Check if the compressor moves whilst in operation – if it does, secure the wheels with two wedges. If the surface is in a raised position, make sure it cannot fall, securing it in a suitable way.
- 4.5. **To ensure good ventilation and efficient cooling, the compressor's belt guard must be at least 100cm from any wall.**
- 4.6. Take care to transport the compressor correctly, **DO NOT** over turn it or lift it with hooks or ropes.
- 4.7. Remove the plastic transit plug from the oil filler hole (fig.3) and replace it with the filler/breather plug. It is a push fit, ensure that it is pushed fully home.
- 4.8. Before using the compressor, check the oil level by observing the sight glass as shown in fig.2. If the oil is not up to the max mark it should be topped up with synthetic oil suitable for temperatures ranging from -5°C to 45°C (viscosity 5W50).

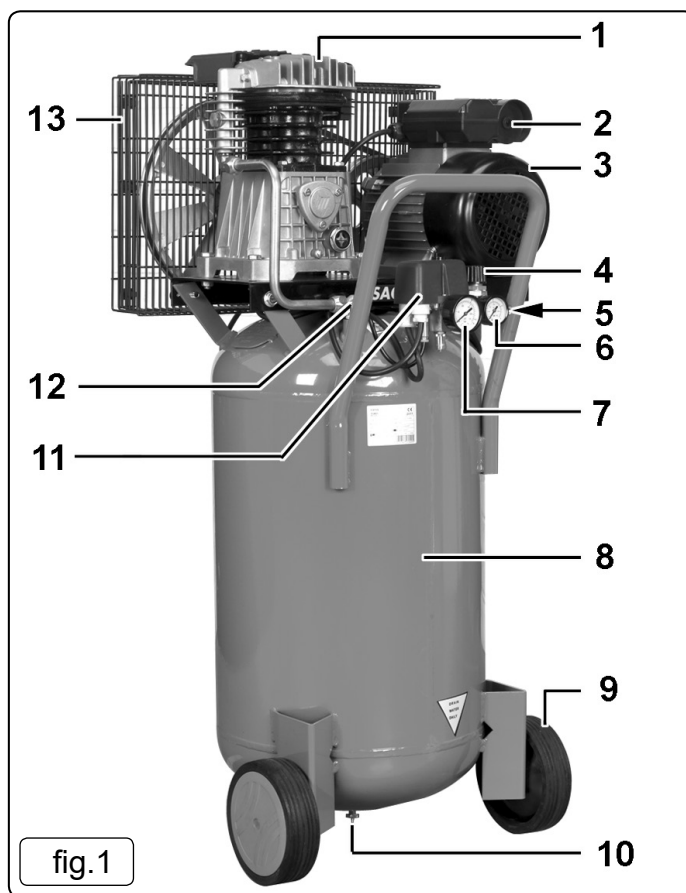

SA1903B KEY:	
1. Compressor Unit	7. Tank pressure gauge
2. Motor thermal reset button	8. Tank
3. Electric motor	9. Wheel
4. Pressure reducer	10. Condensate drain valve
5. Compressed air outlet	11. Pressure switch
6. Output pressure gauge	12. Check valve
	13. Belt guard

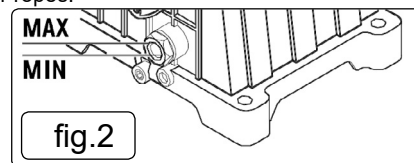

We **DO NOT** recommend using mineral oil in this compressor. **DO NOT** overfill.

5. OPERATION

- ❑ **WARNING!** Ensure that you have read, understood and apply Section 1 safety instructions.
- ❑ **IMPORTANT!** The use of extension leads to connect this compressor to the mains is not recommended as the resulting voltage drop reduces motor, and therefore pump performance, and could cause damage to the compressor.

NOTE: Take care when selecting tools for use with the compressor. Air tool manufacturers normally express the volume of air required to operate a tool in cubic feet per minute (cfm). This refers to free air delivered by the compressor ('air out') which varies according to the pressure setting. **DO NOT** confuse this with the compressor displacement which is the air taken in by the compressor ('air in'). 'Air out' is always less than 'air in' due to losses within the compressor.

5.1. STARTING THE COMPRESSOR

5.1.1. To turn the compressor on, use the switch on the top of the pressure switch housing (figs.4.1). Turn the switch clockwise to position 'I' to start the compressor and anti-clockwise to position 'O' to stop it.

5.1.2. Check that the ON/OFF switch is in the 'O' position. The pressure regulator (fig.4.2) should be closed and the output gauge (fig.4.4) must read Zero '0' bar.

5.1.3. Plug into mains supply and start the compressor by turning the switch to the 'I' position.

5.1.4. When starting the compressor for the first time, leave it running with no air tools connected to the air outlet. Make sure that pressure in the tank rises and that the compressor stops automatically when the maximum pressure value allowed, written on the plate and shown on the gauge (figs.4.5) is achieved. The compressor will now operate automatically. The pressure switch stops the motor when the maximum tank pressure is reached and restarts it when the pressure falls below the minimum threshold - approx. 2bar (29psi) less than the maximum pressure.

5.1.5. Stop the compressor by turning the main switch to the 'O' position (fig.4.1). The compressed air inside the compressor head will flow out, making the restart easier and preventing the motor from being damaged. **DO NOT**, other than in an emergency, stop the compressor by switching off the mains socket, or by pulling the plug out, as the pressure relief will not then operate and motor damage may result upon restart.

5.1.6. The motor of the compressor is fitted with a thermal breaker located in the housing on top of the motor.

The manual resetting button is located in the end of the housing as shown in fig.7A. When the breaker is tripped, wait for a few minutes and then press the reset button.

5.1.7. The output pressure is regulated by the pressure regulator (fig.4.2). Turn the knob clockwise to increase pressure and anti-clockwise to reduce it. Lock knob in position at required pressure with locking ring. To determine the correct working pressure for any piece of equipment check the corresponding manual. When the compressor is not being used, set the regulated pressure to zero so as to avoid damaging the pressure regulator.

NOTE: a) If the motor does not cut in and out, but runs continuously when using an air appliance, the capacity of the compressor may be too small for the equipment or tool.

b) The gauge (fig.4.5) indicates the pressure inside the main tank, NOT the pressure supplied to the air equipment. Should the pressure in the main tank exceed the pre-set switch maximum, the safety valve will activate.

- ❑ **WARNING!** For this reason **DO NOT tamper with, or adjust, the switch or safety valve.**

6. MAINTENANCE

In order to keep the compressor in good working condition, periodic maintenance is essential.

IMPORTANT! Failure to carry out maintenance tasks may invalidate the warranty on your compressor.

- ❑ **WARNING!** Before performing any maintenance operation, switch off the compressor, disconnect from electricity supply and release all air from the tank (except for 6.3.a)

6.1. OPERATIONS TO BE CARRIED OUT AFTER THE FIRST 50 WORKING HOURS:

- a) Check that all bolts/nuts are tight, particularly those retaining the crankcase and cylinder head.
- b) Replace the lubricating oil - see para 6.5.

6.2. OPERATIONS TO BE CARRIED OUT WEEKLY:

a) Drain condensation by opening the valve located under the tank (fig.6). Place a container under the valve and open the valve by turning anti-clockwise.

- ❑ **WARNING!** Take care if there is still pressure inside the cylinder as water could flow out with considerable force. Recommended pressure 1 - 2bar max.
- b) Check oil level and, if necessary, top up.

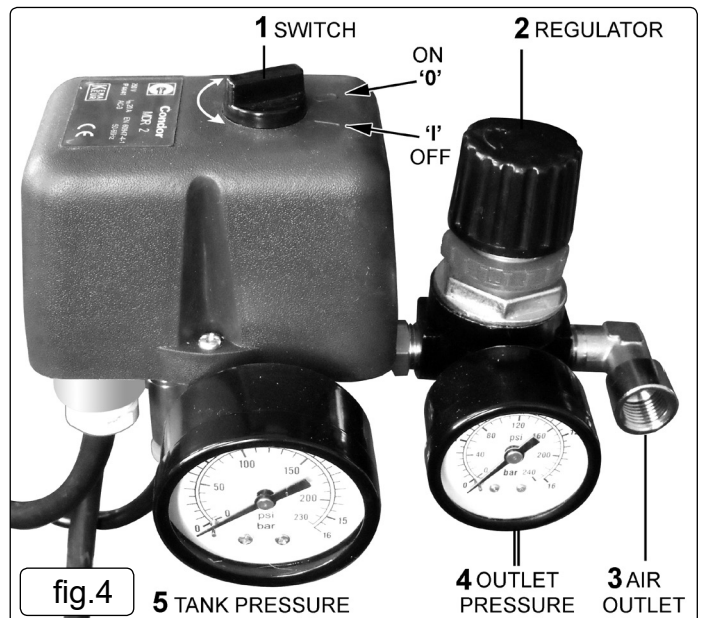
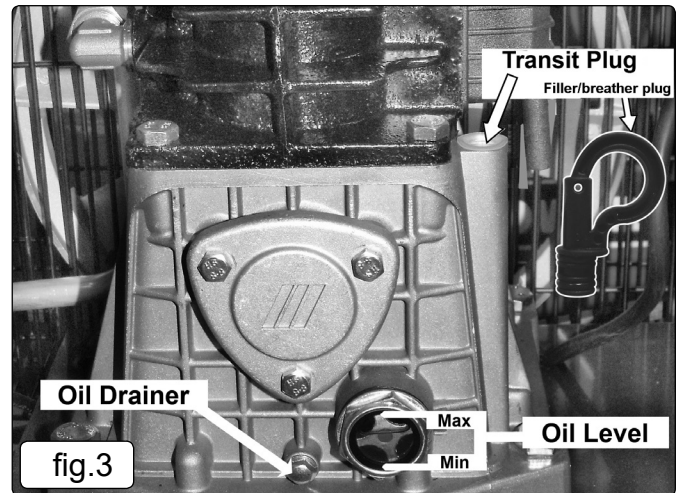

6.3. **OPERATIONS TO BE CARRIED OUT EVERY 50 HOURS:**
(or more frequently, if the compressor operates in a very dusty atmosphere):

- a) Remove the air filter element (fig.5). Using stored air from the compressor's tank, clean the filter with compressed air. (Wear eye protection and **DO NOT** direct air towards the body or hands). **DO NOT** operate the compressor without the filter as foreign bodies or dust could seriously damage the pump. Replace the filter element and air filter housing.
- b) Check for oil leaks.

6.4. **OPERATIONS TO BE CARRIED OUT EVERY 100 HOURS:**

- a) Check the automatic cut-out at max. pressure and the automatic cut-in at 2bar below.

6.5. **OPERATIONS TO BE CARRIED OUT EVERY 400 HOURS:**

- a) Replace the lubricating oil. For oil specifications see 6.6. Remove the filler/breather plug (see fig.3) then remove oil drain plug, draining the oil into a container. Drain when the compressor is hot so that the oil drains rapidly and completely. Incline compressor to ensure complete drainage. Replace oil drain plug and refill through the filler/breather aperture. **DO NOT** overfill. Replace plug.

❑ **WARNING! Never mix different oils and DO NOT use non-detergent/low quality oils as the compressor may be damaged.**

❑ **WARNING! Dispose of waste oil only in accordance with local authority requirements.**

- b) Replace air filter (See fig.5).
- c) Check all tube fittings and electrical connections.
- d) Inspect pressure tank inside and out for damage or corrosion.

6.6. **RECOMMENDED OILS**

Synthetic oil suitable for temperatures ranging from -5°C to 45°C: viscosity 5W50. We **DO NOT** recommend using mineral oil in these compressors.

Part No.	Qty.	Description
FSO1	1ltr x 12	Compressor oil fully synthetic
FSO1S	1ltr x 1	Compressor oil fully synthetic
FSO5	5ltr x 1	Compressor oil fully synthetic

Maintenance Operations	Weekly	50hrs	100hrs	400 hrs
Drain condensation	●			
Check oil level	●			
Clean intake filter		●		
Check for oil leaks		●		
Replace oil				●
Check cut-out			●	
General cleaning of compressor			●	
Replace air filter				●
Check tube fittings and electrical connections				●
Internal & external inspection of tank				●

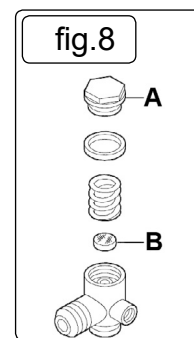
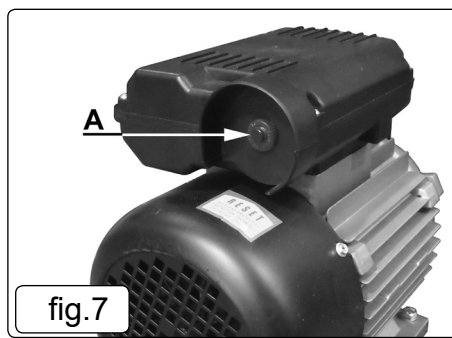
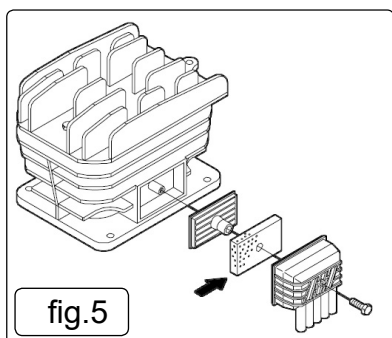

6.7. **IMPORTANT WARNING** - Air contaminants taken into the compressor will affect optimum performance. Example: Body filler dust or paint overspray will clog the pump intake filter and may cause internal damage to pump/motor components. Please note that any parts damaged by any type of contamination will not be covered by warranty.

7. TROUBLE SHOOTING

Fault	Cause	Remedy
Pressure drop in the tank.	Air leaks at connections.	Run compressor to max. pressure, switch off. Brush soap solution over connections and look for bubbles. Tighten connections showing leaks. If problem persists contact Authorised Service Agent.
Pressure switch valve leaks when compressor is idle.	Non-return valve seal defective.	Discharge all tank pressure. Referring to fig.8, unscrew valve cap 'A'. Clean rubber disc 'B' and its seat. Refit all parts accurately.
Compressor stops and does not restart.	Power failure. Motor failure.	Check electricity supply and fuse. Contact Authorised Service Agent.
Compressor does not stop at max pressure.	Pressure switch fault.	Contact Authorised Service Agent.
Compressor does not reach max pressure.	Filter clogged. Head gasket or valve fault.	Replace filter element. Contact Authorised Service Agent.
Compressor noisy with metallic knock.	Low oil level. Bearing or piston damage.	Turn off and top up oil immediately. Contact Authorised Service Agent.



ENVIRONMENT PROTECTION

Recycle unwanted materials instead of disposing of them as waste. All tools, accessories and packaging should be sorted, taken to a recycling centre and disposed of in a manner which is compatible with the environment. When the product becomes completely unserviceable and requires disposal, drain any fluids (if applicable) into approved containers and dispose of the product and fluids according to local regulations.



WEEE REGULATIONS

Dispose of this product at the end of its working life in compliance with the EU Directive on Waste Electrical and Electronic Equipment (WEEE). When the product is no longer required, it must be disposed of in an environmentally protective way. Contact your local solid waste authority for recycling information.

Note: It is our policy to continually improve products and as such we reserve the right to alter data, specifications and component parts without prior notice.

Important: No Liability is accepted for incorrect use of this product.

Warranty: Guarantee is 12 months from purchase date, proof of which is required for any claim.

Sealey Group, Kempson Way, Suffolk Business Park, Bury St Edmunds, Suffolk. IP32 7AR



01284 757500



01284 703534



sales@sealey.co.uk



www.sealey.co.uk