

Thank you for purchasing a Sealey product. Manufactured to a high standard this product will, if used according to these instructions and properly maintained, give you years of trouble free performance.



IMPORTANT: PLEASE READ THESE INSTRUCTIONS CAREFULLY. NOTE THE SAFE OPERATIONAL REQUIREMENTS, WARNINGS & CAUTIONS. USE THE PRODUCT CORRECTLY AND WITH CARE FOR THE PURPOSE FOR WHICH IT IS INTENDED. FAILURE TO DO SO MAY CAUSE DAMAGE AND/OR PERSONAL INJURY AND WILL INVALIDATE THE WARRANTY. PLEASE KEEP INSTRUCTIONS SAFE FOR FUTURE USE.

The use of symbols in this document is to attract your attention to possible danger. The symbols and warnings themselves do not eliminate any danger, nor are they substitutes for correct accident prevention measures.

1. SAFETY INSTRUCTIONS

1.1. ELECTRICAL SAFETY

WARNING! It is the responsibility of the owner and the operator to read, understand and comply with the following:

You must check all electrical products, before use, to ensure that they are safe. You must inspect power cables, plugs, sockets and any other connectors for wear or damage. You must ensure that the risk of electric shock is minimised by the installation of appropriate safety devices. A Residual Current Circuit Breaker (RCCB) should be incorporated in the main distribution board. We also recommend that a Residual Current Device (RCD) is used. It is particularly important to use an RCD with portable products that are plugged into a supply which is not protected by an RCCB. If in any doubt consult a qualified electrician. You may obtain a Residual Current Device by contacting your Sealey dealer. **You must also read and understand the following instructions concerning electrical safety.**

- 1.1.1. The **Electricity at Work Act 1989** requires all portable electrical appliances, if used on business premises, to be tested by a qualified electrician, using a Portable Appliance Tester (PAT), at least once a year.
- 1.1.2. The **Health & Safety at Work Act 1974** makes owners of electrical appliances responsible for the safe condition of those appliances and the safety of the appliance operators. **If in any doubt about electrical safety, contact a qualified electrician.**
- 1.1.3. Ensure that the insulation on all cables and on the appliance is safe before connecting it to the power supply. See 1.1.1. and 1.1.2. and use a Portable Appliance Tester.
- 1.1.4. Ensure that cables are always protected against short circuit and overload.
- 1.1.5. Regularly inspect power supply cables and plugs for wear or damage and check all connections to ensure that none is loose.
- 1.1.6. **Important:** Ensure that the voltage marked on the appliance matches the power supply to be used and that the plug is fitted with the correct fuse - see fuse rating at right.
- 1.1.7. **DO NOT** pull or carry the appliance by the power cable.
- 1.1.8. **DO NOT** pull the plug from the socket by the cable.
- 1.1.9. **DO NOT** use worn or damaged cables, plugs or connectors. Immediately have any faulty item repaired or replaced by a qualified electrician. When an ASTA/BS approved UK 3 pin plug is damaged, cut the cable just above the plug and **dispose of the plug safely.** Fit a new plug according to the following instructions (UK only).

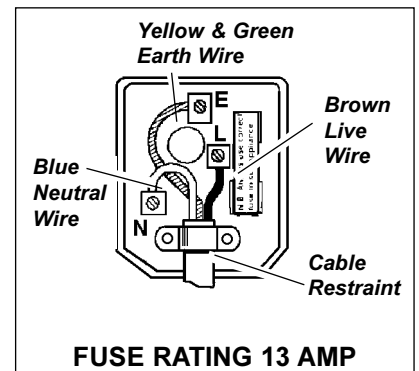

a) Connect the **GREEN/YELLOW** earth wire to the earth terminal 'E'.

b) Connect the **BROWN** live wire to the live terminal 'L'.

c) Connect the **BLUE** neutral wire to the neutral terminal 'N'.

d) **After wiring, check that there are no bare wires, that all wires have been correctly connected, that the cable outer insulation extends beyond the cable restraint and that the restraint is tight.**

Double insulated products, which are always marked with this symbol , are fitted with live (brown) and neutral (blue) wires only. To rewire, connect the wires as indicated above - **DO NOT** connect either wire to the earth terminal.

- 1.1.10. Products which require more than 13 amps are supplied without a plug. In this case you must contact a qualified electrician to ensure that a suitably rated supply is available. We recommend that you discuss the installation of an industrial round pin plug and socket with your electrician.
- 1.1.11. If an extension reel is used it should be fully unwound before connection. A reel with an RCD fitted is preferred since any appliance plugged into it will be protected. The cable core section is important and should be at least 1.5mm², but to be absolutely sure that the capacity of the reel is suitable for this product and for others which may be used in the other output sockets, we recommend the use of 2.5mm² section cable. If extension reel is to be used outdoors, ensure it is marked for outdoor use.

1.2. GENERAL SAFETY INSTRUCTIONS

Familiarise yourself with the application and limitations of the compressor.

Ensure the compressor is in good order and condition before use. If in any doubt do not use the unit and contact an electrician/service agent.

WARNING! Compressor must only be serviced by an authorised agent. DO NOT tamper with, or attempt to adjust pressure switch or safety valve.

Before moving, or maintaining the compressor ensure it is unplugged from the mains supply and that the air tank pressure has been vented.

Only use recommended attachments and parts. To use non-recommended items may be dangerous and will invalidate your warranty.

Read the instructions regarding any accessory used with the compressor. Ensure the safe working pressure of any air appliance used, exceeds units output pressure. If using spray gun, check the area selected for spraying is provided with air change system/ventilation.

Ensure the air supply valve is turned off before disconnecting the air supply hose.

To move the compressor use the handle only. Lift the compressor so that the front leg gives enough clearance for manoeuvring but maintain units centre of gravity in front of the wheels. **DO NOT** attempt to lift or move the compressor by any means other than by handle.

Use the compressor in a well ventilated area and ensure it is placed on a firm surface.

Keep tools and other items away from the compressor when it is in use, and keep area clean and clear of unnecessary items.

Ensure the air hose is not tangled or twisted, or pinched.

Keep children and unauthorised persons away from the working area.

DO NOT dis-assemble compressor for any reason. The unit must be checked by qualified personnel only.

DO NOT use the compressor outdoors, or in damp, or wet locations, and **DO NOT** operate within the vicinity of flammable liquids, gases or solids.

DO NOT touch compressor cylinder, cylinder head or pipe from head to tank as these may be hot and will remain so for some time after shutdown.

DO NOT attempt to move the compressor by pulling the air tool's hose. Only move the compressor by its handle.

DO NOT use this product to perform a task for which it has not been designed.

DO NOT deface the certification plate attached to the end of the compressor tank.

DO NOT cover the compressor or restrict air flow around the machine whilst operating.
▲ DANGER! DO NOT direct the output jet of air towards people or animals.
 DO NOT operate the compressor without an air filter.
 DO NOT allow anyone to operate the compressor unless they have received full instructions.

☐ WARNING! The air tank is a pressure vessel and the following safety measures apply:

DO NOT tamper with the safety valve.
DO NOT modify or alter the tank in any way and DO NOT strap anything to the tank.
DO NOT subject the tank to impacts, vibration or to heat.
DO NOT allow contact with abrasives or corrosives.
DO drain condensation from tank daily and inspect inside walls for corrosion every 12 months.

The tank shell must not fall below the certified thickness at any point.

☐ WARNING! If an electrical fuse blows, ensure it is replaced with an identical fuse type and rating.

When not in use, store the compressor carefully in a safe, dry, childproof location.

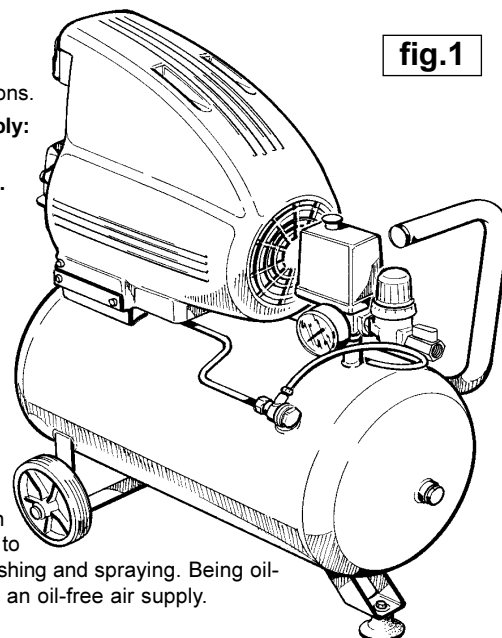

fig.1

2. INTRODUCTION & SPECIFICATION

The SA9825/1.5 Oil-free Compressor has a single cylinder pump powered by a 230V 1ph motor and is capable of supplying air at up to 8 bar from a 25 litre tank. In addition to pneumatic tools, the compressor may be connected to accessories suitable for blowing, washing and spraying. Being oil-free simplifies and reduces servicing, allows operation in inclined positions and provides an oil-free air supply.

2.1. SPECIFICATION

Model	Motor Output (hp)	Voltage/Phase	Current (A)	Pump Type	Pump Speed (rpm)	Piston Displacement (cfm)	Free Air Delivery (cfm)			Tank Capacity (l)	Max. Pressure (psi/bar)	Noise Level (dB.A)
							Max.	At 2.5 Bar*	At 6.0 Bar*			
OIL-FREE 25 SA9825/1.5	1.5	230/1	6.5	D8	2850	6.7	5.9	5.6	4.2	25	116/8	81

* Note: 2.5 bar is recommended pressure setting for spraying
 6.0 bar is recommended pressure setting for air tools

Model	Weight (kg)	Dimensions Length x Width x Height (mm)
OIL-FREE 25	20	600 x 265 x 595

3. PREPARATION

- 3.1. Remove compressor from packaging and inspect for any shortages or damage. If anything is found to be missing or damaged contact your supplier.
- 3.2. Save the packing material for future transportation of the compressor. We recommend that you store the packing in a safe location, at least for the period of the guarantee. Then, if necessary, it will be easier to send the compressor to the service centre.
- 3.3. Confirm that the mains voltage corresponds with the voltage shown on the compressor data plate.
- 3.4. The compressor should be operated in a position that allows good air circulation around the unit.
- 3.5. Referring to the compressor parts diagram attach the wheels to the tank frame using the axle bolts and nuts provided.
- 3.6. Referring to the compressor parts diagram attach the rubber foot to the tank frame using the fittings provided.

4. OPERATION

☐ WARNING! Ensure that you have read, understood and apply Section 1 safety instructions.

4.1. STARTING THE COMPRESSOR.

Your compressor will be fitted with one of two types of ON/OFF switch.

ROTARY ON/OFF. The switch may be of the rotary type as shown in fig.A. To turn the compressor 'on' rotate the switch from the 'OFF' position to the 'AUTO' position.

PULL ON/PUSH OFF. The switch may be of the push/pull type as shown in fig.2-1. To turn the compressor 'ON' pull the switch knob upwards. To turn the compressor 'OFF' push the knob downwards.

4.1.1. Check that the ON/OFF switch is in the "OFF" position, the regulator tap (3) is closed (Zero '0' bar), and tap (4) is OFF.

4.1.2. Plug the compressor into the electrical mains supply and start the machine by moving the ON/OFF switch to the ON/AUTO position.

4.1.3. Compressor will now operate and automatically build up the pressure in the tank to the maximum pressure set at the factory and may be monitored by reading pressure gauge (2). When the maximum tank pressure is reached, the pressure switch (6) will automatically switch the motor off. When pressure falls below the minimum threshold (approx. 2 bar (29psi) less than the maximum pressure), the pressure switch (6) will automatically cut in and start the motor again thus building the pressure back to maximum.

NOTE:

- a) If the motor does not cut in and out, but runs continuously when using an air appliance, the capacity of the compressor may be too small for the equipment or tool.
- b) The gauge (2) indicates the pressure inside the main tank, NOT the pressure supplied to the air equipment. Should the pressure in the main tank exceed the pre-set switch (6) maximum, a safety release valve (5) will activate. (The valve is shown as part no.2 on the compressor parts diagram).

WARNING! for this reason DO NOT tamper with or adjust the switch or valve unit.

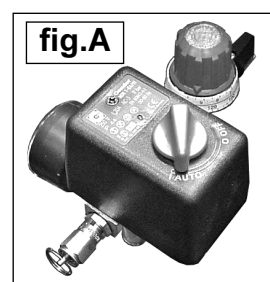

fig.A

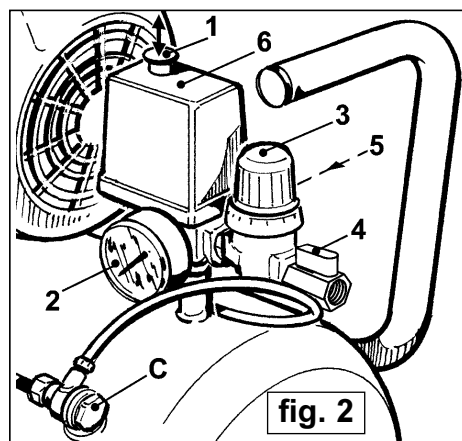

fig. 2

4.2. STOPPING THE COMPRESSOR

To stop the compressor move the ON/OFF switch to the OFF/down position. This switch will stop the motor and open a breather valve to release pressure from the motor head, which makes restart easier and prevents the motor from being damaged.
CAUTION! DO NOT turn off from the electrical mains power switch (other than in an emergency), as the head pressure relief will not occur.

4.3. CONNECTING AIR POWERED EQUIPMENT.

- 4.3.1. After fitting the desired coupling to tap (fig 2.4) connect other end of the hose to the air equipment.
 4.3.2. Turn the regulator valve (fig 2.3) to the required output pressure (in accordance with the air equipment instructions) by lifting and turning regulator clockwise. Push the valve into corresponding slot to lock into the required pressure.
 Turn tap (4) 'ON'.

CAUTION: Lift valve to turn pressure up or down. DO NOT try to turn valve if locked in slot as this may damage valve seal.

NOTE: To determine the correct working pressure and air flow requirements for any piece of equipment check the corresponding manual. Be aware that the air flow figure stated on tools and accessories refers to 'Free Air Delivery' and not the piston displacement of the compressor.

- 4.3.3. To disconnect equipment, turn the regulator valve anti-clockwise to 'Zero' (0) bar. Pull the air equipment's trigger to release pressure and disconnect air hose from compressor.

4.4. WHEN WORK IS COMPLETE

At the end of each working day, drain any moisture from the main tank. Place a container under the drain valve on the underside of the tank (fig 3) and carefully unscrew the drain valve to allow any moisture to escape. When moisture ceases to come out screw the valve back up again ensuring that it reseals. DO NOT allow moisture to accumulate in the tank as this will corrode the inside and effect the tanks pressure rating.

WARNING! wear safety goggles when performing this task.

NOTE: As the condensate is 'oil-free' it may be disposed of through the normal sewage system.

fig. 3

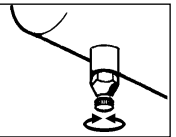

5. MAINTENANCE

In order to keep the compressor in good working condition, periodic maintenance is essential.

WARNING! service and maintenance must be performed by an authorised agent. DO NOT tamper with, or attempt to adjust pressure switch or safety valve. Before moving, or carrying out any maintenance on the compressor ensure that it is unplugged from the mains power supply and that the air tank pressure has been vented.

5.1. GENERAL WORKSHOP MAINTENANCE.

At the end of each working day, drain any moisture from the main tank as described above in section 4.4

WARNING! wear safety goggles when performing this task.

NOTE: As the condensate is 'oil-free' it may be disposed of through the normal sewage system.

fig. 4

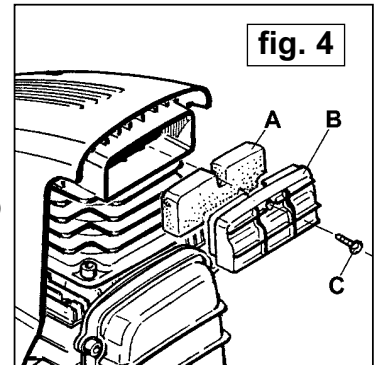

5.2. INLET FILTER (fig 4.A).

Clean the inlet filter every 100 hours. Release the filter cover (B) by undoing retaining screw (C) and removing the sponge filter (A). Wash filter in clean water, thoroughly dry and replace. Renew the filter after every 500 hours of use, or more frequently if used in a dusty environment. **Note:** Do not operate compressor without suction filter as foreign bodies or dust may seriously damage pump.

5.3. PISTON RINGS.

To allow oil free air flow the oil-free compressor does not have any oil to minimise friction between moving parts. Tightening rings of 'Teflon' with carbon are on the piston. These rings must be changed every 400 to 500 working hours.

fig. 5

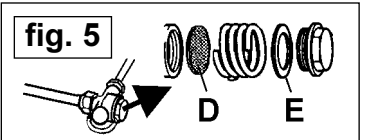

6. TROUBLE SHOOTING

Fault	Cause	Remedy
Pressure drop in the tank	Air leaks at connections	Run compressor to max. pressure, switch off. Brush soap solution over connections and look for bubbles. Tighten connections showing leaks. If problem persists contact Authorised Service Agent.
Pressure switch valve leaks when compressor is idle	Non-return valve seal defective	Empty the air tank, remove the non-return valve (fig 2.C & fig 5) and clean the seat 'D'. If necessary replace the seal 'E'
Safety valve operates below max pressure	Faulty valve	Contact Authorised Service Agent.
Motor works but no air produced	Valves leaking or head gasket damaged	check for leaks, or Contact Authorised Service Agent.
Compressor stops and does not restart	Electrical, Motor or pressure switch failure	Check electrical supply, or Contact Authorised Service Agent.
Compressor does not stop when max. pressure is reached, safety valve operates.	Pressure switch failure or incorrectly set	Contact Authorised Service Agent.
Compressor does not achieve max. pressure and overheats	Head gasket or valve fault	Contact Authorised Service Agent.
Compressor makes metallic rattle	Bearing or piston fault	Contact Authorised Service Agent.

Declaration of Conformity We, the sole UK importer, declare that the product listed below is in conformity with the following standards and directives.

OIL-FREE COMPRESSOR

Model: SA9825/1.5.V2

87/404 EEC Pressure Vessel Directive
89/336 EEC EMC Directive
EN292-2 Machinery Design
IEC 34-1 Motor Rating & Performance
EN60335-1 Electrical Safety



The construction file for this product is held by the Manufacturer and may be inspected by a national authority on request by contacting Jack Sealey Ltd.

Signed by Mark Sweetman

30th April 2004

For Jack Sealey Ltd. Sole UK importer of Sealey Power Products.

NOTE: It is our policy to continually improve products and as such we reserve the right to alter data, specifications and component parts without prior notice.

IMPORTANT: No liability is accepted for incorrect use of this equipment

WARRANTY: Guarantee is 12 months from purchase date, proof of which will be required for any claim.

INFORMATION: For a copy of our latest catalogue and promotions, call us on 01284 757525 and leave your full name and address, including postcode.



Sole UK Distributor
Sealey Group,
Bury St. Edmunds, Suffolk.



Web www.sealey.co.uk



01284 757500



01284 703534



email sales@sealey.co.uk