

MODEL No's:

SA951015

SA952515

SA955015

Thank you for purchasing a Sealey product. Manufactured to a high standard this product will, if used according to these instructions and properly maintained, give you years of trouble free performance.



IMPORTANT: PLEASE READ THESE INSTRUCTIONS CAREFULLY. NOTE THE SAFE OPERATIONAL REQUIREMENTS, WARNINGS, AND CAUTIONS. USE THIS PRODUCT CORRECTLY, AND WITH CARE FOR THE PURPOSE FOR WHICH IT IS INTENDED. FAILURE TO DO SO MAY CAUSE DAMAGE AND/OR PERSONAL INJURY AND WILL INVALIDATE THE WARRANTY.

1. SAFETY INSTRUCTIONS

1.1 ELECTRICAL SAFETY

- ❑ **WARNING!** It is the responsibility of the owner and the operator to read, understand and comply with the following: You must check all electrical products, before use, to ensure that they are safe. You must inspect power cables, plugs, sockets and any other connectors for wear or damage. You must ensure that the risk of electric shock is minimised by the installation of appropriate safety devices. A Residual Current Circuit Breaker (RCCB) should be incorporated in the main distribution board. We also recommend that a Residual Current Device (RCD) is used. It is particularly important to use an RCD with portable products that are plugged into a supply which is not protected by an RCCB. If in any doubt consult a qualified electrician. You may obtain a Residual Current Device by contacting your Sealey dealer.

You must also read and understand the following instructions concerning electrical safety.

- 1.1.1 The **Electricity at Work Act 1989** requires all portable electrical appliances, if used on business premises, to be tested by a qualified electrician, using a Portable Appliance Tester (PAT), at least once a year.
- 1.1.2 The **Health & Safety at Work Act 1974** makes owners of electrical appliances responsible for the safe condition of those appliances and the safety of the appliance operators. **If in any doubt about electrical safety, contact a qualified electrician.**
- 1.1.3 Ensure that the insulation on all cables and on the appliance is safe before connecting it to the power supply. See 1.1.1 and 1.1.2 and use a Portable Appliance Tester.
- 1.1.4 Ensure that cables are always protected against short circuit and overload.
- 1.1.5 Regularly inspect power supply cables and plugs for wear or damage and check all connections to ensure that none is loose.
- 1.1.6 **Important:** Ensure that the voltage marked on the appliance matches the power supply to be used and that the plug is fitted with the correct fuse - see fuse rating at right.
- 1.1.7 **DO NOT** pull or carry the appliance by the power cable.
- 1.1.8 **DO NOT** pull the plug from the socket by the cable.
- 1.1.9 **DO NOT** use worn or damaged cables, plugs or connectors. Immediately have any faulty item repaired or replaced by a qualified electrician. When an ASTA/BS approved UK 3 pin plug is damaged, cut the cable just above the plug and **dispose of the plug safely.** Fit a new plug according to the following instructions (UK only).
 - a) Connect the **GREEN/YELLOW** earth wire to the earth terminal 'E'.
 - b) Connect the **BROWN** live wire to the live terminal 'L'.
 - c) Connect the **BLUE** neutral wire to the neutral terminal 'N'.
 - d) After wiring, check that there are no bare wires, that all wires have been correctly connected, that the cable outer insulation extends beyond the cable restraint and that the restraint is tight.

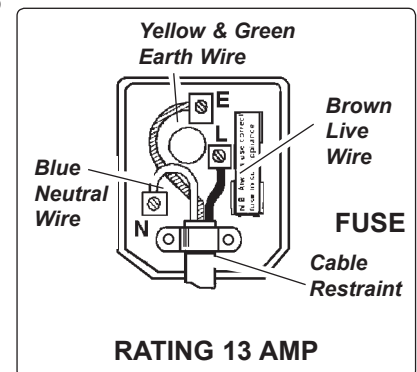

Double insulated products, which are always marked with this symbol , are fitted with live (brown) and neutral (blue) wires only. To rewire, connect the wires as indicated above - **DO NOT** connect either wire to the earth terminal.

- 1.1.10 Products which require more than 13 amps are supplied without a plug. In this case you must contact a qualified electrician to ensure that a suitably rated supply is available. We recommend that you discuss the installation of an industrial round pin plug and socket with your electrician.
- 1.1.11 If an extension reel is used it should be fully unwound before connection. A reel with an RCD fitted is preferred since any appliance plugged into it will be protected. The cable core section is important and should be at least 1.5mm², but to be absolutely sure that the capacity of the reel is suitable for this product and for others which may be used in the other output sockets, we recommend the use of 2.5mm² section cable. If extension reel is to be used outdoors, ensure it is marked for outdoor use.
- 1.2 GENERAL SAFETY INSTRUCTIONS**
- 1.2.1 Familiarise yourself with the application and limitations of the compressor.
- 1.2.2 Ensure the compressor is in good order and condition before use. If in any doubt do not use the unit and contact an electrician/service agent.
- ❑ **WARNING! Compressor must only be serviced by an authorised agent. DO NOT tamper with, or attempt to adjust pressure switch or safety valve.**
- 1.2.3 Before moving, or maintaining the compressor ensure it is unplugged from the mains supply and that the air tank pressure has been vented.
- 1.2.4 Only use recommended attachments and parts. To use non-recommended items may be dangerous and will invalidate your warranty.
- 1.2.5 Read the instructions regarding any accessory used with the compressor. Ensure the safe working pressure of any air appliance used, exceeds units output pressure. If using spray gun, check the area selected for spraying is provided with air change system/ventilation.
- 1.2.6 Ensure the air supply valve is turned off before disconnecting the air supply hose.
- 1.2.7 To move the compressor use the handle only. Lift the compressor so that the front leg gives enough clearance for manoeuvring but maintain units centre of gravity in front of the wheels. **DO NOT** attempt to lift or move the compressor by any means other than by handle.
- 1.2.8 Use the compressor in a well ventilated area and ensure it is placed on a firm surface.
- 1.2.9 Keep tools and other items away from the compressor when it is in use, and keep area clean and clear of unnecessary items.
- 1.2.10 Ensure the air hose is not tangled or twisted, or pinched.
- 1.2.11 Keep children and unauthorised persons away from the working area.
- x **DO NOT** dis-assemble compressor for any reason. This unit must be checked and serviced by an approved service agent.
- x **DO NOT** use the compressor outdoors, or in damp, or wet locations, and **DO NOT** operate within the vicinity of flammable liquids, gases or solids.

- x **DO NOT** attempt to move the compressor by pulling the air tool's hose. Only move the compressor by its handle.
- x **DO NOT** use this product to perform a task for which it has not been designed.
- x **DO NOT** deface the certification plate attached to the tank.
- x **DO NOT** cover the compressor or restrict air flow around the machine whilst operating.
- ▲ **DANGER! DO NOT direct the output jet of air towards people or animals.**
- x **DO NOT** allow anyone to operate the compressor unless they have received full instructions.
- **WARNING! The air tank is a pressure vessel and the following safety measures apply:**
- x **DO NOT tamper with the safety valve.**
- x **DO NOT modify or alter the tank in any way and DO NOT strap anything to the tank.**
- x **DO NOT subject the tank to impacts, vibration or to heat.**
- x **DO NOT allow contact with abrasives or corrosives.**
- ✓ **DO drain condensation from tank daily and inspect inside walls for corrosion every 12 months. The tank shell must not fall below the certified thickness at any point.**
- **WARNING! If an electrical fuse blows, ensure it is replaced with an identical fuse type and rating.**
When not in use, store the compressor carefully in a safe, dry, childproof location.

2. INTRODUCTION & SPECIFICATIONS

Ideal for use where an oil-free air delivery is required and especially suited to small low pressure, touch-up and airbrush spraying applications as well as general-purpose applications. Simple construction with fewer components makes these units practically maintenance-free. Reduced weight gives greater portability and compressor can be transported and even operated on its side. All models are supplied with a precision welded receiver tank, manufactured to meet Pressure Vessel Directive 87/404/EEC, fully automatic pressure cut-out switch and air regulator with gauge. All have a handle and wheels and ASTA/BS approved non-rewirable plug.

Model No:	SA951015	Air Displacement:	6.7cfm
Motor Output:	1.5hp	Max. Free Air Delivery:	5.9cfm
Voltage/Phase:	230V - 1ph	Tank Capacity:	10ltr
Input Current:	5A	Max. Pressure:	116psi/8bar

Model No:	SA952515	Air Displacement:	6.7cfm
Motor Output:	1.5hp	Max. Free Air Delivery:	5.9cfm
Voltage/Phase:	230V - 1ph	Tank Capacity:	25ltr
Input Current:	5A	Max. Pressure:	116psi/8bar

Model No:	SA955015	Air Displacement:	6.7cfm
Motor Output:	1.5hp	Max. Free Air Delivery:	5.9cfm
Voltage/Phase:	230V - 1ph	Tank Capacity:	50ltr
Input Current:	5A	Max. Pressure:	116psi/8bar



3. PREPARATION

- 3.1 Remove compressor from packaging and inspect for any shortages or damage. If anything is found to be missing or damaged contact your supplier.
- 3.2 Save the packing material for future transportation of the compressor. We recommend that you store the packing in a safe location, at least for the period of the guarantee. Then, if necessary, it will be easier to send the compressor to the service centre.
- 3.3 Confirm that the mains voltage supply corresponds with the voltage shown on the compressor data plate.
- 3.4 The compressor should be operated in a position that allows good air circulation around the unit.

4. OPERATION

- ❑ **WARNING! Ensure that you have read, understood and apply Section 1 safety instructions.**

4.1 STARTING THE COMPRESSOR

- 4.1.1 Check that the start button (fig 1.1) is in the "OFF" position (down), the regulator (fig 1.2) is closed (Zero '0' bar), and tap (fig 1.3) is "Closed" (as shown).
- 4.1.2 Plug the compressor into the electrical mains supply and start the machine by moving the start button into the "ON" position (up).
- 4.1.3 The compressor will now operate and automatically build up the pressure in the tank to the maximum pressure set at the factory and may be monitored by reading pressure gauge (fig 1.4). When the maximum tank pressure is reached, the pressure switch (fig 1.5) will automatically switch the motor off. When pressure falls below the minimum threshold (approx. 2 bar (29psi) less than the maximum pressure), the pressure switch (fig 1.5) will automatically cut in and start the motor again, thus building the pressure back to maximum.

NOTE: a) If the motor does not cut in and out, but runs continuously when using an air appliance, the capacity of the compressor may be too small for the equipment or tool.
b) The gauge (fig 1.4) indicates the pressure inside the main tank, NOT the pressure supplied to the air equipment. Should the pressure in the main tank exceed the pre-set switch (fig 1.5) maximum, a safety release valve (fig 1.6) will activate.

WARNING! for this reason DO NOT tamper with or adjust the switch or valve unit.

4.2 STOPPING THE COMPRESSOR

To stop the compressor, move the start button to the "OFF" position (down). This switch will stop the motor and open a breather valve to release pressure from the motor head, which makes restart easier and prevents the motor from being damaged.

CAUTION! DO NOT turn off from the electrical mains power switch (other than in an emergency), as the head pressure relief will not occur.

4.3 CONNECTING AIR POWERED EQUIPMENT

- 4.3.1 After fitting the desired coupling to tap (fig 1.3) connect other end of the hose to the air equipment.
- 4.3.2 Turn the regulator valve (fig 1.2) to the required output pressure. The pressure applied to the tool is shown on the output pressure gauge (fig 1.7).
- 4.3.3 Turn on tap (fig 1.3).

NOTE: To determine the correct working pressure and air flow requirements for any piece of equipment check the corresponding manual. Be aware that the air flow figure stated on tools and accessories refers to 'Free Air Delivery' and not the piston displacement of the compressor.

- 4.3.4 To disconnect equipment, turn the regulator valve (fig 1.2) anti-clockwise to 'Zero' (0) bar. Pull the air equipment's trigger to release pressure and then disconnect air hose from compressor. Relieve any pressure remaining in the compressor by manually operating the pressure relief button situated below the compressor's air outlet. Push the button inwards to relieve the pressure.

4.4 WHEN WORK IS COMPLETE

Ensure the the compressor is switched off and the pressure is released before draining the tank.

At the end of each working day, drain any moisture from the main tank. Place a container under the drain valve on the underside of the tank (fig 2) and carefully unscrew the drain valve to allow any moisture to escape. When moisture ceases to come out screw the valve back up, again ensuring that it re-seals. **DO NOT** allow moisture to accumulate in the tank as this will corrode the inside and affect the tank's pressure rating.

WARNING! Wear safety goggles when performing this task.

NOTE: As the residue is oil-free it may be disposed of through the normal sewage system.

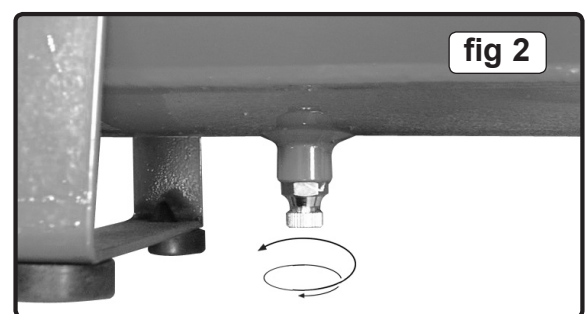
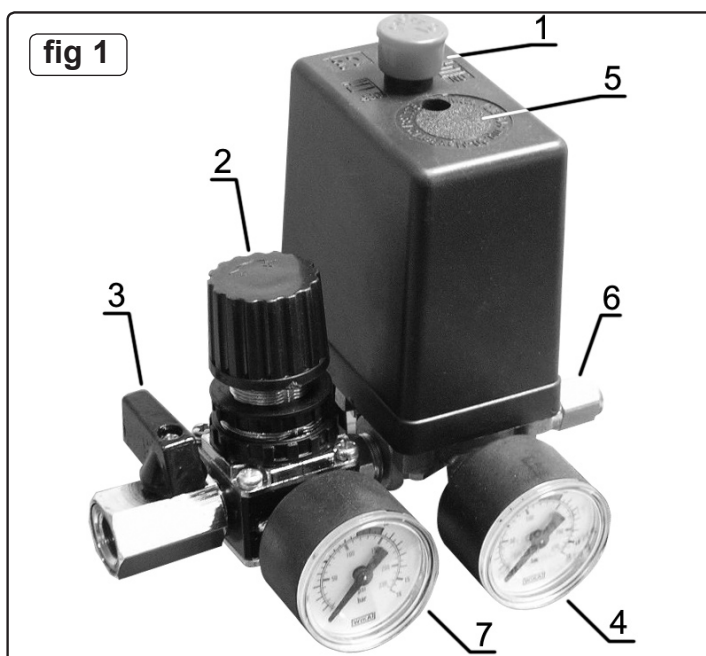

5. MAINTENANCE

In order to keep the compressor in good working condition, periodic maintenance is essential.

- ❑ **WARNING! service and maintenance must be performed by an authorised agent. DO NOT tamper with, or attempt to adjust, pressure switch or safety valve. Before moving, or carrying out any maintenance on the compressor, ensure that it is unplugged from the mains power supply and that the air tank pressure has been vented.**

5.1 GENERAL WORKSHOP MAINTENANCE

At the end of each working day, drain any moisture from the main tank as described above in section 4.4.

WARNING! Wear safety goggles when performing this task.

NOTE: As the residue is oil-free it may be disposed of through the normal sewage system.

6. TROUBLESHOOTING

Fault	Cause	Remedy
Pressure drop in the tank.	Air leaks at connections.	Run compressor to max. pressure, switch off. Brush soap solution over connections and look for bubbles. Tighten connections showing leaks. If problem persists contact Authorised Service Agent.
Pressure switch valve leaks when compressor is idle.	Non-return valve seal defective.	Empty the air tank, remove the non-return valve and clean the valve (item 8).
Safety valve operates below max pressure	Faulty valve.	Contact Authorised Service Agent.
Motor works but no air produced.	Valves leaking or head gasket damaged.	Check for leaks, or Contact Authorised Service Agent.
Compressor stops and does not restart.	Electrical, motor or pressure switch failure.	Check electrical supply, or Contact Authorised Service Agent.
Compressor does not stop when max. pressure is reached, safety valve operates.	Pressure switch failure or incorrect setting.	Contact Authorised Service Agent.
Low air flow.	Air valve plate or air valve is damaged (parts of item 14). Diaphragm damaged (part of item 14). The head screws are loose (item 15).	Change the defective air valve plate or air valve. Change diaphragm. Tighten the screws equally.
Noisy operation	Air hose too tight. Air hose leaking. The head screws are too tight (item 15). Bearing fault.	Back off 1/4 turn. Check seals or renew hose. Loosen the screws and then tighten them equally, do not overtighten. Return to dealer for checking.
Humming noise but does not operate:	The head screws are too tight (item 15).	Loosen the screws and then tighten them equally, do not overtighten

NOTE: It is our policy to continually improve products and as such we reserve the right to alter data, specifications and component parts without prior notice.

IMPORTANT: No liability is accepted for incorrect use of this product.

WARRANTY: Guarantee is 12 months from purchase date, proof of which will be required for any claim.

INFORMATION: For a copy of our latest catalogue and promotions call us on 01284 757525 and leave your full name and address, including postcode.



Sole UK Distributor, Sealey Group,
Kempson Way, Suffolk Business Park,
Bury St. Edmunds, Suffolk,
IP32 7AR



01284 757500



www.sealey.co.uk



01284 703534



sales@sealey.co.uk