

Thank you for purchasing a Sealey product. Manufactured to a high standard this product will, if used according to these instructions and properly maintained, give you years of trouble free performance.

⚠ IMPORTANT: PLEASE READ THESE INSTRUCTIONS CAREFULLY. NOTE THE SAFE OPERATIONAL REQUIREMENTS, WARNINGS & CAUTIONS. USE THE PRODUCT CORRECTLY AND WITH CARE FOR THE PURPOSE FOR WHICH IT IS INTENDED. FAILURE TO DO SO MAY CAUSE DAMAGE AND/OR PERSONAL INJURY, AND WILL INVALIDATE THE WARRANTY. PLEASE KEEP INSTRUCTIONS SAFE FOR FUTURE USE.

1. SAFETY INSTRUCTIONS

- ✓ Familiarise yourself with the application and limitations of the air hose reel, as well as the specific hazards.
- ❗ **WARNING!** Disconnect the air hose reel from the air supply before changing accessories, servicing or performing any maintenance.
- ✓ Maintain the air hose reel in good condition (use an authorised service agent).
- ✓ Replace or repair damaged parts. *Use recommended parts only. Unauthorised parts may be dangerous and will invalidate the warranty.*
- ✓ Locate and fix the air hose reel in a suitable working area. Do not position the hose in direct sun light, or in areas of extreme heat or cold. Ensure there is adequate lighting.
- ❑ **WARNING!** Ensure maximum air pressure is not exceeded.
- ✓ Keep extended air hose away from heat, oil and sharp edges. Check hose for wear before each use, and ensure all connections are secure.
- ✓ Keep the unwound air hose at a safe distance from the working area and free from wet, damp, oily surfaces.
- ❑ **WARNING!** Always wear approved eye or face protection when operating the air hose reel.
- ✓ Maintain correct balance and footing. Ensure the floor is not slippery and wear non-slip shoes.
- ✓ Remove ill fitting clothing. Remove ties, watches, rings, and other loose jewellery and contain and/or tie back long hair.
- ✓ Keep children and unauthorised persons away from the working area.
- ✗ **DO NOT** operate the air hose reel if any parts are damaged or missing as this may cause failure and/or personal injury.
- ✗ **DO NOT** exceed the rated capacity of the air hose reel.
- ✗ **DO NOT** use the air hose reel for any purpose other than that for which it is designed.
- ✗ **DO NOT** operate the air hose reel when you are tired, under the influence of alcohol, drugs or intoxicating medication.
- ✗ **DO NOT** direct air from the air hose at yourself or others.
- ✓ When not in use ensure the air supply is turned off and tools disconnected. Disconnect from the air supply and retract the hose into case.
- ❑ **WARNING! DO NOT** dismantle the hose reel casing, or attempt to remove the screws and covers on the sides. *To do so may result in damage to the appliance and/or personal injury and will invalidate the warranty. Internal maintenance, which will require the opening of the casing, must only be undertaken by an authorised service agent.*

2. INTRODUCTION & SPECIFICATION

The SA88.V3 has a hard wearing composite casing with retracting air hose reel. Free-running operation enabling easy access to locations within the extended air hose range. The reel comes complete with an attachment bracket for wall or ceiling mounting.

MODEL NO.	SA88.V3	Maximum pressure290psi
Hose length20m	Hose type	PVC
Hose bore10mm	Inlet - Outlet Ø3/8" - 1/4" BSP

3. INSTALLATION

❑ **WARNING! Ensure the hose is disconnected from the air supply. Do not position the hose in direct sun light or in areas of extreme heat or cold.**

- 3.1 Attach the carrying handle to the reel casing just above the hose mouth using the two self tapping screws provided,
- 3.2 **Mounting the reel.**
- 3.3 Due to the way the retractable hose operates the reel should only be mounted in one of the four positions shown below. The standard bracket supplied (BU100) will enable you to mount in positions 1 & 2. If wish to mount in positions 3 or 4 you will need to purchase the optional bracket (BB100).
Do not mount the reel more than 4.8M above the ground. The maximum weight of any air tool attached to the end of the hose should not exceed 2kg.
- 3.4 Ensure the wall, ceiling or other structure, to which the air hose is to be fixed is of sound construction and that the securing point will hold the working strain of the hose when in use.

1. WALL MOUNT (BU100)
(Up to 1.8m above ground.)

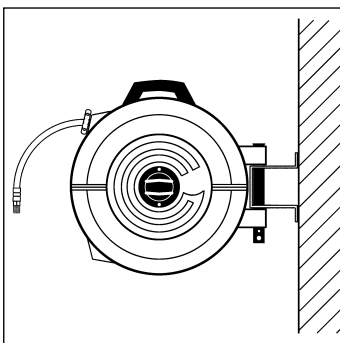

2. OVERHEAD MOUNT (BU100)
(Up to 4.5m above ground.)

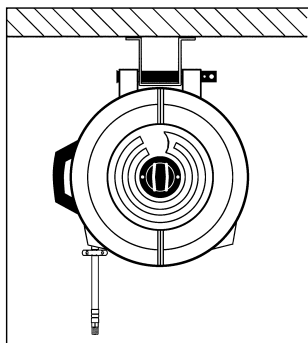

3. FLOOR / BENCH MOUNT (BB100)

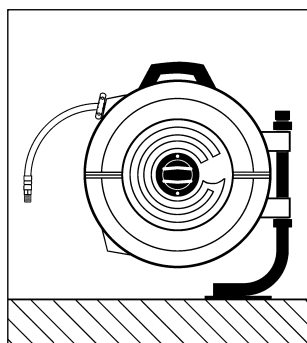

4. HIGH WALL MOUNT (BB100)
(Between heights 1.8 to 4.5M)

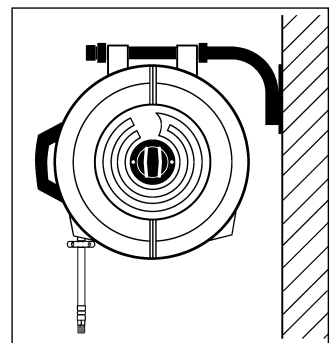

- 3.5 Screw fix the bracket to the chosen surface using fixings that are appropriate to the substrate and strong enough to carry the weight of the reel plus the working strain exerted on it when in use. When fixing to a vertical surface ensure that the bracket is vertically aligned.
- 3.6 Align the tubular bracket mountings on the reel with the holes in the mounting bracket and slide the swivel tube through both items to fix the reel to the bracket. Ensure that the retaining flange on the tube is at the top of the bracket when the reel is mounted vertically. The swivel tube for the standard bracket is pierced at one end so that a padlock can be attached to it for security purposes.
- 3.7 Connect the air supply to the reel using a flexible hose sufficiently long to allow the reel to swivel 180° from side to side.
- 3.8 When the reel is positioned overhead the swivelling action can be locked by the use of the 'steady' bracket provided (as shown in fig.5-A). The steady bracket is positioned between the main casing and the mounting bracket and is held in position when the swivel tube is inserted. The steady bracket is not recommended for wall mounting.

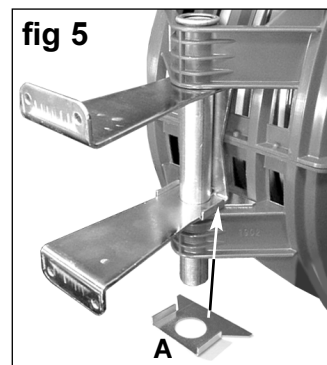

4. OPERATION.

- 4.1 Pull out the hose to the required length.

NOTE: A clicking noise can be heard every half revolution of the drum.

- 4.2 To latch the reel, allow the reel to slowly retract after hearing the 1st, 2nd or 3rd click.
- 4.3 To unlatch the reel, slowly pull out the hose until the clicking noise stops, then let the hose slowly retract until the hose stopper rests against the reel mouth.

⚠ WARNING! To prevent injury or damage occurring, do not let go of the hose during rewinding.

5. MAINTENANCE & STORAGE

⚠ WARNING! Before carrying out routine maintenance or inspection, vent any pressure remaining in the hose.

- 5.1 The hose reel does not require special maintenance as it is lubricated for life. To ensure reliable operation, clean the hose and casing regularly. **DO NOT** spray or wet the product, but clean with a cloth and warm water. **DO NOT** use solvents or detergents, as these may permanently damage the plastic.
 - 5.2 There are no user serviceable parts. All maintenance and repairs which require the case to be opened or dismantled should be carried out by an authorised service agent only.
- ⚠ WARNING! DO NOT** dismantle the hose reel casing, or attempt to remove the screws and covers on the sides. To do so may result in damage to the appliance and/or personal injury and will invalidate the warranty.

STORAGE:

Should you wish to store the air hose, ensure it is clean and dry. Place the item in a dark, safe, dry, childproof location, where the temperature will remain reasonably stable. **DO NOT** store in a nylon, or plastic, bag as this will encourage condensation.

6. TROUBLESHOOTING.

PROBLEM	POSSIBLE CAUSE	SOLUTION
Hose will not retract.	Hose bunching within reel. Spring tension too tight. Replacement hose too heavy.	Pull hose out of reel and guide back in. Have spring tension adjusted by authorised service agent. Have correct hose fitted by authorised service agent.
Reel will not latch.	The hose has been pulled past the latching teeth. Broken latching pawl or pawl spring.	Allow reel to retract slowly after hearing 1st, 2nd or 3rd click. Have new latching pawl or pawl spring fitted by authorised service agent.
Reel leaks.	Damaged hose. Loose air connection. Worn swivel seals.	Have new hose fitted by authorised service agent. Tighten fitting. Have new seals fitted by authorised service agent.

NOTE: It is our policy to continually improve products and as such we reserve the right to alter data, specifications and component parts without prior notice.

IMPORTANT: No liability is accepted for incorrect use of this equipment.

WARRANTY: Guarantee is 12 months from purchase date, proof of which will be required for any claim.

INFORMATION: For a copy of our latest catalogue and promotions call us on 01284 757525 and leave your full name and address, including postcode.

	Sole UK Distributor Sealey Group, Bury St. Edmunds, Suffolk.	01284 757500	www.sealey.co.uk sales@sealey.co.uk
		01284 703534	