

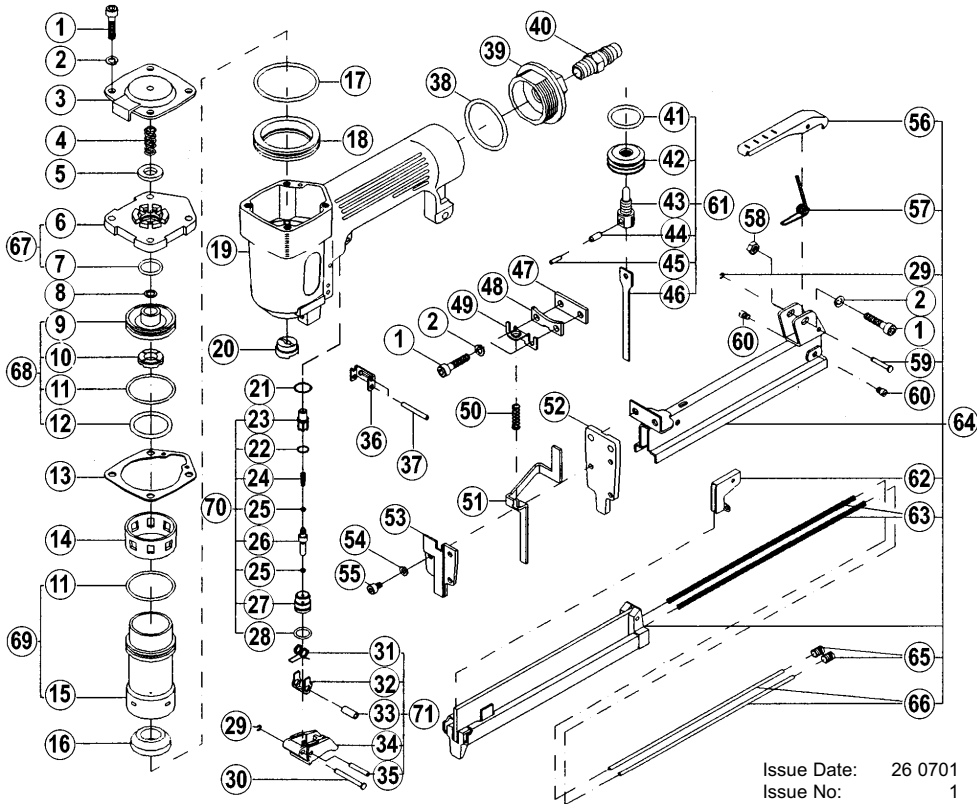

INSTRUCTIONS FOR
AIR OPERATED STAPLER
 Model: **SA79R**

Thank you for purchasing a Sealey Product. Manufactured to a high standard this product will, if used according to these instructions and properly maintained, give you years of trouble free performance.

IMPORTANT: PLEASE READ THESE INSTRUCTIONS CAREFULLY. NOTE THE SAFE OPERATIONAL REQUIREMENTS, WARNINGS AND CAUTIONS. USE THIS PRODUCT CORRECTLY AND WITH CARE FOR THE PURPOSE FOR WHICH IT IS INTENDED. FAILURE TO DO SO MAY CAUSE DAMAGE OR PERSONAL INJURY AND WILL INVALIDATE THE WARRANTY. PLEASE KEEP INSTRUCTIONS SAFE FOR FUTURE USE.



Issue Date: 26 0701
 Issue No: 1
 Date Modified: N/A

ITEM	PART NO.	DESCRIPTION	ITEM	PART NO.	DESCRIPTION	ITEM	PART NO.	DESCRIPTION
1	SA79R/01	SCREW 5*22	25	SA79R/25	O-RING 1.9*1.2	49	SA79R/49	SPRING HOLDER
2	SA79R/02	WASHER #5*1.1t	26	SA79R/26	REMOTE CORE	50	SA79R/50	COMPRESSION SPRING
3	SA79R/03	EXHAUST COVER	27	SA79R/27	REMOTE HOUSING	51	SA79R/51	RELEASE CATCH
4	SA79R/04	COMPRESSION SPRING	28	SA79R/28	O-RING 9.8*1.9	52	SA79R/52	DRIVER GUIDE
5	SA79R/05	SEAL AIR	29	SA79R/29	E-RING 2.5 DIAM	53	SA79R/53	DRIVER GUIDE COVER
6	SA79R/06	CYLINDER CAP	30	SA79R/30	STEP PIN DIAM 2.9*29	54	SA79R/54	WASHER #4*1.2t
7	SA79R/07	O-RING 13.8*2.4	31	SA79R/31	EXTENSION SPRING	55	SA79R/55	SCREW 4*5.5
8	SA79R/08	WASHER 9*6*0.8	32	SA79R/32	TRIGGER GUIDE	56	SA79R/56	CLICK LEVER.
9	SA79R/09	HEAD VALVE PISTON	33	SA79R/33	PIN BUSHING	57	SA79R/57	TORSION SPRING
10	SA79R/10	PISTON STOPPER	34	SA79R/34	TRIGGER	58	SA79R/58	HEX. NUT M5
11	SA79R/11	O-RING 31*2.5	35	SA79R/35	PIN 3*18.8	59	SA79R/59	STEP PIN DIAM 5*18.6
12	SA79R/12	O-RING 25*3.5	36	SA79R/36	CATCH GUIDE PLATE	60	SA79R/60	SCREW M4
13	SA79R/13	GASKET	37	SA79R/37	SPRING PIN 3*26	61	SA79R/61	PISTON SET
14	SA79R/14	COLLAR	38	SA79R/38	O-RING 35*3.5	62	SA79R/62	PUSHER
15	SA79R/15	CYLINDER	39	SA79R/39	TAIL COVER	63	SA79R/63	FEEDER SPRING
16	SA79R/16	BUMPER	40	SA79R/40	AIR PLUG	64	SA79R/64	MAGAZINE SET
17	SA79R/17	O-RING 39.4*3.1	41	SA79R/41	O-RING 21.3*3	65	SA79R/65	SCREW M6
18	SA79R/18	SPACER	42	SA79R/42	PISTON HEAD	66	SA79R/66	STEEL BAR
19	SA79R/19	BODY	43	SA79R/43	DRIVER BLADE PIN	67	SA79R/67	CYLINDER CAP SET
20	SA79R/20	NOZZLE	44	SA79R/44	OUTER SPRING PIN 4*10	68	SA79R/68	HEAD VALVE PISTON SET
21	SA79R/21	O-RING 11*1.05	45	SA79R/45	INNER SPRING PIN 2.5*10	69	SA79R/69	CYLINDER SET
22	SA79R/22	O-RING 8*1	46	SA79R/46	DRIVER BLADE	70	SA79R/70	TRIGGER VALVE SET
23	SA79R/23	UPPER REMOTE HOUSING	47	SA79R/47	SPACER	71	SA79R/71	TRIGGER SET
24	SA79R/24	CONICAL SPRING	48	SA79R/48	SPACER			

1. SAFETY INSTRUCTIONS

- p **WARNING!** Ensure Health & Safety, local authority, and general workshop practice regulations are adhered to when using this equipment.
- p **WARNING!** Disconnect from air supply before refilling with staples, servicing or performing maintenance.
- 3 Maintain the stapler in good condition (use an authorised service agent).
- 3 Replace or repair damaged parts. Use genuine parts only. Non-authorized parts may be dangerous and will invalidate the warranty.
- 3 Use in suitable clean and tidy work area, free from unrelated materials and ensure there is adequate lighting.
- p **WARNING!** Always wear approved eye and/or face and hand protection when operating the stapler.
- 3 Remove ill fitting clothing. Remove ties, loose jewellery, and contain and/or tie back long hair.
- 3 Wear appropriate protective clothing and keep hands and body clear of working parts.
- 3 Maintain correct balance and footing. Ensure the floor is not slippery and wear non-slip shoes.
- 3 Keep children and unauthorised persons away from the working area.
- 3 Check moving parts alignment on a regular basis.
- 3 Ensure workpiece is secure before operating the stapler. Never hold a workpiece by hand.
- 3 When the stapler is put down during pauses in operation ensure that the trigger catch slide is not depressed by the weight of the stapler or by placing the stapler in a restricted position that could put pressure on the trigger catch slide.
- 3 During extended breaks in operation disconnect the stapler from the air supply.
- p **WARNING!** Ensure correct air pressure is maintained and not exceeded. Recommended pressure 50-90psi.
- 3 Keep air hose away from heat, oil and sharp edges. Check air hose for wear before each use and ensure that all connections are secure.
- 3 Prolonged exposure to vibration from this stapler may pose a health risk. It is the operator's responsibility to correctly assess the potential hazard and issue guidelines for safe periods of use and offer suitable protective equipment.
- 7 DO NOT point the staple discharge outlet at yourself or anyone else. Do not point at animals.
- 7 DO NOT use any power source except an air compressor.
- 7 DO NOT operate the stapler near any inflammable substance or on any container that once contained an inflammable substance.
- 7 DO NOT use the stapler for a task it is not designed to perform.
- 7 DO NOT operate stapler if any parts are damaged or missing as this may cause failure and/or personal injury.
- 7 DO NOT carry the stapler by the hose, or yank the hose from the air supply.
- 7 DO NOT place the stapler close to your face and do not point at other persons or animals.
- 7 DO NOT operate stapler when you are tired, under the influence of alcohol, drugs or intoxicating medication.
- 7 DO NOT carry the stapler with your finger on the trigger.
- 7 DO NOT direct air from the air hose at yourself or others.
- 3 When not in use, disconnect from air supply and store in a safe, dry, childproof location.

SEALEY POWER PRODUCTS Sole UK Distributor, Sealey Group, Bury St. Edmunds, Suffolk.
 ☎ 01284 757500 🖨 01284 703534 ✉ email: sales@sealey.co.uk

NOTE: It is our policy to continually improve products and as such we reserve the right to alter data, specifications and component parts without prior notice. **IMPORTANT:** No liability is accepted for incorrect use of this equipment. **WARRANTY:** Guarantee is 12 months from purchase date, proof of which will be required for any claim. **INFORMATION:** Call us for a copy of our latest catalogue and promotions on 01284 757525 and leave your full name and address including your postcode.

2. INTRODUCTION & SPECIFICATION

The SA79R is a light weight well balanced stapler suitable for stapling a wide variety of materials including woods, plastics and fabrics. It has a rubber comfort grip and trigger safety catch. The kit supplied includes a starter pack of staples, goggles, a tape measure, hex keys and air tool oil. A carrying case is supplied.

SPECIFICATION

Capacity	Staples available in packs of 5000 (20 gauge).	Part No.	Crown.	Length
.16 & 25mm 20 gauge staples		SA-AS/16	5.0	16mm
Operating Pressure	.50 - 90psi	SA-AS/25	5.0	25mm
Air Consumption	.6cfm			
Air Inlet	1/4" BSP			
Weight	.08kg			

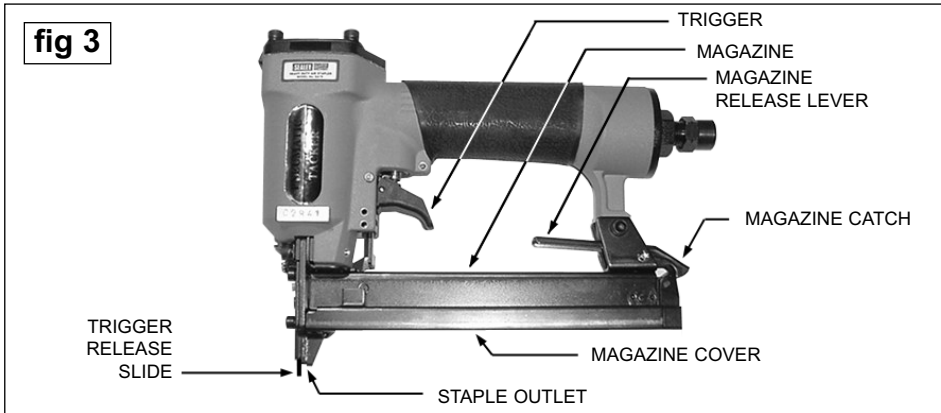

3. PREPARING STAPLER FOR USE

3.1. Air Supply

- 3.1.1. Before connecting to an air supply ensure that the trigger catch release slide is not depressed. (see fig.3)
- 3.1.2. You will require an air pressure between 50-90psi, and an air flow according to the specification above.
- 3.1.3. **WARNING!** Ensure the air supply is clean and does not exceed 90 psi while operating the stapler. Too high an air pressure and unclean air will shorten the product life due to excessive wear, and may be dangerous causing damage and/or personal injury.
- 3.1.4. Drain the air tank daily. Water in the air line will damage the stapler **and will invalidate your warranty.**
- 3.1.5. Clean air inlet filter weekly. Recommended hook-up procedure is shown in fig 1.
- 3.1.6. Line pressure should be increased to compensate for unusually long air hoses (over 8 metres). The minimum hose diameter should be 1/4" I.D. and fittings must have the same inside dimensions.
- 3.1.7. Keep hose away from heat, oil and sharp edges. Check hoses for wear, and make certain that all connections are secure.

3.2. Couplings.

Vibration may cause failure if a quick change coupling is connected directly to the air stapler. To overcome this, connect a leader hose to the stapler. A quick change coupling may then be used to connect the leader hose to the air line recoil hose. See fig 1 & 2.

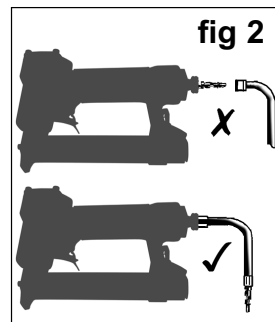
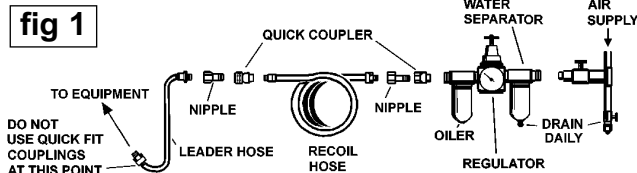

4. OPERATING INSTRUCTIONS

- WARNING! Ensure you read, understand and apply safety instructions before use.**
- 4.1 Load the magazine with staples before connecting the airline. To open the magazine hold the stapler vertically with one hand and using your other thumb, press the lever catch which will allow the magazine to slide open. Place a batch of staples into the open magazine chamber with the staple legs facing outwards.
 - 4.2 Slide the magazine cover shut until it clicks into place behind the catch. As you do this the internal spring will start to bear onto the batch of staples holding them in place ready for stapling.
 - 4.3 Before connecting to an air supply ensure that the trigger catch release slide is not depressed. Connect the air line to the stapler as described in Section 3.
 - 4.4 The operating trigger is normally locked and cannot be used until the trigger release slide is depressed. This happens automatically as you position the stapler.
 - 4.5 The trigger release slide can be seen protruding downwards just in front of the staple outlet. (see fig.3) Place the tip of the slide onto the material to be stapled and press downwards to bring the staple outlet into contact with the surface. As the slide retracts the trigger will become free.
 - 4.6 Depress the trigger to fire one staple. To fire another staple release the trigger, reposition the stapler at the next required stapling point and depress the trigger again. Repeat as necessary.
 - 4.7 If you need to put the stapler down during the course of working ensure that the trigger slide catch is not depressed against any object.
 - 4.8 When the work is complete or when you have paused for any length of time, disconnect the stapler from the air line.

5. MAINTENANCE

- WARNING!** Disconnect stapler from air supply before refilling with staples, servicing or performing maintenance. Replace or repair damaged parts.
Use genuine parts only. Non-authorized parts may be dangerous and will invalidate the warranty.
- 5.1. Lubricate the air stapler daily with a few drops of the air tool oil supplied, dripped into the air inlet before use. (To re-order air tool oil use Sealey part Nos. ATO/500 or ATO/1000.)
 - 5.2. Clean the stapler after use.
 - 5.3. Loss of power or erratic action may be due to the following:
 - a) Excessive drain on the air line. Moisture or restriction in the air pipe. Incorrect size or type of hose connectors. To remedy check the air supply and follow instructions in chapter 3.
 - b) Grit or gum deposits in the stapler may also reduce performance. If your model has an air strainer (located in the area of the air inlet), remove the strainer and clean it. Flush the stapler out with gum solvent oil or an equal mixture of SAE No 10 oil and kerosene. Allow to dry before use. If you continue to experience problems, contact your local Sealey service agent.
 - 5.4. For a full service contact your local Sealey service agent.
 - 5.5. When not in use, disconnect from air supply, clean stapler and store in a safe, dry, childproof location.
 - 5.6. On a weekly basis check the security of the hex bolts holding the driver guide plate in place and tighten if necessary. (see fig.3)

Declaration of Conformity

CE We, the sole importer into the UK, declare that the product listed here is in conformity with the following EEC standards and directives. The construction file for this product is held by the Manufacturer and may be inspected, by a national authority, upon request to Jack Sealey Ltd.

**Air Operated Stapler
Model: SA79R**

98/37/EC Machinery Directive
93/68/EEC Marking Directive

Signed by Mark Sweetman

26th July 2001

For Jack Sealey Ltd. Sole importer into the UK of Sealey Power Products.