

PARTS LIST FOR:

180mm VERTICAL AIR POLISHER MODEL: SA703

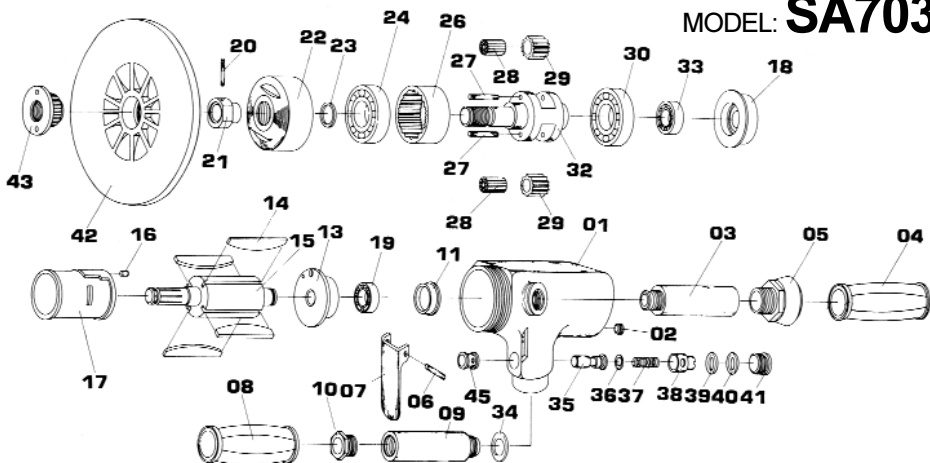

ITEM	PART NO.	DESCRIPTION	ITEM	PART NO.	DESCRIPTION
01.	SA703/01	MOTOR HOUSING	24.	SA703/24	BALL BEARING
02.	SA703/02	SET SCREW	26.	SA703/26	INTERNAL GEAR
03.	SA703/03	EXHAUST HANDLE	27.	SA703/27	NEEDLE ROLLER
04.	SA703/04	HANDLE GRIP (EXHAUST)	28.	SA703/28	NEEDLE ROLLER
05.	SA703/05	EXHAUST DEFLECTOR	29.	SA703/29	PLANET GEAR
06.	SA703/06	SPRING PIN	30.	SA703/30	BALL BEARING
07.	SA703/07	THROTTLE LEVER	32.	SA703/32	PLANET CAGE
08.	SA703/08	HANDLE GRIP (INLET)	33.	SA703/33	BALL BEARING
09.	SA703/09	INLET HANDLE	34.	SA703/34	O-RING
10.	SA703/10	AIR INLET BUSHING	35.	SA703/35	VALVE STEM
11.	SA703/11	BEARING CAP	36.	SA703/36	O-RING
13.	SA703/13	REAR END PLATE	37.	SA703/37	VALVE SPRING
14.	SA703/14	ROTOR BLADE	38.	SA703/38	AIR REGULATOR
15.	SA703/15	ROTOR	39.	SA703/39	O-RING
16.	SA703/16	SPRING PIN	40.	SA703/40	O-RING
17.	SA703/17	CYLINDER	41.	SA703/41	VALVE SCREW
18.	SA703/18	FRONT END PLATE	42.	SA703/42	PAD
19.	SA703/19	BALL BEARING	43.	SA703/43	PAD NUT
20.	SA703/20	SPRING PIN	45.	SA703/45	BUSHING
21.	SA703/21	COLLAR	47.	SA703/47	WRENCH
22.	SA703/22	CLAMP NUT	48.	SA703/48	WRENCH
23.	SA703/23	OIL SEAL (V-MODEL)			

NOTE: It is our policy to continually improve products and as such we reserve the right to alter data, specifications and component parts without prior notice. **IMPORTANT:** No liability is accepted for incorrect use of this equipment. **WARRANTY:** Guarantee is 12 months from purchase date, proof of which will be required for any claim.

SEALEY

**POWER
TOOLS**

INSTRUCTIONS FOR :

180mm VERTICAL AIR POLISHER

MODEL: **SA703**

Thank you for purchasing a Sealey Product. Manufactured to a high standard this product will, if used according to these instructions and properly maintained, give you years of trouble free performance.

! **IMPORTANT:** PLEASE READ THESE INSTRUCTIONS CAREFULLY. NOTE THE SAFE OPERATIONAL REQUIREMENTS, WARNINGS AND CAUTIONS. USE THIS PRODUCT CORRECTLY AND WITH CARE FOR THE PURPOSE FOR WHICH IT IS INTENDED. FAILURE TO DO SO MAY CAUSE DAMAGE AND/OR PERSONAL INJURY AND WILL INVALIDATE THE WARRANTY. PLEASE KEEP INSTRUCTIONS SAFE FOR FUTURE USE.

1. SAFETY INSTRUCTIONS

- WARNING!** Ensure Health & Safety, local authority, and general workshop practice regulations are adhered to when using this equipment.
- WARNING!** Disconnect from air supply before changing accessories or servicing.
- ✓ Maintain the polisher in good condition (use an authorised service agent).
- ✓ Replace or repair damaged parts. Use genuine parts only. Unauthorised parts may be dangerous and will invalidate the warranty.
- ✓ Use in a suitable, clean and tidy work area, free from unrelated materials. Ensure that there is adequate lighting.
- ✓ Before each use check pad for condition. If worn or damaged replace immediately.
- WARNING!** Always wear approved eye or face and hand protection when operating the polisher.
- ✓ Use face, dust, or respiratory protection in accordance with COSHH regulations.
- ✓ Noise level may exceed 85dB - wear safety ear defenders.
- ✓ Remove ill fitting clothing. Remove ties, watches, rings, other loose jewellery and contain and/or tie back long hair.
- ✓ Wear appropriate protective clothing and keep hands and body clear of pad.
- ✓ Maintain correct balance and footing. Ensure that the floor is not slippery and wear non-slip shoes.
- ✓ Keep children and unauthorised persons away from the work area.
- ✓ Ensure workpiece is secure before operating the polisher. Never hold a workpiece by hand.
- ✓ Avoid unintentional starting.
- WARNING!** Ensure that correct air pressure is maintained and not exceeded. Recommended pressure is 90psi.
- ✓ Keep air hose away from heat, oil and sharp edges.
- ✓ Check air hose for wear before each use and ensure that all connections are secure.
- ✓ Prolonged exposure to vibration from this polisher poses a health risk. It is the owner's responsibility to correctly assess the potential hazard and issue guidelines for safe periods of use and offer suitable protective equipment.
- x DO NOT use an attachment which has a speed rating less than the speed rating of the polisher.
- x DO NOT use the polisher for a task it is not designed to perform.
- x DO NOT operate polisher if any parts are damaged or missing as this may cause failure and/or personal injury.
- x DO NOT carry the polisher by the hose, or yank the hose from the air supply.
- x DO NOT force, or apply heavy pressure to the polisher, let the polisher do the work.
- x DO NOT place attachments close to your face and do not point at other persons or animals.
- x DO NOT operate polisher when you are tired or under the influence of alcohol, drugs or intoxicating medication.
- x DO NOT carry the polisher with your finger on the power lever.
- x DO NOT direct air from the air hose at yourself or others.
- ✓ When not in use, disconnect from the air supply and store in a safe, dry, childproof location.

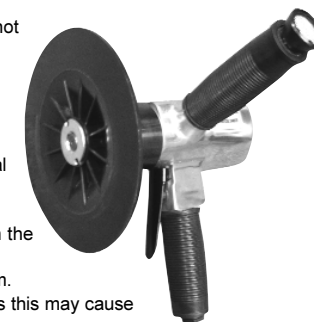

**SEALEY POWER
TOOLS**

Sole UK Distributor, Sealey Group, Bury St. Edmunds, Suffolk.

01284 757500

01284 703534

E-mail: sales@sealey.co.uk
Web: www.sealey.co.uk

Risk of Hand Arm Vibration Injury

10mm Reversible Air Drill model no. SA703 when operated in accordance with these instructions and tested in accordance with EN 28662-2: 1994 results in the following vibration emission declared in accordance with BS EN12096: 1996.

Measured vibration emission value: 2.5m/s²

Uncertainty: 1m/s²

These values are suitable for comparison with emission levels of other tools that have been subject to the same test.

This tool may cause hand-arm vibration syndrome if its use is inadequately managed.

Recommended Measures to reduce risk of hand-arm vibration syndrome:

This item represents a low Hand Arm Vibration risk to users. The calculated minimum usage period exceeds 8 hours. We recommend appropriate safety equipment is utilised and regular breaks for the operator are employed to reduce any residual risk of fatigue or repetitive strain injury.

2. INTRODUCTION & SPECIFICATION

Chrome polished housing complete with rubber grip handles. Unit comes with built in air regulator. Trigger operated throttle control. Exhaust outlet at end of side handle with muffler to reduce noise. Supplied with backing pad and spanners.

Pad Size	Ø180mm	Air Inlet	1/4" BSP
Thread Size5/8" UNC	Sound	90.5 dB.a
Free Speed Loaded/Unloaded2300rpm	Vibration	2.5m/s ²
Max. Operating Pressure90psi	Uncertainty Value1m/s ²
Air Consumption6cfm	Weight2kg

3. AIR SUPPLY

Recommended hook-up is shown in fig. 1.

1. Ensure that the polisher air valve (or throttle) is in the "off" position before connecting to the air supply.
2. You will require an air pressure between 70-90psi, and an air flow according to the specification above.
3. **WARNING!** Ensure that the air supply is clean and does not exceed 90psi while operating the polisher. Too high an air pressure and/or unclean air will result in excessive wear and may be dangerous, causing damage and/or personal injury.
4. Drain the compressor air tank daily. Water in the air line will damage the polisher and invalidate your warranty.
5. Clean compressor air inlet filter weekly.
6. Line pressure should be increased to compensate for unusually long air hoses (over 8 metres). The minimum hose diameter should be 1/4" I.D. and fittings must have the same inside dimensions.
7. Keep hoses away from heat, oil and sharp edges. Check hoses for wear, and make certain that all connections are secure.
8. Vibration may cause failure if a quick change coupling is connected directly to the air polisher. To overcome this, connect a leader hose to the polisher. A quick change coupling may then be used to connect the leader hose to the air line recoil hose. See figs. 1 & 2.

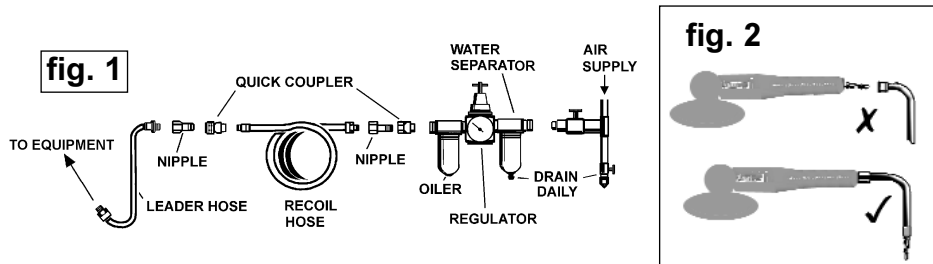

4. OPERATING INSTRUCTIONS

WARNING! Ensure that you read, understand and apply the safety instructions before use.

4.1. Assembly

- 4.1.1. Your SA703 comes with two handles, two spanners, a securing nut and a backing disc.
- 4.1.2. The detachable handle is screwed into the left-hand side of the head.
- 4.1.3. Screw the disc onto the spindle using the larger-mouthed spanner to steady the spindle and secure with the locking nut, using the second spanner with the locating pegs to tighten.
- 4.1.4. Fix appropriate polishing pad to the backing disc. Use only pads with speed ratings equal to, or higher than, the speed rating of the polisher.
- 4.1.5. Connect air supply to polisher and press the control valve lever to check that the polisher is working correctly.

4.2. Operating

Always use a polishing pad appropriate for the job. Work progressively from coarse to finer grades. DO NOT go from coarse to fine in one step as it may be difficult to remove swirl marks left by the coarse pad. DO NOT apply excessive pressure, let the polisher do the work for you. Start the polisher and bring the pad to the work surface evenly and slowly. Move the polisher back and forth in overlapping areas. Remove the pad from the work surface before stopping the polisher. Regularly check the pad for wear, always change a damaged pad. DO NOT allow the polisher to run in "idle rotation" for an extended period of time as this will reduce bearing life.

5. MAINTENANCE

WARNING! Disconnect the polisher from air supply before changing accessories, servicing or performing maintenance. Replace or repair damaged parts. *Use genuine parts only. Unauthorised parts may be dangerous and will invalidate the warranty.*

- 5.1. If the air supply system does not include an oiler, lubricate the air polisher daily with a few drops of good grade air tool oil such as Sealey ATO/500 or ATO1000, dripped into the air inlet before use.
- 5.2. Clean the polisher after use and change pads when required.
- 5.3. Loss of power or erratic action may be due to the following:
 - a) Excessive drain on the air line. Moisture or restriction in the air pipe. Incorrect size or type of hose connectors. To remedy check the air supply and follow instructions in Section 3.
 - b) Grit or gum deposits in the polisher may also reduce performance. If your model has an air strainer (located in the area of the air inlet), remove the strainer and clean it. Flush out the polisher with gum solvent oil or an equal mixture of SAE No 10 oil and kerosene. Allow to dry before use.
If you continue to experience problems, contact your local Sealey service agent.
- 5.4. When not in use, disconnect from air supply, clean and store in a safe, dry, childproof location.

6. DECLARATION OF CONFORMITY

Declaration of Conformity



We, the sole importer into the UK, declare that the product listed here is in conformity with the following standards and directives. The construction file for this product is held by the Manufacturer and may be inspected, by a national authority, upon request to Jack Sealey Ltd.

180mm Vertical Air Polisher
SA703
98/37/EC Machinery Directive
93/68/EEC Marking Directive

Signed by Mark Sweetman

21st October 2004

For Jack Sealey Ltd. Sole importer into the UK of Sealey Power Tools.



Sole UK Distributor
Sealey Group,
Bury St. Edmunds, Suffolk.

01284 757500
01284 703534

www.sealey.co.uk
sales@sealey.co.uk