



INSTRUCTIONS FOR:  
**AIR IMPACT WRENCH PISTOL  
 SUPER-DUTY LONG ANVIL**  
 MODEL No: **SA684**

Thank you for purchasing a Sealey Product. Manufactured to a high standard this product will, if used according to these instructions and properly maintained, give you years of trouble free performance.



**IMPORTANT: PLEASE READ THESE INSTRUCTIONS CAREFULLY. NOTE THE SAFE OPERATIONAL REQUIREMENTS, WARNINGS AND CAUTIONS. USE THIS PRODUCT CORRECTLY AND WITH CARE FOR THE PURPOSE FOR WHICH IT IS INTENDED. FAILURE TO DO SO MAY CAUSE DAMAGE AND/OR PERSONAL INJURY AND WILL INVALIDATE THE WARRANTY. PLEASE KEEP INSTRUCTIONS SAFE FOR FUTURE USE.**

## 1. SAFETY INSTRUCTIONS

- ✓ Follow all workshop safety rules, regulations, and conditions when using wrench.
- WARNING!** Disconnect from air supply before changing accessories or servicing.
- ✓ Maintain the wrench in good condition and replace any damaged or worn parts. *Use genuine parts only. Unauthorised parts may be dangerous and will invalidate the warranty.*
- WARNING!** Check correct air pressure is maintained and not exceeded. We recommend 90psi.
- ✓ Keep air hose away from heat, oil and sharp edges. Check air hose for wear before each use and ensure that all connections are secure.
- ✓ Only use impact sockets which are specifically designed for use with an impact wrench.
- ✓ Wear approved safety eye/face shield, ear defenders and hand protection.
- WARNING!** Due to the possible presence of asbestos dust from brake linings, when working around vehicle brake systems we recommend you wear suitable respiratory protection.
- ✓ Maintain correct balance and footing. Ensure the floor is not slippery and wear non-slip shoes.
- ✓ Keep children and non essential persons away from the working area.
- X DO NOT use the wrench for a task it is not designed to perform.
- WARNING! DO NOT** use wrench if damaged or thought to be faulty. (Contact Service Agent).
- X DO NOT use wrench unless you have been instructed in its use by a qualified person.
- X DO NOT carry the wrench by the air hose, or yank the hose from the air supply.
- X DO NOT operate wrench if you are tired or under the influence of alcohol, drugs or intoxicating medication.
- X DO NOT carry wrench with your hand on the power trigger in order to avoid unintentional starting.
- X DO NOT direct air from the air hose at yourself or others.
- ✓ When not in use disconnect from air supply and store in a safe, dry, childproof location.

## 2. INTRODUCTION & SPECIFICATION

Super-duty 1”Sq drive pistol grip air impact wrench suitable for commercial and agricultural vehicle use. Pin clutch mechanism gives high power-to-weight ratio. Fitted with long anvil for areas with restricted access.  
 Three-position torque control with reverse.  
 Supplied with side handle and spring balance hoop.

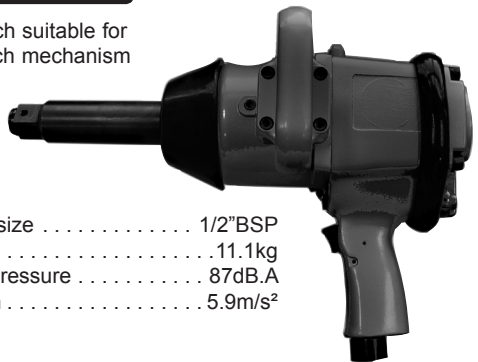

Drive size . . . . .	1”	Air inlet size . . . . .	1/2”BSP
Working/Max torque . .	1400/1600lb.ft	Weight . . . . .	.11.1kg
Ultimate torque . . . . .	1800lb.ft	Sound Pressure . . . . .	87dB.A
Speed . . . . .	3400rpm	Vibration . . . . .	5.9m/s <sup>2</sup>
Air consumption . . . . .	12cfm		
Operating pressure. . . . .	.90psi		

### 3. PREPARING WRENCH FOR USE

For recommended hook-up, procedure is shown in fig.1 & 2.

#### 3.1. Air Supply.

- 3.1.1. Ensure wrench air valve (or trigger) is in the "off" position before connecting to the air supply.
- 3.1.2. You will require an air pressure of 90psi and an air flow according to specification.
- 3.1.3.  **WARNING!** Ensure the air supply is clean and does not exceed 90psi while operating the wrench. Too high an air pressure and unclean air will shorten the product life due to excessive wear and may be dangerous causing damage and/or personal injury.
- 3.1.4. Drain the compressor air tank daily. Water in the air line will damage the wrench.
- 3.1.5. Clean compressor air inlet filter weekly.
- 3.1.6. Line pressure should be increased to compensate for unusually long air hoses (over 8 metres). The minimum hose diameter should be 1/2" I.D. and fittings must have the same inside dimensions.
- 3.1.7. Keep hose away from heat, oil and sharp edges. Check hose for wear and make certain that all connections are secure.

#### 3.2. Couplings.

Vibration may cause failure if a quick change coupling is connected directly to the wrench. To overcome this, connect a leader hose to the wrench. A quick change coupling may then be used to connect the leader hose to the air line recoil hose. See fig.1 & 2.

fig.1

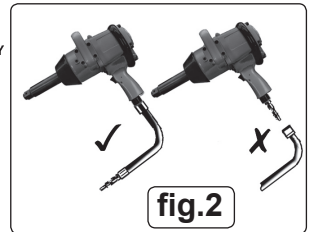
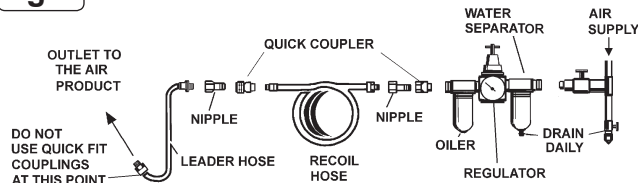

fig.2

### 4. OPERATING INSTRUCTIONS

- WARNING!** Ensure you read, understand and apply safety instructions before use.
- 4.1. Only use impact sockets which are specifically designed for use with an impact wrench.
  - 4.2. Connect the wrench to the air hose as in Section 3.
  - 4.3. Place the socket over the subject nut and depress the trigger to operate the wrench.
  - 4.4. To change drive direction turn the air regulator on the rear of the body to the desired direction. (fig.3)
  - 4.5. The torque may be adjusted in the forward gear by adjusting the torque control on the rear of the body, between 1 low power and 3 full power.

**DO NOT use any additional force upon the wrench in order to remove a nut.**

**DO NOT allow wrench to free run for an extended period of time as this will shorten its life.**

fig.3

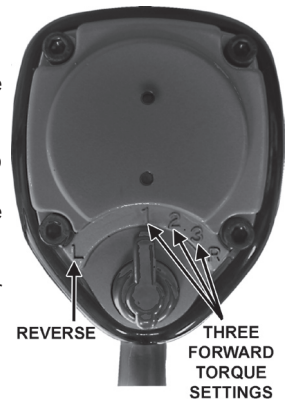

## 5. MAINTENANCE

- **WARNING!** Disconnect wrench from air supply before changing accessories, servicing or performing maintenance. Replace or repair damaged parts.  
*Use genuine parts only.*  
*Unauthorised parts may be dangerous and will invalidate the warranty.*
- 5.1. If the air system does not have an oiler, lubricate the air wrench daily with a few drops of Sealey air tool oil dripped into the air inlet.
- 5.2. Clean the wrench after use. **DO NOT use worn, or damaged sockets.**
- 5.3. Loss of power or erratic action may be due to the following:
  - a) Excessive drain on the air line. Moisture or restriction in the air pipe. Incorrect size or type of hose connectors. To remedy, check the air supply and follow instructions in Section 3.
  - b) Grit or gum deposits in the wrench may also reduce performance. Remove the strainer, clean it and flush the wrench out with gum solvent oil or an equal mixture of SAE No:10 oil and paraffin. Allow to dry before use.
- 5.4. For a full service contact your local Sealey service agent.
- 5.5. When not in use, disconnect from air supply, clean wrench and store in a safe, dry, childproof location.

### Risk of Hand Arm Vibration Injury

Impact Wrench, Model No. SA684 when operated in accordance with these instructions and tested in accordance with EN 28662-2: 1994 results in the following vibration emission declared in accordance with BS EN12096: 1996.

Measured vibration emission value: . . . . . 5.9m/s<sup>2</sup>

Uncertainty: . . . . . 2.36m/s<sup>2</sup>

**These values are suitable for comparison with emission levels of other tools that have been subject to the same test.**

**This tool may cause hand-arm vibration syndrome if its use is inadequately managed.**

**Recommended Measures to reduce risk of hand-arm vibration syndrome:**

This tool should not be used by an individual regularly for more than 2.9 hours in any 8 hour period.

This duration of use should be reduced if the individual is exposed to hand-arm vibration from other sources.

**NOTE:** It is our policy to continually improve products and as such we reserve the right to alter data, specifications and component parts without prior notice.

**IMPORTANT:** No liability is accepted for incorrect use of this product.

**WARRANTY:** Guarantee is 12 months from purchase date, proof of which will be required for any claim.

**INFORMATION:** For a copy of our latest catalogue and promotions call us on 01284 757525 and leave your full name and address, including postcode.



Sole UK Distributor, Sealey Group,  
Kempson Way, Suffolk Business Park,  
Bury St. Edmunds, Suffolk,  
IP32 7AR



01284 757500



www.sealey.co.uk



01284 703534



sales@sealey.co.uk