

Thank you for purchasing a Sealey product. Manufactured to a high standard this product will, if used according to these instructions and properly maintained, give you years of trouble free performance.



IMPORTANT: PLEASE READ THESE INSTRUCTIONS CAREFULLY. NOTE THE SAFE OPERATIONAL REQUIREMENTS, WARNINGS, AND CAUTIONS. USE THIS PRODUCT CORRECTLY, AND WITH CARE FOR THE PURPOSE FOR WHICH IT IS INTENDED. FAILURE TO DO SO MAY CAUSE DAMAGE AND/OR PERSONAL INJURY AND WILL INVALIDATE THE WARRANTY.

1. SAFETY INSTRUCTIONS

- WARNING!** *Ensure Health & Safety, local authority and general workshop practice regulations are adhered to when using this equipment.*
- WARNING!** Disconnect hammer from the air supply before changing accessories, servicing or performing any maintenance.
- ✓ Keep the hammer clean and maintain it in good condition (use an authorised service agent).
- ✓ Replace or repair damaged parts. *Use genuine parts only. Unauthorised parts may be dangerous and will invalidate the warranty.*
- ✓ Keep the work area clean and uncluttered. Ensure that there is adequate lighting.
- ✓ Ensure chisels are correctly rated for the job. **DO NOT** use damaged or suspect chisels.
- WARNING!** Wear approved safety eye or face protection, ear defenders and, if dust is generated, respiratory protection.
- ✓ Keep hands and body clear of the work when operating the hammer.
- ✓ Maintain correct balance and footing. Ensure that the floor is not slippery and wear non-slip shoes.
- ✓ Remove ill fitting clothing. Remove ties, watches, rings and other loose jewellery and contain and/or tie back long hair.
- ✓ Keep children and unauthorised persons away from the work area.
- ✓ Secure unstable workpiece with a clamp, vice or other adequate holding device.
- ✓ Avoid unintentional starting.
- WARNING!** Ensure that the correct air pressure is maintained and not exceeded.
- ✓ Keep air hose away from heat, oil and sharp edges. Check air hose for wear before use and ensure all connections are secure.
- ✗ **DO NOT** use the hammer for a task it is not designed to perform.
- ✗ **DO NOT** operate the hammer if any parts are damaged or missing as this may cause failure and/or personal injury.
- WARNING!** **DO NOT** chisel into any materials containing asbestos.
- ✗ **DO NOT** switch the hammer on whilst the chisel is in contact with the workpiece.
- ✗ **DO NOT** carry the by the hose, or yank the hose from the air supply.
- ✗ **DO NOT** hold the workpiece by hand. Use clamps or a vice to secure the workpiece. Available from your Sealey dealer.
- ✗ **DO NOT** allow untrained persons to operate the hammer.
- ✗ **DO NOT** operate the hammer when you are tired or under the influence of alcohol, drugs or intoxicating medication.
- ✗ **DO NOT** use hammer where there is flammable liquid, solid or gas such as paint solvent, including waste wiping or cleaning rags etc.
- ✗ **DO NOT** leave the hammer operating unattended.
- ✗ **DO NOT** carry the hammer with your finger on the trigger.
- ✗ **DO NOT** direct air from the air hose at yourself or others.
- ✓ When work is complete ensure that the air supply is turned off.
- ✓ When not in use disconnect from the air supply and store in a safe, dry, childproof area.

2. SPECIFICATIONS & INTRODUCTION

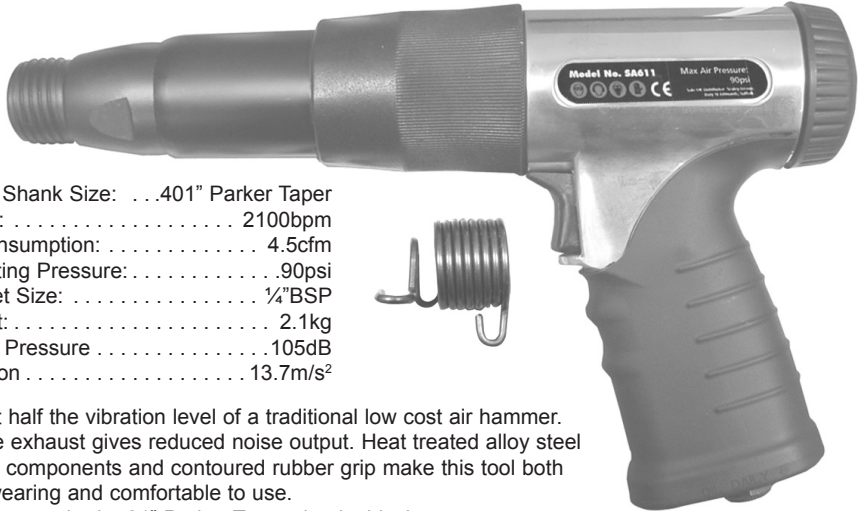

Chisel Shank Size:401" Parker Taper
 Speed: 2100bpm
 Air Consumption: 4.5cfm
 Operating Pressure:90psi
 Air Inlet Size: 1/4"BSP
 Weight: 2.1kg
 Sound Pressure105dB
 Vibration13.7m/s²

Almost half the vibration level of a traditional low cost air hammer. Handle exhaust gives reduced noise output. Heat treated alloy steel impact components and contoured rubber grip make this tool both hard-wearing and comfortable to use.

Accepts standard .401" Parker Taper shank chisels.

3. PREPARING HAMMER FOR USE

For recommended hook-up, procedure is shown in fig 1 & 2

3.1. Air Supply

- 3.1.1. Ensure hammer air valve (or trigger) is in the "off" position before connecting to the air supply.
- 3.1.2. You will require an air pressure of 90psi, and an air flow according to specification.
- 3.1.3. **WARNING!** Ensure the air supply is clean and does not exceed 90 psi while operating the hammer. Too high an air pressure and unclean air will shorten the product life due to excessive wear, and may be dangerous causing damage and/or personal injury.
- 3.1.4. Drain the air tank daily. Water in the air line will damage the hammer.
- 3.1.5. Clean air inlet filter weekly.
- 3.1.6. Line pressure should be increased to compensate for unusually long air hoses (over 8 metres). The minimum hose diameter should be 1/4" I.D. and fittings must have the same inside dimensions.
- 3.1.7. Keep hose away from heat, oil and sharp edges. Check hose for wear, and make certain that all connections are secure.

3.2. Couplings.

Vibration may cause failure if a quick change coupling is connected directly to the wrench. To overcome this, connect a leader hose to the wrench. A quick change coupling may then be used to connect the leader hose to the air line recoil hose. See fig 1 & 2.

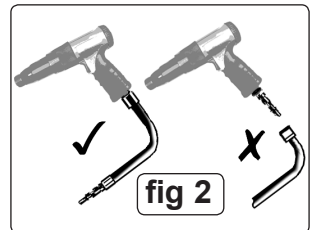
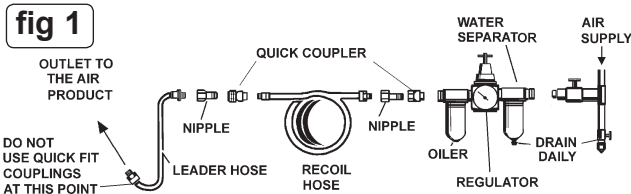

4. OPERATING INSTRUCTIONS

- 4.1 Insert the chisel shank into the gun cylinder (fig 3).
- 4.2 Place the retainer ring over the chisel (fig 3) and lower onto the hammer's cylinder thread. Wind the retainer spring on to the cylinder using a clockwise motion until the spring is fully located and the chisel is retained by the spring's retaining tag (fig 4).
- 4.3 To remove attachment reverse procedures 4.1 to 4.2.
- 4.4 Connect the tool to the air supply (see Section 3).
- 4.5 To operate the hammer, squeeze the trigger taking care that the chisel end is not in contact with the work-piece.

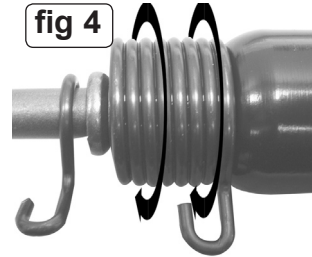
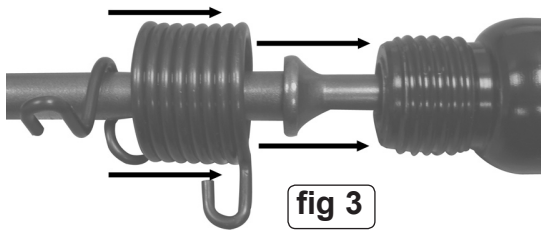

5. MAINTENANCE

- DO NOT allow hammer to free run for an extended period of time as this will shorten its life.
- ❑ **WARNING!** Disconnect hammer from air supply before changing accessories, servicing or performing maintenance. Replace or repair damaged parts. *Use genuine parts only. Unauthorised parts may be dangerous and will invalidate the warranty.*
- 5.1. If the air system does not have an oiler lubricate the air hammer daily with a few drops of Sealey air tool oil dripped into the air inlet.
 - 5.2. Clean the hammer after use. DO NOT use worn, or damaged chisels.
 - 5.3. Loss of power or erratic action may be due to the following:
 - a) Excessive drain on the air line. Moisture or restriction in the air pipe. Incorrect size or type of hose connectors. To remedy, check the air supply and follow instructions in Section 3.
 - b) Grit or gum deposits in the hammer may also reduce performance. Flush the hammer out with gum solvent oil or an equal mixture of SAE No 10 oil and paraffin. Allow to dry before use.
 - 5.4. For a full service contact your local Sealey service agent.
 - 5.5. When not in use, disconnect from air supply, clean hammer and store in a safe, dry, childproof location.

Risk of Hand Arm Vibration Injury

Air Hammer, model no. SA611 when operated in accordance with these instructions and tested in accordance with EN 28662-2: 1994 results in the following vibration emission declared in accordance with BS EN12096: 1996.

Measured vibration emission value: 13.7m/s²

Uncertainty: 5.48m/s²

These values are suitable for comparison with emission levels of other tools that have been subject to the same test. This tool may cause hand-arm vibration syndrome if its use is inadequately managed. Recommended Measures to reduce risk of hand-arm vibration syndrome:

This tool should not be used by an individual regularly for more than 32.6 minutes in any 8 hour period. This duration of use should be reduced if the individual is exposed to hand-arm vibration from other sources.

NOTE: It is our policy to continually improve products and as such we reserve the right to alter data, specifications and component parts without prior notice.

IMPORTANT: No liability is accepted for incorrect use of this product.

WARRANTY: Guarantee is 12 months from purchase date, proof of which will be required for any claim.

INFORMATION: For a copy of our latest catalogue and promotions call us on 01284 757525 and leave your full name and address, including postcode.



Sole UK Distributor, Sealey Group,
Kempson Way, Suffolk Business Park,
Bury St. Edmunds, Suffolk,
IP32 7AR

01284 757500

www.sealey.co.uk

01284 703534

sales@sealey.co.uk