

INSTRUCTIONS FOR
3/4" SQUARE DRIVE AIR IMPACT WRENCH
 Model: **SA59.V2**

Thank you for purchasing a Sealey Product. Manufactured to a high standard this product will, if used according to these instructions and properly maintained, give you years of trouble free performance.

IMPORTANT: PLEASE READ THESE INSTRUCTIONS CAREFULLY. NOTE THE SAFE OPERATIONAL REQUIREMENTS, WARNINGS AND CAUTIONS. USE THIS PRODUCT CORRECTLY AND WITH CARE FOR THE PURPOSE FOR WHICH IT IS INTENDED. FAILURE TO DO SO MAY CAUSE DAMAGE AND/OR PERSONAL INJURY AND WILL INVALIDATE THE WARRANTY. PLEASE KEEP INSTRUCTIONS SAFE FOR FUTURE USE.

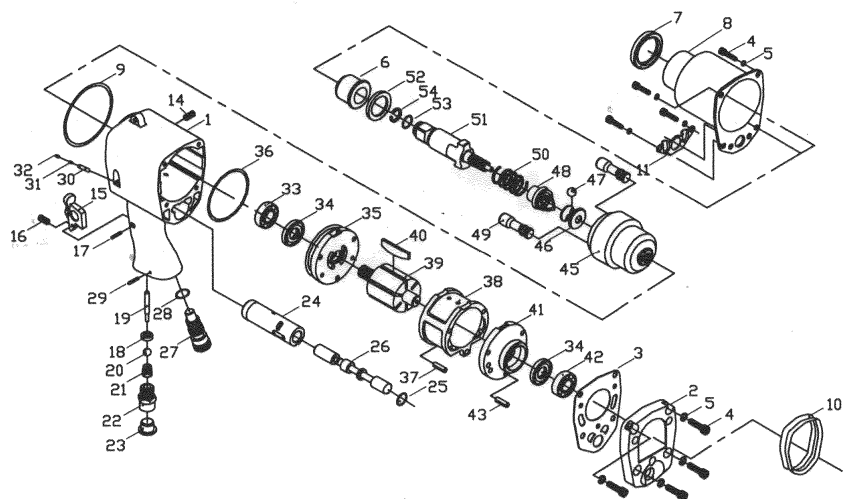

Issue : 1
 Date: 260602

Item	Part No	Description	Qty	Item	Part No	Description	Qty
1	SA59.V2.01	Motor Housing	1	29	SA59.V2.29	Spring Pin	1
2	SA59.V2.02	End Cap	1	30	SA59.V2.30	Pin	1
3	SA59.V2.03	End Cap Gasket	1	31	SA59.V2.31	Spring	1
4	SA59.V2.04	Screw	8	32	SA59.V2.32	Screw	1
5	SA59.V2.05	Spring Washer	8	33	SA59.V2.33	Bearing	1
6	SA59.V2.06	Anvil Bushing	1	34	SA59.V2.34	Oil Seal	2
7	SA59.V2.07	Oil Seal	1	35	SA59.V2.35	Frong End Plate	1
8	SA59.V2.08	Clutch Housing	1	36	SA59.V2.36	O-Ring	1
9	SA59.V2.09	O-Ring	1	37	SA59.V2.37	Spring Pin	1
10	SA59.V2.10	Protecting Rubber	1	38	SA59.V2.38	Cylinder	1
11	SA59.V2.11	Muffle Cover	1	39	SA59.V2.39	Rotor	1
14	SA59.V2.14	Oil Plug	1	40	SA59.V2.40	Rotor Blade	6
15	SA59.V2.15	Trigger	1	41	SA59.V2.41	Rear End Plate	1
16	SA59.V2.16	Screw	1	42	SA59.V2.42	Bearing	1
17	SA59.V2.17	Spring Pin	1	43	SA59.V2.43	Spring Pin	1
18	SA59.V2.18	Throttle Bushing	1	45	SA59.V2.45	Hammer Cage	1
19	SA59.V2.19	Throttle Pin	1	46	SA59.V2.46	Drive Cam Base	1
20	SA59.V2.20	Steel Ball	1	47	SA59.V2.47	Steel Ball	1
21	SA59.V2.21	Spring	1	48	SA59.V2.48	Drive Cam	1
22	SA59.V2.22	Hose Fitting	1	49	SA59.V2.49	Hammer Bar	2
23	SA59.V2.23	Dust Cover	1	50	SA59.V2.50	Spring	1
24	SA59.V2.24	Valve Sleeve	1	51	SA59.V2.51	Anvil	1
25	SA59.V2.25	O-Ring	1	52	SA59.V2.52	Anvil Washer	1
26	SA59.V2.26	Reverse Valve	1	53	SA59.V2.53	O-Ring	1
27	SA59.V2.27	Air Regulator	1	54	SA59.V2.54	Anvil Collar	1
28	SA59.V2.28	O-Ring	1				

1. SAFETY INSTRUCTIONS

- ✓ Follow all workshop safety rules, regulations, and conditions when using wrench.
- ⚠ **WARNING!** Disconnect from air supply before changing accessories or servicing.
- ✓ Maintain the wrench in good condition and replace any damaged or worn parts. Use genuine parts only. Non-authorized parts may be dangerous and will invalidate the warranty.
- ⚠ **WARNING!** Check correct air pressure is maintained and not exceeded. We recommend 90psi.
- ✓ Keep air hose away from heat, oil and sharp edges. Check air hose for wear before each use and ensure that all connections are secure.
- ✓ Only use impact sockets which are specifically designed for use with an impact wrench.
- ✓ Wear approved safety eye/face shield, ear defenders, and hand protection.
- ⚠ **WARNING!** Due to the possible presence of asbestos dust from brake linings, when working around vehicle brake systems we recommend you wear suitable respiratory protection.
- ✓ Maintain correct balance and footing. Ensure the floor is not slippery and wear non-slip shoes.
- ✓ Keep children and non essential persons away from the working area.
- ✗ DO NOT use the wrench for a task it is not designed to perform.
- ⚠ **WARNING! DO NOT** use wrench if damaged or thought to be faulty. (Contact Service Agent).
- ✗ DO NOT use wrench unless you have been instructed in its use by a qualified person.
- ✗ DO NOT carry the wrench by the air hose, or yank the hose from the air supply.
- ✗ DO NOT operate wrench if you are tired, under the influence of alcohol, drugs or intoxicating medication.
- ✗ DO NOT carry wrench with your hand on the power trigger in order to avoid unintentional starting.
- ✗ DO NOT direct air from the air hose at yourself or others.
- ✓ When not in use disconnect from air supply and store in a safe, dry, childproof location.

2. INTRODUCTION & SPECIFICATIONS

Tough professional air impact gun fitted with a smooth performing, power-pin type clutch. Features an adjustable air/torque control and reversible action plus spring balance anchorage point. Fitted with standard 3/4" square drive anvil. Suitable for general garage use.

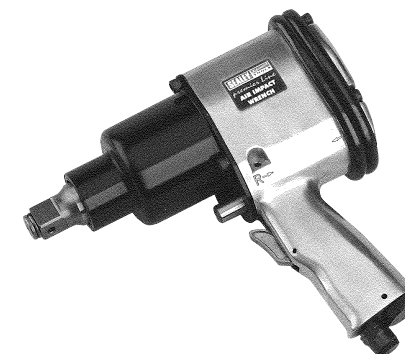

Drive size 3/4"
 Working/Max torque 900/1000ft/lb
 Ultimate torque 1050ft/lb
 Air consumption18cfm
 Operating pressure90psi
 Air inlet size 1/4" BSP
 Weight5kg

NOTE: It is our policy to continually improve products and as such we reserve the right to alter data, specifications and component parts without prior notice. **IMPORTANT:** No liability is accepted for incorrect use of this equipment. **WARRANTY:** Guarantee is 12 months from purchase date, proof of which will be required for any claim. **INFORMATION:** For a copy of our latest catalogue and promotions, call us on 01284 757525 and leave your full name and address including your postcode.

3. PREPARING WRENCH FOR USE

3.1. Air Supply

- 3.1.1. Ensure wrench air valve (or trigger) is in the "off" position before connecting to the air supply.
- 3.1.2. You will require an air pressure of 90psi, and an air flow according to specification.
- 3.1.3. **WARNING!** Ensure the air supply is clean and does not exceed 90 psi while operating the wrench. Too high an air pressure and unclean air will shorten the product life due to excessive wear, and may be dangerous causing damage and/or personal injury.
- 3.1.4. Drain the air tank daily. Water in the air line will damage the wrench.
- 3.1.5. Clean air inlet filter weekly. Recommended hook-up procedure is shown in fig 1.
- 3.1.6. Line pressure should be increased to compensate for unusually long air hoses (over 8 metres). The minimum hose diameter should be 1/4" I.D. and fittings must have the same inside dimensions.
- 3.1.7. Keep hose away from heat, oil and sharp edges. Check hose for wear, and make certain that all connections are secure.

3.2. Couplings.

Vibration may cause failure if a quick change coupling is connected directly to the wrench. To overcome this, connect a leader hose to the wrench. A quick change coupling may then be used to connect the leader hose to the air line recoil hose. See fig 1 & 2.

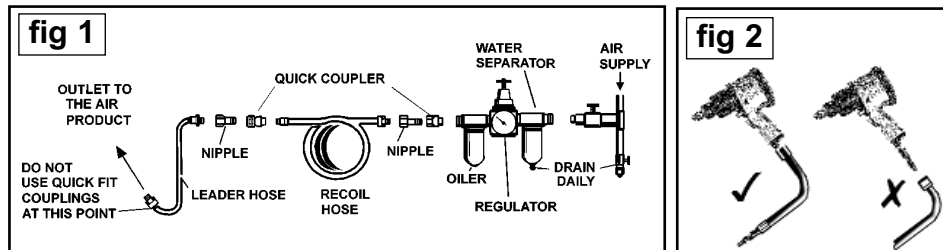

4. OPERATING INSTRUCTIONS

- WARNING!** Ensure you read, understand and apply safety instructions before use.

- 4.1. Only use impact sockets which are specifically designed for use with an impact wrench.
- 4.2. Connect the wrench to the air hose as in chapter 3.
- 4.3. Place the socket over the subject nut and depress the trigger to operate the wrench.
- 4.4. To change direction push the button at the top of the handle. Direction of "R" for reverse and "F" for forward.
- 4.5. The flow of air may be regulated by adjusting flow valve at the base of the handle.
DO NOT use any additional force upon the wrench in order to remove a nut.
DO NOT allow wrench to free run for an extended period of time as this will shorten its life.

5. MAINTENANCE

- WARNING!** Disconnect wrench from air supply before changing accessories, servicing or performing maintenance. Replace or repair damaged parts. *Use genuine parts only. Non-authorized parts may be dangerous and will invalidate the warranty.*
- 5.1. Lubricate the air wrench daily with a few drops of Sealey air tool oil dripped into the air inlet.
 - 5.2. Check and top up the gearbox by removing the set screw (item 14 on the parts diagram).
 - 5.3. Clean the wrench after use. DO NOT use worn, or damaged sockets.
 - 5.4. Loss of power or erratic action may be due to the following:
 - a) Excessive drain on the air line. Moisture or restriction in the air pipe. Incorrect size or type of hose connectors. To remedy check the air supply and follow instructions in chapter 3.
 - b) Grit or gum deposits in the wrench may also reduce performance. Remove the strainer, clean it and flush the wrench out with gum solvent oil or an equal mixture of SAE No 10 oil and paraffin. Allow to dry before use.
 - 5.5. For a full service contact your local Sealey service agent.
 - 5.6. When not in use, disconnect from air supply, clean wrench and store in a safe, dry, childproof location.

Declaration of Conformity



We, the sole importer into the UK, declare that the product listed here is in conformity with the following EEC standards and directives. The construction file for this product is held by the Manufacturer and may be inspected, by a national authority, upon request to Jack Sealey Ltd.

Air Impact Wrench
Model: SA59.V2

98/37/EC Machinery Directive
93/68/EEC Marking Directive

Signed by Mark Sweetman

26th June 2002

For Jack Sealey Ltd. Sole importer into the UK
of Sealey Power Tools.