

PARTS LIST FOR: 100mm EXTRA HEAVY DUTY ANGLE GRINDER Model: SA44

Issue:2
Issue Date: ...100305

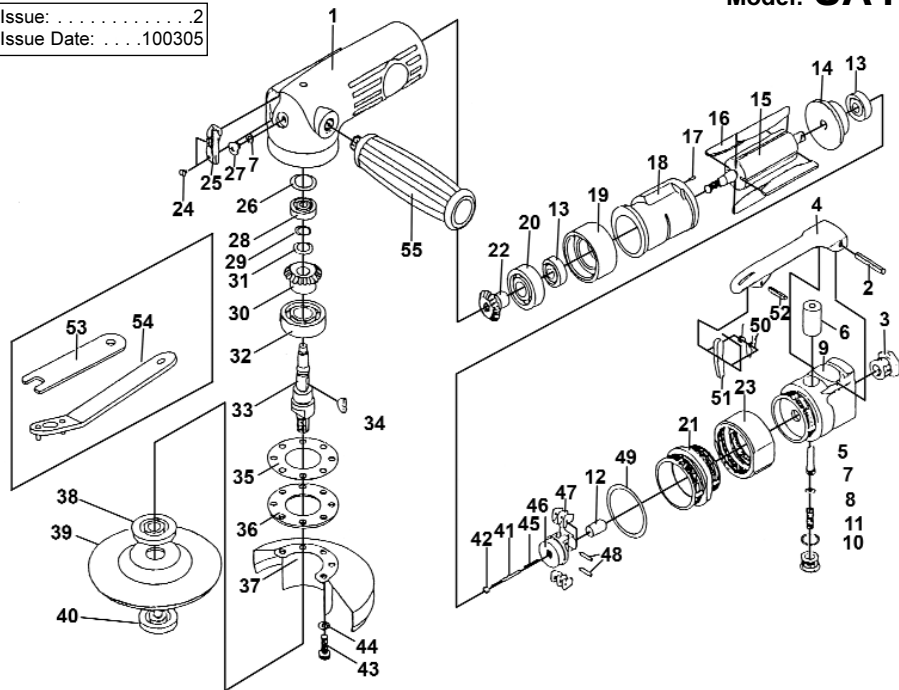

| ITEM | PART NO. | DESCRIPTION | ITEM | PART NO. | DESCRIPTION | ITEM | PART NO. | DESCRIPTION |
|------|----------|------------------------|------|----------|----------------|------|----------|----------------|
| 1 | SA44T/01 | MOTOR HOUSING | 20 | 6201Z | BEARING | 39 | PTC/100G | GRINDING DISC |
| 2 | SA44T/02 | SPRING PIN | 21 | SA44T/21 | LOCK NUT | 40 | SA44T/40 | FLANGE NUT |
| 3 | SA44T/03 | AIR INLET | 22 | SA44T/22 | BEVEL PINION | 41 | SA44T/41 | ADJUST SCREW |
| 4 | SA44T/04 | TRIGGER | 23 | SA44T/23 | COUPLING NUT | 42 | SA44T/42 | ADJUST NUT |
| 5 | SA44T/05 | VALVE STEM | 24 | SA44T/24 | SCREW | 43 | SA44T/43 | CAP SCREW |
| 6 | SA44T/06 | BUSHING | 25 | SA44T/25 | DEFLECTOR | 44 | SA44T/44 | WASHER |
| 7 | SA44T/07 | O-RING | 26 | SA44T/26 | SPACER | 45 | SA44T/45 | SPRING |
| 8 | SA44T/08 | VALVE SPRING | 27 | SA44T/27 | SCREW | 46 | SA44T/46 | GOVERNOR |
| 9 | SA44T/09 | THROTTLE VALVE HOUSING | 28 | 626ZZ | BEARING | 47 | SA44T/47 | PENDULUM |
| 10 | SA44T/10 | THROTTLE LEVER PLUG | 29 | SA44T/29 | RETAINING RING | 48 | SA44T/48 | SPRING PIN |
| 11 | SA44T/11 | O-RING | 30 | SA44T/30 | BEVEL GEAR | 49 | SA44T/49 | O-RING |
| 12 | SA44T/12 | PLUNGER | 31 | SA44T/31 | WAVE WASHER | 50 | SA44T/50 | TORSION SPRING |
| 13 | 608ZZ | BEARING | 32 | 6202ZZ | BEARING | 51 | SA44T/51 | LEVER LOCK |
| 14 | SA44T/14 | END PLATE | 33 | SA44T/33 | SPINDLE | 52 | SA44T/52 | SPRING PIN |
| 15 | SA44T/15 | ROTOR | 34 | SA44T/34 | KEY | 53 | SA44T/53 | SPANNER |
| 16 | SA44T/16 | ROTOR BLADE | 35 | SA44T/35 | GASKET | 54 | SA44T/54 | PIN WRENCH |
| 17 | SA44T/17 | SPRING PIN | 36 | SA44T/36 | RETAINER | 55 | SA44T/55 | HANDLE |
| 18 | SA44T/18 | CYLINDER | 37 | SA44T/37 | DISC COVER | | | |
| 19 | SA44T/19 | FRONT PLATE | 38 | SA44T/38 | FLANGE | | | |

NOTE: It is our policy to continually improve products and as such we reserve the right to alter data, specifications and component parts without prior notice. **IMPORTANT:** No liability is accepted for incorrect use of this equipment. **WARRANTY:** Guarantee is 12 months from purchase date, proof of which will be required for any claim. **INFORMATION:** For a copy of our latest catalogue and promotions call us on 01284 757525 and leave your full name and address, including postcode.

INSTRUCTIONS FOR: 100mm EXTRA HEAVY DUTY ANGLE GRINDER Model: SA44

Thank you for purchasing a Sealey Product. Manufactured to a high standard this product will, if used according to these instructions and properly maintained, give you years of trouble free performance.



IMPORTANT: PLEASE READ THESE INSTRUCTIONS CAREFULLY. NOTE THE SAFE OPERATIONAL REQUIREMENTS, WARNINGS AND CAUTIONS. USE THIS PRODUCT CORRECTLY AND WITH CARE FOR THE PURPOSE FOR WHICH IT IS INTENDED. FAILURE TO DO SO MAY CAUSE DAMAGE AND/OR PERSONAL INJURY AND WILL INVALIDATE THE WARRANTY. PLEASE KEEP INSTRUCTIONS SAFE FOR FUTURE USE.

1. SAFETY INSTRUCTIONS

- WARNING!** Ensure Health & Safety, local authority, and general workshop practice regulations are adhered to when using this equipment.
- WARNING!** Disconnect from air supply before changing accessories or servicing.
- ✓ Maintain the grinder in good condition (use an authorised service agent).
- ✓ Replace or repair damaged parts. Use genuine parts only. Unauthorised parts may be dangerous and will invalidate the warranty.
- ✓ Use in a suitable work area. Keep area free from unrelated materials and ensure that there is adequate lighting.
- ✓ Before each use check abrasive disc for condition. If worn or damaged replace immediately.
- ✓ Ensure the speed rating (rpm) of the disc is the same as, or greater than, the speed rating of the grinder.
- ✓ Ensure there are no flammable or combustible materials near the work area.
- WARNING!** Always wear approved eye (or face) and hand protection when operating the grinder.
- ✓ Use face, dust, or respiratory protection in accordance with COSHH regulations.
- ✓ Depending on the task, grinder noise level may exceed 85dB in which case wear safety ear defenders.
- ✓ Remove ill fitting clothing. Remove ties, watches, rings, other loose jewellery and contain and/or tie back long hair.
- ✓ Wear appropriate protective clothing and keep hands and body clear of working parts.
- ✓ Maintain correct balance and footing. Ensure the floor is not slippery and wear non-slip shoes.
- ✓ Keep children and unauthorised persons away from the working area.
- ✓ Check moving parts alignment on a regular basis.
- ✓ Ensure workpiece is secure before operating the grinder. Never hold a workpiece by hand.
- ✓ Check the workpiece to ensure there are no protruding screws, bolts, nuts etc.
- ✓ Avoid unintentional starting.
- WARNING!** Ensure correct air pressure is maintained and not exceeded. Recommended pressure 70-90psi
- ✓ Keep air hose away from heat, oil and sharp edges. Check air hose for wear before each use and ensure that all connections are secure.
- ✓ Prolonged exposure to vibration from this grinder poses a health risk. It is the owner's responsibility to correctly assess the potential hazard and issue guidelines for safe periods of use and offer suitable protective equipment.
- x **DO NOT** use the grinder for a task it is not designed to perform.
- x **DO NOT** operate grinder if any parts are damaged or missing as this may cause failure and/or personal injury.
- WARNING!** DO NOT grind any materials containing asbestos.
- x **DO NOT** carry the grinder by the hose, or yank the hose from the air supply.
- x **DO NOT** force, or apply heavy pressure to, the grinder, let the tool do the work.
- x **DO NOT** place air line attachments close to your face and do not point at other people or animals.
- x **DO NOT** operate grinder when you are tired or under the influence of alcohol, drugs or intoxicating medication.
- x **DO NOT** use grinder where there are flammable liquids, solids or gases such as paint solvents and including waste wiping or cleaning rags etc.
- x **DO NOT** carry the grinder with your finger on the power lever.
- x **DO NOT** direct air from the air line at yourself or others.
- ✓ When not in use disconnect from air supply and store in a safe, dry, childproof location.

DANGER OF FIRE/EXPLOSION HAZARD

- WARNING!** The grinding process can produce streams of sparks which are a potential source of ignition especially when grinding metal.
- x **DO NOT** use the grinder where there are flammable liquids, solids or gases.
- x **DO NOT** allow grinder sparks to make contact with the operator's clothing or any other fabric such as cleaning rags. Fabrics contaminated with flammable materials such as petrol, oil, grease, paint and solvents are a particular fire hazard.
- ✓ To reduce the risk of clothing catching fire the operator should wear wool or cotton outer garments treated with a fire retardant in preference to man-made fibres.

1.2. LEAD PAINT WARNING!

Paint once contained lead as a traditional ingredient. Contact with the dust from the removal of such paint is toxic and must therefore be avoided. The following action must be taken before using the grinder on a surface that you suspect may contain lead paint.

1. User must determine potential hazard relating to age of paint to be removed (modern paints do not have lead content).
2. **DANGER!** Keep all people and pets away from the working area. The following are particularly vulnerable to the effects of lead paint dust: *Expectant women, babies and children.*
3. We recommend personal protection by using the following safety items:
 - a) Paint Spray Respirator (Our ref SSP16EN)
 - b) PE Coated Hooded Coverall (Our ref SSP266).
 - c) Latex Gloves (Our ref SSP24).
4. Take adequate measures to contain the paint dust, flakes and scrapings.
5. Continue to wear safety equipment as in (3) above and thoroughly clean all areas when work is complete. Ensure paint waste is disposed of in sealed bags or containers.

Risk of Hand Arm Vibration Injury

Extra Heavy Duty Angle Grinder Model No. SA44 when operated in accordance with these instructions and tested in accordance with EN 28662-2: 1994 results in the following vibration emission declared in accordance with

BS EN12096: 1996.

Measured vibration emission value: 4.0m/s²

Uncertainty: 1.6m/s²

These values are suitable for comparison with emission levels of other tools that have been subject to the same test.

This tool may cause hand-arm vibration syndrome if its use is inadequately managed.

Recommended Measures to reduce risk of hand-arm vibration syndrome:

This tool should not be used by an individual regularly for more than 6.4 hours in any 8 hour period.

This duration of use should be reduced if the individual is exposed to hand-arm vibration from other sources.

2. INTRODUCTION & SPECIFICATION

The SA44 is suitable for general/heavy workshop use and has a polished and well balanced aluminium body with precision bevel gears giving quiet and smooth operation. Fitted with a throttle safety catch and supplied with a grinding disc, side handle and flange nut spanners.

Disc Size 100mm
Free Speed 12000rpm
Operating Pressure 90psi
Air Consumption 6cfm
Air Inlet 1/4" BSP

Sound Pressure 89dB(A)
Vibration 4.0m/s²
Weight 1.9kg
Replacement Disc Part No. PTC/100G

3. PREPARING GRINDER FOR USE

3.1 AIR SUPPLY

Recommended hook-up procedure is shown in fig 1.

- 3.1.1 Ensure the grinder air valve (or throttle) is in the "off" position before connecting to the air supply.
- 3.1.2 You will require an air pressure between 70-90psi, and an air flow according to the specification above.
- 3.1.3 **WARNING!** Ensure the air supply is clean and does not exceed 90 psi while operating the grinder. Too high an air pressure and unclean air will cause excessive wear, and may be dangerous, causing damage and/or personal injury.
- 3.1.4 Drain the air tank daily. Water in the air line will damage the grinder and invalidate your warranty.
- 3.1.5 Clean air inlet filter weekly. Recommended hook-up procedure is shown in fig 1.
- 3.1.6 Line pressure should be increased to compensate for unusually long air hoses (over 8 metres). The minimum hose diameter should be 1/4" I.D. and fittings must have the same inside dimensions.
- 3.1.7 Keep hose away from heat, oil and sharp edges. Check hoses for wear, and make certain that all connections are secure.

3.2 COUPLINGS

Vibration may cause failure if a quick change coupling is connected directly to the air sander. To overcome this, connect a leader hose - Sealey model number AH2R or AH2R/38 - to the grinder. A quick change coupling may then be used to connect the leader hose to the air line recoil hose. See figs. 1 & 2.

fig. 1

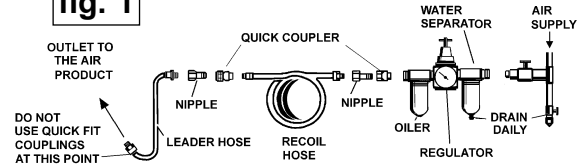
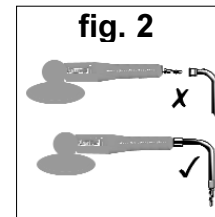

fig. 2



4. OPERATING INSTRUCTIONS

- WARNING! Ensure you read, understand and apply safety instructions before use.**

4.1 ASSEMBLY

- 4.1.1 The SA44 comes with a disc, handle and two spanners.
- 4.1.2 The handle screws into the left-hand side of the head.
- 4.1.3 Remove the disc locking flange nut from the grinder spindle. Use spanners supplied to hold the spindle and loosen/tighten the lock nut.
- 4.1.4 Fit the grinding disc to the spindle and retain with the flange nut. Use only discs with speed ratings equal to, or higher than, the speed rating of the grinder.
- 4.1.5 Connect air supply to grinder. Push safety catch forward with thumb and squeeze the control valve lever to check that the grinder is working correctly.

4.2 OPERATING

DO NOT apply excessive pressure, let the grinder do the work for you. Start the grinder and bring the disc to the work surface evenly and slowly. Move the grinder back and forth in overlapping areas. Remove the grinding disc from the work surface before stopping the grinder. Regularly check the condition of the disc and always change if worn, cracked or otherwise damaged.
DO NOT allow grinder to run off the workpiece for an extended period of time as this will shorten the life of bearings.

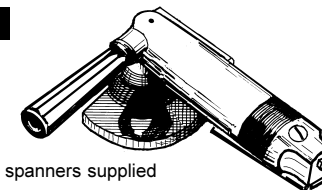

5. MAINTENANCE

- WARNING!** Disconnect grinder from air supply before changing disc, servicing or performing maintenance. Replace or repair damaged parts. *Use genuine parts only. Unauthorised parts may be dangerous and will invalidate the warranty.*
- 5.1 Lubricate the grinder daily with a few drops of good grade air tool oil, such as Sealey ATO/500 or ATO1000, dripped into the air inlet before use or dispensed automatically through an air system oiler, such as Sealey model SA100L.
 - 5.2 Clean the grinder after use and change the disc when worn or damaged.
 - 5.3 Loss of power or erratic action may be due to the following:
 - a) Excessive drain on the air supply. Moisture or restriction in the air line. Incorrect size or type of hose connectors. To remedy check the air supply and follow instructions in Section 3.
 - b) Grit or gum deposits in the grinder may also reduce performance. Flush the grinder with gum solvent oil or an equal mixture of SAE No 10 oil and kerosene. Allow to dry before use.
If you continue to experience problems, contact your local Sealey service agent.
 - 5.4 For a full service contact your local Sealey service agent.
 - 5.5 When not in use, disconnect from air supply, clean grinder and store in a safe, dry, childproof location.

Declaration of Conformity

 We, the sole importer into the UK, declare that the product listed here is in conformity with the following standards and directives. The construction file for this product is held by the Manufacturer and may be inspected, by a national authority, upon request to Jack Sealey Ltd.

Extra Heavy Duty Angle Grinder
Model: SA44
98/37/EC Machinery Directive
93/68/EEC Marking Directive

Signed by Mark Sweetman

For Jack Sealey Ltd. Sole importer into the UK of Sealey Power Tools.

10th March 2005