

## 7. PARTS LIST

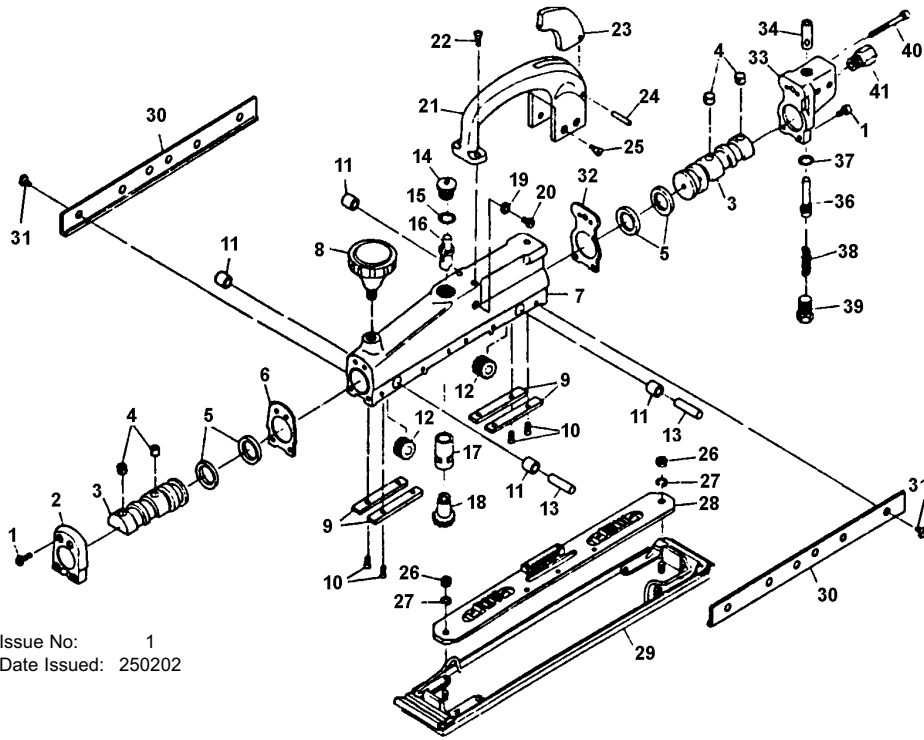

Issue No: 1  
Date Issued: 250202

Item	Part No.	Description	Item	Part No.	Description
1	SA32/01	Socket Head Screw	21	SA32/21	Handle
2	SA32/02	Front Cap	22	SA32/22	Phillips Head Screw
3	SA32/03	Piston	23	SA32/23	Trigger
4	SA32/04	Plug	24	SA32/24	Roll Pin
5	SA32/05	Piston Ring	25	SA32/25	Phillips Head Screw
6	SA32/06	Front Gasket	26	SA32/26	Hex. Nut
7	SA32/07	Body	27	SA32/27	Washer
8	SA32/08	Knob	28	SA32/28	Carrier
9	SA32/09	Wear Plate	29	SA32/29	Pad Assembly
10	SA32/10	Socket Head Screw	30	SA32/30	Side Strap
11	SA32/11	Bushing	31	SA32/31	Phillips Head Screw
12	SA32/12	Gear	32	SA32/32	Rear Gasket
13	SA32/13	Gear Shaft	33	SA32/33	Rear Cap
14	SA32/14	Plunger	34	SA32/34	Bushing
15	SA32/15	O-ring	36	SA32/36	Valve Pin
16	SA32/16	Adjuster Shaft	37	SA32/37	O-ring
17	SA32/17	Actuator Valve	38	SA32/38	Valve Spring
18	SA32/18	Actuator Gear	39	SA32/39	Valve Plug
19	SA32/19	Washer	40	SA32/40	Socket Head Screw
20	SA32/20	Flat Head Screw	41	SA32/41	Hose Adaptor

**NOTE:** It is our policy to continually improve products and as such we reserve the right to alter data, specifications and component parts without prior notice. **IMPORTANT:** No liability is accepted for incorrect use of this equipment. **WARRANTY:** Guarantee is 12 months from purchase date, proof of which will be required for any claim. **INFORMATION:** For a copy of our latest catalogue and promotions call us on 01284 757525 and leave your full name and address, including postcode.



Sole UK Distributor, Sealey Group, Bury St. Edmunds, Suffolk.

01284 757500

01284 703534

E-mail: sales@sealey.co.uk



INSTRUCTIONS FOR

# AIR OPERATED TWIN PISTON IN-LINE SANDER

Model: **SA32**

Thank you for purchasing a Sealey Product. Manufactured to a high standard this product will, if used according to these instructions and properly maintained, give you years of trouble free performance.



**IMPORTANT:** PLEASE READ THESE INSTRUCTIONS CAREFULLY. NOTE THE SAFE OPERATIONAL REQUIREMENTS, WARNINGS AND CAUTIONS. USE THIS PRODUCT CORRECTLY AND WITH CARE FOR THE PURPOSE FOR WHICH IT IS INTENDED. FAILURE TO DO SO MAY CAUSE DAMAGE AND/OR PERSONAL INJURY AND WILL INVALIDATE THE WARRANTY. PLEASE KEEP INSTRUCTIONS SAFE FOR FUTURE USE.

## 1. SAFETY INSTRUCTIONS

- WARNING!** Ensure Health & Safety, local authority and general workshop practice regulations are adhered to when using this equipment.
- WARNING!** Disconnect from air supply before changing accessories or servicing.
- ✓ Maintain the sander in good condition (use an authorised service agent).
- ✓ Replace or repair damaged parts. Use genuine parts only. Unauthorised parts may be dangerous and will invalidate the warranty.
- ✓ Use in suitable, clean and tidy work area, free from unrelated materials. Ensure that there is adequate lighting.
- ✓ Before each use check abrasive for condition. If worn or damaged replace immediately.
- ✓ Ensure the correct abrasive pad size is used.
- ✓ Ensure there are no flammable or combustible materials near the work area.
- WARNING!** Always wear approved eye or face and hand protection when operating the sander.
- ✓ Use face, dust, or respiratory protection in accordance with COSHH regulations.
- ✓ Depending on the task, sander noise level may exceed 85dB, in which case wear safety ear defenders.
- ✓ Remove ill fitting clothing. Remove ties, watches, rings and other loose jewellery and contain and/or tie back long hair.
- ✓ Wear appropriate protective clothing and keep hands and body clear of working parts.
- ✓ Maintain correct balance and footing. Ensure the floor is not slippery and wear non-slip shoes.
- ✓ Keep children and unauthorised persons away from the work area.
- ✓ Check moving parts alignment on a regular basis.
- ✓ Ensure that workpiece is secure before operating the sander. Never hold a workpiece by hand.
- ✓ Check the workpiece to ensure that there are no protruding screws, bolts, nuts, nails, stones, etc.
- ✓ Avoid unintentional starting.
- WARNING!** Ensure correct air pressure is maintained and not exceeded. Recommended pressure 70-90psi.
- ✓ Keep air hoses away from heat, oil and sharp edges. Check air hose for wear before each use and ensure that all connections are secure.
- ✓ Prolonged exposure to vibration from this sander poses a health risk. It is the owner's responsibility to correctly assess the potential hazard and issue guidelines for safe periods of use and offer suitable protective equipment.
- x DO NOT use the sander for a task it is not designed to perform.
- x DO NOT operate sander if any parts are damaged or missing as this may cause failure and/or personal injury.
- WARNING!** DO NOT sand any materials containing asbestos.
- x DO NOT carry the sander by the hose, or yank the hose from the air supply.
- x DO NOT force, or apply heavy pressure to, the sander. Let the sander do the work.
- x DO NOT place attachments close to your face and do not point at other persons or animals.
- x DO NOT operate sander when you are tired or under the influence of alcohol, drugs or intoxicating medication.
- x DO NOT use sander where there are flammable liquids, solids or gases such as paint solvents and including waste wiping or cleaning rags etc.
- x DO NOT carry the sander with your hand on the power lever.
- x DO NOT direct air from the air hose at yourself or others.
- ✓ When not in use disconnect from air supply and store in a safe, dry, childproof location.



### 1.2. LEAD PAINT WARNING!

Paint once contained lead as a traditional ingredient. Contact with the dust from the removal of such paint is toxic and must therefore be avoided. The following action must be taken before using the sander on a surface that you suspect may contain lead paint.

1. User must determine potential hazard relating to age of paint to be removed. (Modern paints do not have lead content).
2. **DANGER!** Keep all persons and pets away from the work area. The following are particularly vulnerable to the effects of lead paint dust: *Pregnant women, babies and children.*
3. We recommend personal protection by using the following safety items:
  - a) Paint Spray Respirator (Our ref SSP16EN)
  - b) PE Coated Hooded Coverall (Our ref SSP266).
  - c) Latex Gloves (Our ref SSP24).
4. Take adequate measures to contain the paint dust, flakes and scrapings.
5. Continue to wear safety equipment as in (3) above and thoroughly clean all areas when task is complete. Ensure paint waste is disposed of, in sealed bags or containers, according to local regulations.

## 2. INTRODUCTION & SPECIFICATION

The SA32 has a twin piston configuration which powers the base plate on the forward and backward stroke. This arrangement also reduces vibration for more comfortable operation.

Pad Size	.....70x400mm	Air Inlet	.....1/4"BSP
Stroke Length	......25mm	Sound	......98.0dB(A)
Free Speed	......2500spm		.....97.7dB(C)
Operating Pressure	......90psi	Vibration Level	......4m/s <sup>2</sup>
Air Consumption	......8cfm	Weight	......3kg

## 3. PREPARING SANDER FOR USE

### 3.1. Air Supply

- 3.1.1. Ensure the sander air valve (or throttle) is in the "off" position before connecting to the air supply.
- 3.1.2. You will require an air pressure between 70-90psi, and an air flow of 8cfm.
- 3.1.3.  **WARNING!** Ensure that the air supply is clean and does not exceed 90 psi while operating the sander. Too high an air pressure and/or unclean air will shorten the product life due to excessive wear, and may be dangerous, causing damage and/or personal injury.
- 3.1.4. Drain the air tank daily. Water in the air line will damage the sander **and will invalidate your warranty.**
- 3.1.5. Clean air inlet filter weekly. Recommended hook-up is shown in fig. 1.
- 3.1.6. Line pressure should be increased to compensate for unusually long air hoses (over 8 metres). The minimum hose and fittings internal diameter should be 1/4" I.D.
- 3.1.7. Keep hoses away from heat, oil and sharp edges. Check hoses for wear and make certain that all connections are secure.

### 3.2. Couplings

Vibration may cause failure if a quick connect coupling is connected directly to the air sander. To overcome this, connect a leader hose to the sander. A quick connect coupling may then be used to connect the leader hose to the air line recoil hose. See figs. 1 & 2.

fig. 1

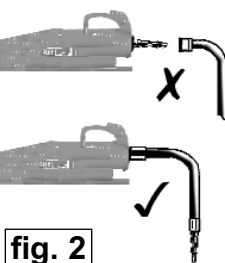
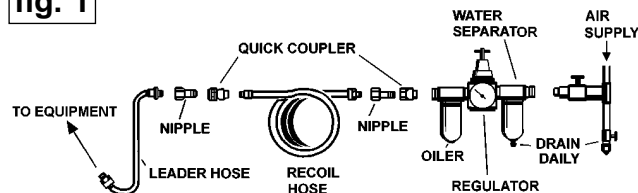

fig. 2

## 4. ASSEMBLY & OPERATION

**WARNING! Ensure you read, understand and apply safety instructions before use.**

### 4.1. Assembly

- 4.1.1. Lift front retaining spring arm and insert the sanding paper under the front of the spring. Replace retaining arm and the paper will be held in place. Attach the rear of the paper in the same manner.
- 4.1.2. Connect air supply to sander, press the control valve lever and check that the sander is working correctly.

### 4.2. Operating

Always use sanding paper appropriate for the job. Work progressively from coarse grades to finer grades. DO NOT go from coarse to fine in one step as it may be difficult to remove swirl marks left by the coarse grit. DO NOT apply excessive pressure, let the sander do the work for you. Start the sander and bring it to the work surface evenly and slowly. Move the sander back and forth in overlapping areas. Remove the sander from the work surface before turning off. Regularly check the sanding paper for wear and always change if cracked or damaged.

DO NOT allow sander to run in "idle" for an extended period of time as this will shorten the life of the bearings.

## 5. MAINTENANCE

**WARNING!** Disconnect sander from air supply before changing accessories, servicing or performing maintenance. Replace or repair damaged parts. *Use genuine parts only. Unauthorised parts may be dangerous and will invalidate the warranty.*

- 5.1. If the air supply does not have an oiler, lubricate the sander daily with a few drops of good grade air tool oil, such as Sealey ATO/500 or ATO/1000, dripped into the air inlet before use.
- 5.2. Clean the sander after use and change pad when required.
- 5.3. Loss of power or erratic action may be due to the following:
  - a) Excessive drain on the air line. Moisture or restriction in the air pipe. Incorrect size or type of hose connectors. To remedy, check the air supply and follow instructions in Section 3.
  - b) Grit or gum deposits in the sander may also reduce performance. If your model has an air strainer (located in the area of the air inlet), remove the strainer and clean it. Flush the sander out with gum solvent oil or an equal mixture of SAE 10 oil and kerosene. Allow to dry before use.

If you continue to experience problems, contact your local Sealey service agent.
- 5.4. When not in use, disconnect from air supply, clean sander and store in a safe, dry, childproof location.

## 6. DECLARATION OF CONFORMITY

### Declaration of Conformity



We, the sole importer into the UK, declare that the product listed here is in conformity with the following standards and directives. The construction file for this product is held by the manufacturer and may be inspected, by a national authority, upon request to Jack Sealey Ltd.

**Air Operated Twin Piston In-Line Sander**

**Model: SA32**

98/37/EC Machinery Directive  
93/68/EEC Marking Directive

Signed by Mark Sweetman

27th February 2002

For Jack Sealey Ltd. Sole importer into the UK of Sealey Power Tools.



Sole UK Distributor, Sealey Group, Bury St. Edmunds, Suffolk.

01284 757500

01284 703534

E-mail: sales@sealey.co.uk