



INSTRUCTIONS FOR:
**AIR/HYDRAULIC RIVETER HEAVY-DUTY
 VACUUM SYSTEM**
 MODEL No: **SA316.V2**

Thank you for purchasing a Sealey product. Manufactured to a high standard this product will, if used according to these instructions and properly maintained, give you years of trouble free performance.



Refer to
Instructions



Wear Eye
Protection

1. SAFETY

- WARNING!** Ensure Health & Safety, local authority, and general workshop practice regulations are adhered to when using this equipment.
- ✓ Familiarise yourself with this product's application and limitations, as well as the potential hazards peculiar to the riveter.
- WARNING!** Disconnect the riveter from the air supply before changing accessories, servicing or performing any maintenance.
- ✓ Maintain the riveter in good condition (use an authorised service agent).
- ✓ Replace or repair damaged parts. *Use genuine parts only. Unauthorised parts may be dangerous and will invalidate the warranty.*
- ✓ Use in a suitable work area. Keep area free from unrelated materials and ensure that there is adequate lighting.
- ✓ Keep the riveter clean for best and safest performance.
- WARNING!** Always wear approved eye (or face) and hand protection when operating the riveter.
- ✓ Maintain correct balance and footing. Do not over reach, ensure the floor is not slippery, wear non-slip shoes.
- ✓ Remove ill fitting clothing. Remove ties, watches, rings, loose jewellery. Contain or tie back long hair.
- ✓ Wear appropriate protective clothing and keep hands and body clear of working parts.
- ✓ Keep the riveter away from your body and at a safe distance from others.
- ✓ Keep children and unauthorised persons away from the working area.
- ✓ Secure non stable workpieces with a clamp, vice or other adequate holding device.
- ✓ Ensure that spent rivet stems are disposed of correctly and do not cause a hazard.
- WARNING!** Ensure correct air pressure is maintained and not exceeded. Recommended pressure:85-90psi.
- ✓ Keep air hose away from heat, oil and sharp edges. Check air hose for wear before each use, and ensure that all connections are secure.
- ✓ Avoid unintentional starting.
- x **DO NOT** use the riveter for a task it is not designed to perform.
- x **DO NOT** operate the riveter if any parts are damaged or missing as this may cause failure and/or personal injury.
- x **DO NOT** carry by the hose, or pull the hose from the air supply.
- x **DO NOT** get the riveter wet or use in damp or wet locations or areas where there is condensation.
- x **DO NOT** allow untrained persons to operate the riveter.
- x **DO NOT** operate the riveter when you are tired or under the influence of alcohol, drugs or intoxicating medication.
- x **DO NOT** direct air from the air hose at yourself or others.
- ✓ When not in use, disconnect from the air supply and store in a safe, dry, childproof location.

2. INTRODUCTION

Powerful, extra heavy-duty tool suitable for aluminium, steel, stainless steel rivets and structural rivets from 3/16" to 1/4". Trigger operated riveter with hardened steel jaw assembly and air-actuated vacuum rivet shaft collector. Resilient grip for added comfort and hanging loop for use with balancer. Supplied with three riveting nozzles, two spanners and oil can.

3. SPECIFICATIONS

Nozzle Sizes: 3/16"(4.8mm), 7/32"(5.6mm)1/4"(6.4mm)
 Air Consumption:4cfm
 Operating Pressure: 90psi
 Air Inlet Size: 1/4"BSP

Weight: 1.9kg
 Noise Power:84.8dB(A)
 Noise Pressure:73.8dB(A)
 Vibration Figure:0.44m/s²

4. AIR SUPPLY

4.1. Air Supply

- WARNING!** Ensure the air supply is clean and does not exceed 90psi while operating the riveter. Too high an air pressure and unclean air will cause excessive wear, and may be dangerous, causing damage and/or personal injury. Recommended hook-up procedure is shown in Fig.1.
- 4.1.1. Ensure the riveter air valve (or trigger) is not depressed before connecting to the air supply.
- 4.1.2. You will require an air pressure between 70-90psi, and an air flow according to the specification above.
- 4.1.3. Drain the air tank daily. Water in the air line will damage the riveter and invalidate your warranty.
- 4.1.4. Clean air inlet filter weekly.
- 4.1.5. Line pressure should be increased to compensate for unusually long air hoses (over 8 metres). The minimum hose diameter should be 1/4" I.D. and fittings must have the same inside dimensions.
- 4.1.6. Keep hose away from heat, oil and sharp edges. Check hoses for wear, and make certain that all connections are secure.

4.2. Couplings

Vibration may cause failure if a quick change coupling is connected directly to the riveter. To overcome this, connect a leader hose Sealey model number AH2R or AH2R/38 - to the riveter. A quick change coupling may then be used to connect the leader hose to the air line recoil hose. See figs.1 & 2.

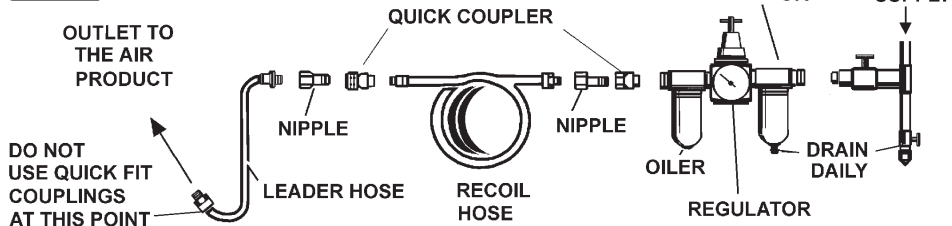
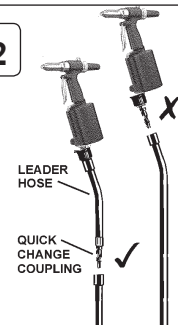
Fig.1**Fig.2**

5. OPERATION

- ❑ **WARNING! Ensure that you have read, understood and apply the safety instructions. This tool is designed for rivetting metal, primarily in workshops and garages. We do not recommend any other use.**

5.1. Fitting the Desired Nozzle.

- 5.1.1. Fit the supplied spanner over the nozzle and turn it anti-clockwise to remove it (Fig.3).
- 5.1.2. Fit the correct size nozzle for the rivet to be used and screw back into the frame head and tighten with the spanner.

5.2. Operation.

- 5.2.1. Ensure the air valve is in the closed position (Fig.4) before connecting the air supply.
- 5.2.2. Open the shut-off valve by sliding the knurled ring upwards (Fig.4).
- 5.2.3. Place the desired size rivet into the nozzle, ensuring the nozzle is the correct size for the rivet.
- 5.2.4. Insert the rivet into the workpiece as far as it will go and squeeze the trigger. The rivet will be compressed and the spent mandrel will be sucked into the spent mandrel bottle.
- 5.2.5. When the spent mandrel bottle is full, close the shut-off valve, unscrew, empty and replace (Fig.4).

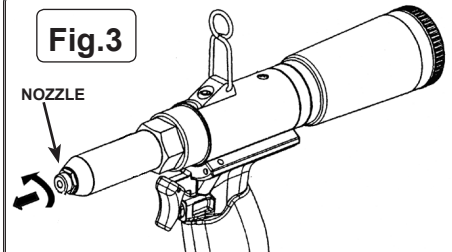
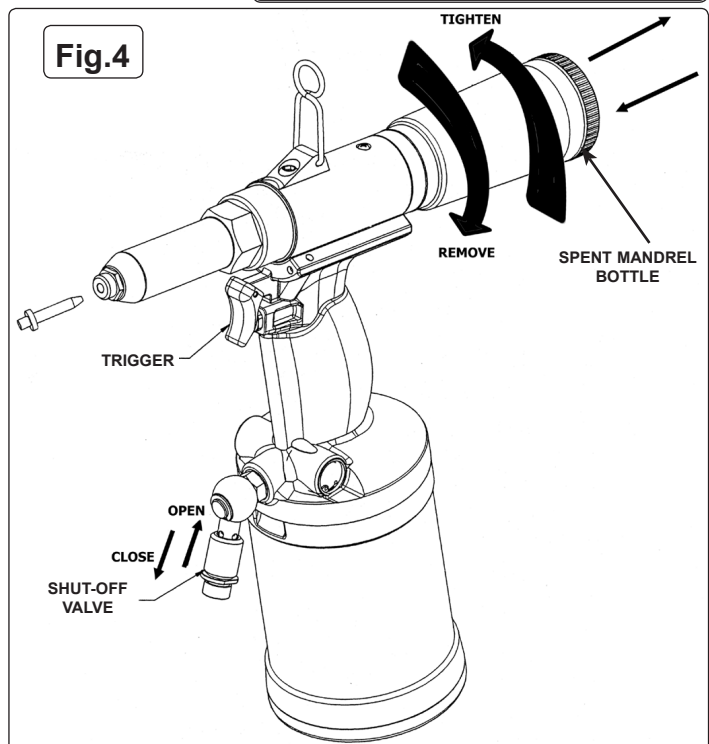
Fig.3**Fig.4**

6. MAINTENANCE

- ❑ **WARNING! Ensure you disconnect the tool from the air supply system before attempting any service or maintenance.**

- 6.1. Maintain the tool with care. Keep it oiled for optimum performance.
- 6.2. Lubricate the air tool daily with a high quality air tool oil, (such as Sealey Part No. ATO/500 or ATO/1000). Add oil to the hydraulic system occasionally.
- 6.3. Unscrew the oil tank plug (Fig.5) and fill with SAE 10 oil until the oil level reaches the bottom of the plug hole. It is recommended that the oil seal, part No: SA316.49 be replaced during this procedure.
- 6.3.2. Re-fit the oil plug screw.
- 6.4. Eventually the jaws will wear and require replacement.
- 6.4.1. Remove the nozzle and frame head (Fig.6) using the supplied spanners.
- 6.4.2. Undo and remove the jaw housing from the jaw housing coupler (Fig.7).
- 6.4.3. Withdraw the jaws and replace with a new set. If the jaw pusher and spring fall out, put the spring back first and then the jaw pusher followed by the jaws. For a further reference consult the parts diagram at the back of this manual for correct part orientation.
- 6.4.4. Fit the frame head and tighten.
- 6.4.5. When the jaws are replaced check that the jaw distance from the main body is 84mm using the guide on the spanner as shown in Fig.9.
- 6.5. Factors that may inhibit performance:
Loss of power or erratic action may be caused by reduced compressor output, an excessive drain on the air line, moisture or restrictions in air pipes or the use of hose connections of improper size. Grit or gum deposits in the tool may cut power and can be corrected by cleaning the air strainer and flushing out the tool with gum solvent oil or an equivalent de-greaser. If all outside conditions are in order, disconnect the tool from the air supply, disassemble and replace any worn or damaged parts with Sealey original parts. Clean all parts, reassemble the tool and lubricate.
- 6.6. Store the tool in a safe, dry, secure environment.

Oil

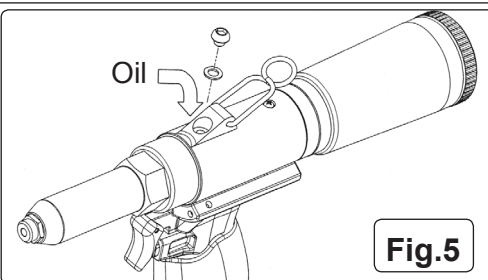
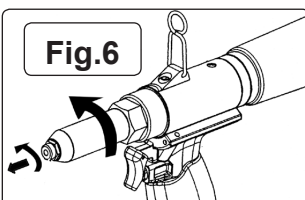
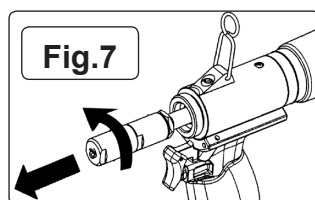
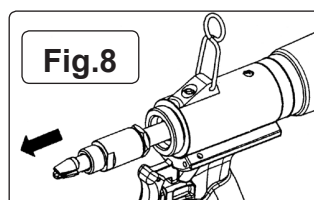
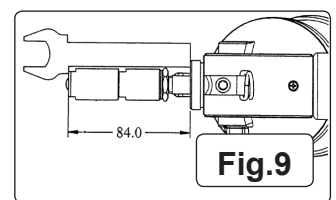
**Fig.5****Fig.6****Fig.7****Fig.8****Fig.9**

7. TROUBLESHOOTING

PROBLEM	CAUSE	REMEDY
Rivet jammed.	Wrong size rivet/nozzle.	Use the correct size nozzle for the rivet
	Filings jammed in jaw housing.	Snap off rivet head, dismantle jaw housing and pull out the rivet mandrel. Use an airline to blow out the filings, oil and re-assemble the jaw housing.
	Filings jammed in nozzle.	Clean out the nozzle.
No suction.	The shut-off valve has not been opened.	Open shut-off valve.
Air leaking.	Damaged O-rings.	O-rings must be replaced.
	Loose screws.	Tighten screws.
Tool runs slow or suffers a loss of power.	Air line is loose.	Re-install and tighten airline.
	Exhaust port is blocked.	Clean out exhaust port.
	Operating pressure is too low.	Increase the operating pressure to 85-95psi. If the pressure exceeds 105-110psi, the safety valve will operate.



Environmental Protection



Recycle unwanted materials instead of disposing of them as waste. All tools, accessories and packaging should be sorted, taken to a recycling centre and disposed of in a manner which is compatible with the environment. When the product becomes completely unserviceable and requires disposal, drain off any fluids (if applicable) into approved containers and dispose of the product and the fluids according to local regulations.

NOTE: It is our policy to continually improve products and as such we reserve the right to alter data, specifications and component parts without prior notice.

IMPORTANT: No liability is accepted for incorrect use of this product.

WARRANTY: Guarantee is 12 months from purchase date, proof of which will be required for any claim.



Sole UK Distributor, Sealey Group,
Kempson Way, Suffolk Business Park,
Bury St. Edmunds, Suffolk,
IP32 7AR

 01284 757500

 01284 703534



www.sealey.co.uk



sales@sealey.co.uk

WARNING! – Risk of Hand Arm Vibration Injury.

This tool may cause Hand Arm Vibration Syndrome if its use is not managed adequately.

This tool is subject to the vibration testing section of the Machinery Directive 2006/42/EC.

This tool is to be operated in accordance with these instructions.

Measured vibration emission value (a):0.44 m/s²

Please note that the application of the tool to a sole specialist task may produce a different average vibration emission. We recommend that a specific evaluation of the vibration emission is conducted prior to commencing with a specialist task.

A health and safety assessment by the user (or employer) will need to be carried out to determine the suitable duration of use for each tool.

NB: Stated Vibration Emission values are type-test values and are intended to be typical.

Whilst in use, the actual value will vary considerably from and depend on many factors.

Such factors include; the operator, the task and the inserted tool or consumable.

NB: ensure that the length of leader hoses is sufficient to allow unrestricted use, as this also helps to reduce vibration.

The state of maintenance of the tool itself is also an important factor, a poorly maintained tool will also increase the risk of Hand Arm Vibration Syndrome.

Health surveillance.

We recommend a programme of health surveillance to detect early symptoms of vibration injury so that management procedures can be modified accordingly.

Personal protective equipment.

We are not aware of any personal protective equipment (PPE) that provides protection against vibration injury that may result from the uncontrolled use of this tool. We recommend a sufficient supply of clothing (including gloves) to enable the operator to remain warm and dry and maintain good blood circulation in fingers etc. Please note that the most effective protection is prevention, please refer to the Correct Use and Maintenance section in these instructions. Guidance relating to the management of hand arm vibration can be found on the HSE website www.hse.gov.uk - Hand-Arm Vibration at Work.