

Thank you for purchasing a Sealey product. Manufactured to a high standard this product will, if used according to these instructions and properly maintained, give you years of trouble free performance.



IMPORTANT: PLEASE READ THESE INSTRUCTIONS CAREFULLY. NOTE THE SAFE OPERATIONAL REQUIREMENTS, WARNINGS & CAUTIONS. USE THE PRODUCT CORRECTLY AND WITH CARE FOR THE PURPOSE FOR WHICH IT IS INTENDED. FAILURE TO DO SO MAY CAUSE DAMAGE AND/OR PERSONAL INJURY AND WILL INVALIDATE THE WARRANTY. PLEASE KEEP INSTRUCTIONS SAFE FOR FUTURE USE.

1. SAFETY INSTRUCTIONS

1.1. ELECTRICAL SAFETY

WARNING! It is the responsibility of the owner and the operator to read, understand and comply with the following:

You must check all electrical products, before use, to ensure that they are safe. You must inspect power cables, plugs, sockets and any other connectors for wear or damage. You must ensure that the risk of electric shock is minimised by the installation of appropriate safety devices. A Residual Current Circuit Breaker (RCCB) should be incorporated in the main distribution board. We also recommend that a Residual Current Device (RCD) is used. It is particularly important to use an RCD with portable products that are plugged into a supply which is not protected by an RCCB. If in any doubt consult a qualified electrician. You may obtain a Residual Current Device by contacting your Sealey dealer. **You must also read and understand the following instructions concerning electrical safety.**

1.1.1. The **Electricity at Work Act 1989** requires all portable electrical appliances, if used on business premises, to be tested by a qualified electrician, using a Portable Appliance Tester (PAT), at least once a year.

1.1.2. The **Health & Safety at Work Act 1974** makes owners of electrical appliances responsible for the safe condition of those appliances and the safety of the appliance operators. **If in any doubt about electrical safety, contact a qualified electrician.**

1.1.3. Ensure that the insulation on all cables and on the appliance is safe before connecting it to the power supply. See 1.1.1. and 1.1.2. and use a Portable Appliance Tester.

1.1.4. Ensure that cables are always protected against short circuit and overload.

1.1.5. Regularly inspect power supply cables and plugs for wear or damage and check all connections to ensure that none is loose.

1.1.6. **Important:** Ensure that the voltage marked on the appliance matches the power supply to be used and that the plug is fitted with the correct fuse - see fuse rating at right.

1.1.7. **DO NOT** pull or carry the appliance by the power cable.

1.1.8. **DO NOT** pull the plug from the socket by the cable.

1.1.9. **DO NOT** use worn or damaged cables, plugs or connectors. Immediately have any faulty item repaired or replaced by a qualified electrician. When an ASTA/BS approved UK 3 pin plug is damaged, cut the cable just above the plug and **dispose of the plug safely.** Fit a new plug according to the following instructions (UK only).

a) **Connect the GREEN/YELLOW earth wire to the earth terminal 'E'.**

b) **Connect the BROWN live wire to the live terminal 'L'.**

c) **Connect the BLUE neutral wire to the neutral terminal 'N'.**

d) **After wiring, check that there are no bare wires, that all wires have been correctly connected, that the cable outer insulation extends beyond the cable restraint and that the restraint is tight.**

Double insulated products, which are always marked with this symbol , are fitted with live (brown) and neutral (blue) wires only. To rewire, connect the wires as indicated above - **DO NOT** connect either wire to the earth terminal.

1.1.10. Products which require more than 13 amps are supplied without a plug. In this case you must contact a qualified electrician to ensure that a 30 amp supply is available. We recommend that you discuss the installation of an industrial round pin plug and socket with your electrician.

1.1.11. If an extension reel is used it should be fully unwound before connection. A reel with an RCD fitted is preferred since any appliance plugged into it will be protected. The section of the cores in the cable is important and should be at least 1.5mm², but to be absolutely sure that the capacity of the reel is suitable for this product and for others which may be used in the other output sockets, we recommend the use of 2.5mm² section cable.

1.2. GENERAL SAFETY INSTRUCTIONS

Familiarise yourself with the application and limitations of the compressor.
 Ensure that the compressor is in good order and condition before use. If in any doubt do not use. Contact an electrician/service agent.

WARNING! the compressor must be serviced by an authorised agent only. DO NOT tamper with, or attempt to adjust, the pressure switch or the safety valve.

Before moving, or maintaining the compressor ensure that it is unplugged from the mains supply and that the air tank pressure has been vented.

Only use recommended parts and accessories. To use unauthorised items may be dangerous and will invalidate your warranty.

Read the instructions regarding any accessory used with the compressor. Ensure that the safe working pressure of any air appliance used exceeds the output pressure of the compressor.

Ensure that the air supply valve is turned off before disconnecting the air supply hose.

Keep tools and other items away from the compressor when it is in use and keep the area clean and free of unrelated items.

Ensure that the air hose is not tangled, twisted or pinched.

Keep children and unauthorised persons away from the work area.

DO NOT dis-assemble compressor for any reason. The unit must be checked by qualified personnel only.

DO NOT use the compressor outdoors, or in damp, or wet, locations and **DO NOT** operate it within the vicinity of flammable liquids, gases or solids.

DO NOT touch compressor cylinder, cylinder head or pipe from head to tank as these may be hot and will remain so for some time after shutdown.

DO NOT attempt to move the compressor by pulling the air supply hose. Only move the compressor by the handle.

DO NOT attempt to lift or move the compressor by any means other than by the handle.

Use the compressor in a well ventilated area and ensure that it is placed on a firm, level surface.

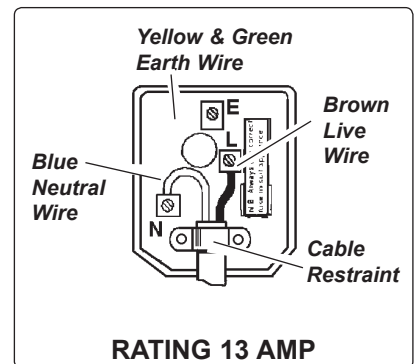

- X DO NOT use this product to perform a task for which it is not designed.
- X DO NOT deface the certification plate attached to the compressor tank.
- X DO NOT cover the compressor or restrict air flow around the machine whilst operating.
- ▲ **DANGER! DO NOT direct the output jet of air towards people or animals.**
- X DO NOT operate the compressor without an air filter.
- X DO NOT allow anyone to operate the compressor unless they have received full instructions.
- ☐ **WARNING! The air tank is a pressure vessel and the following safety measures apply:**
- X DO NOT tamper with the safety valve and DO NOT modify or alter the tank in any way and DO NOT strap anything to the tank.
- X DO NOT subject the tank to impact, vibration or to heat and DO NOT allow contact with abrasive or corrosive materials.
- ✓ DO drain condensation from tank daily and inspect inside walls for corrosion every three months. Have a detailed tank inspection carried out annually. The tank shell must not fall below the certified thickness at any point.
- ☐ **WARNING! If an electrical fuse blows, ensure that it is replaced with one of identical type and rating.**
- ✓ When not in use, disconnect from the mains, vent the tank and store the compressor in a safe, dry, childproof location.

2. INTRODUCTION & SPECIFICATION

Compact and portable, this compressor is suitable for use with the Sealey range of air nailers and air brushes and is fitted with twin gauges to display both the tank pressure and the working pressure. Fitted with 4 anti-vibration suction feet for added stability when in use. Complies fully with current European standards.

| | |
|---------------------------|-----------------|
| MODEL | SA2306 |
| Motor output | 1hp |
| Voltage/phase | 230V/1 |
| Current | 3.5A |
| Pump type | Single cylinder |
| Piston displacement | 4.5cfm |

| | |
|--|-------------------|
| Free air delivery | 4cfm |
| Tank capacity | 6ltr |
| Max pressure | 115psi / 8bar |
| Noise level | 78dB.A |
| Weight | 15.85kg |
| Dimensions - Length x width x height | 460 x 175 x 420mm |

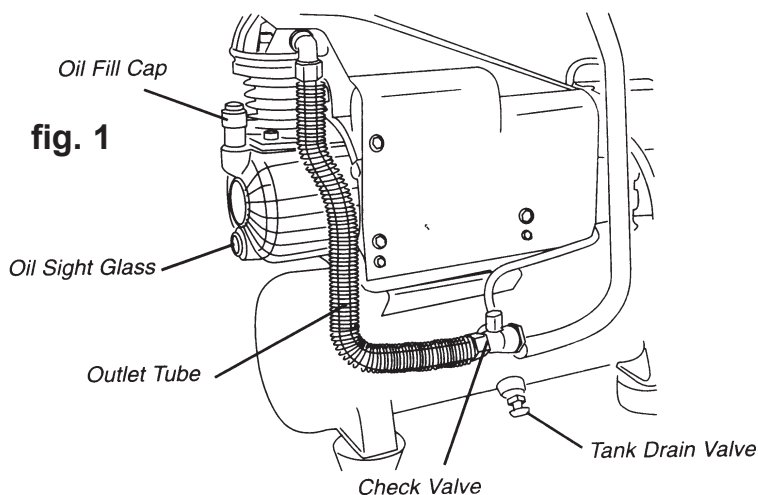
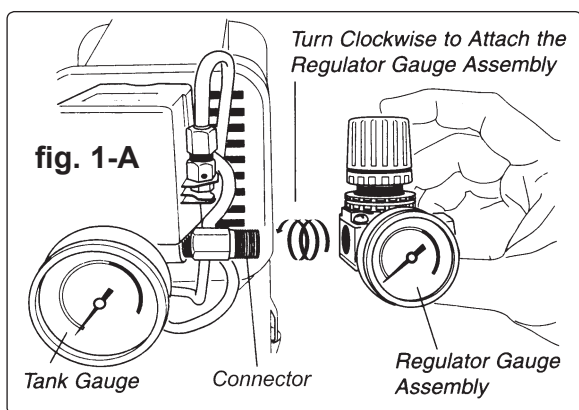

3. PREPARATION & ASSEMBLY

- ☐ **WARNING! The compressor is supplied without any lubricating oil in the pump - see para. 3.4.**
- 3.1. Remove compressor from packaging and inspect for any shortages or damage. If anything is found to be missing or damaged contact your supplier.
- 3.2. Confirm that the mains voltage corresponds with the voltage shown on the compressor data plate.
- 3.3. The compressor should be installed on a flat surface, or one that does not exceed 15° either transversely or longitudinally, and should be in a position that allows good air circulation around the unit.
- 3.4. **IMPORTANT! Remove the oil filler/breather from the pump (fig.2-A) and add the oil provided until the level is up to the centre of sight glass (fig. 2-B). Replace the filler/breather. DO NOT ATTEMPT TO RUN THE COMPRESSOR UNTIL THIS HAS BEEN DONE.**
- 3.5. Ensure that the air vent in the oil filler/breather is free from debris. If the air vent is blocked, pressure can build up in the crankcase causing damage to the compressor and possible personal injury.
- 3.6. Screw air filter (fig.3.C) into inlet port.
- 3.7. **Regulator assembly.** (See fig.1-A) Remove any packing material from the connector attached to the pressure switch. Check that the connector thread has a factory applied sealant to prevent leaks. Thread the regulator assembly onto the connector making sure that it is properly aligned to avoid cross threading. The assembly should rotate approximately 6 to 7 revolutions. The two gauges should be facing in the same direction. Do not overtighten.

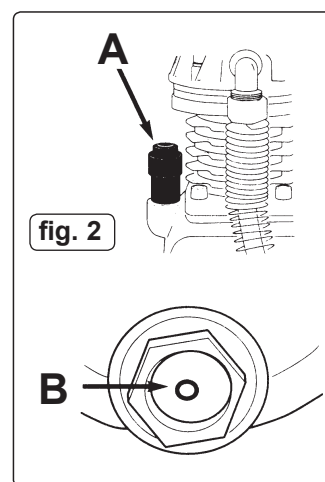

4. TOOL SELECTION

- ☐ **IMPORTANT**
- Take care when selecting tools for use with the compressor. Air tool manufacturers normally express the volume of air required to operate a tool in cubic feet per minute (cfm). This refers to free air delivered by the compressor ('air out') which varies according to the pressure setting. Do not confuse this with the compressor displacement which is the air taken in by the compressor ('air in'). 'Air out' is always less than 'air in' - due to losses within the compressor - and so it is important that, before choosing equipment, you study the 'Free Air Delivery' figures shown in the Specification Chart above.

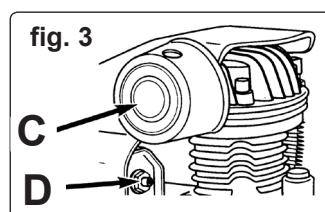

5. OPERATION

- ❑ **WARNING! ENSURE THAT YOU HAVE READ, UNDERSTOOD AND APPLIED SECTION 1 SAFETY INSTRUCTIONS.**

- 5.0 **DUTY CYCLE:** This is a 50% duty cycle air compressor. Do not run the air compressor for more than 30 minutes in any one hour. Doing so could damage the air compressor.
- 5.1 Make sure that the main switch (fig.4.1) is 'Off' (down).
- 5.2 Check the oil level by looking through the sight glass (See fig.2-B)
- 5.3 Ensure that the tank drain valve is closed. (See fig.1)
- 5.4 Close the air outlet tap so that its position is as shown in fig.4-3.
- 5.5 Close the outlet pressure regulator by turning the knob clockwise (See fig.4-2)
- 5.6 Connect the air tool required to the compressor via an air line connected to the air outlet (See fig.4-4)
- 5.7 Plug the mains cable into the mains supply and start the compressor by pulling up the main switch.
- 5.8 Allow the pressure in the tank to rise to the maximum at which point the compressor will automatically cut out. Tank pressure is shown on the larger gauge (fig.4.6).
- 5.9 Fully open the air outlet valve by turning it through 180°.
- 5.10 Begin to gradually open the regulator by turning the knob anticlockwise until the small gauge registers the required operating pressure specified for the tool to be used. Always **adjust up** to the required pressure rather than down from a higher pressure. The required setting, once achieved, can be locked by screwing the locking ring (See fig.4-2A) up tight underneath the adjusting knob.
- 5.11 You can now begin to use the tool. The compressor will operate automatically cutting in and out as required to restore the air pressure in the tank. The pressure switch (fig.4-8) stops the motor when the maximum tank pressure is reached and restarts it when pressure falls below the minimum threshold - approx. 2 bar (29psi) less than the maximum pressure.

- Note:** a) If the motor does not cut in and out, but runs continuously when using an air appliance, the capacity of the compressor may be too small for the appliance.
- b) The main gauge (fig.4.6) indicates the pressure inside the main tank, **NOT** the pressure supplied to the air equipment, which is shown on the smaller gauge (fig.4.5). Should the pressure in the main tank exceed the pre-set switch (fig.4.8) maximum, a safety valve (fig.4.7) will activate. **WARNING! For this reason DO NOT tamper with, or adjust, the switch or the safety valve.** (When the compressor is not being used set the regulated pressure to zero so as to avoid damaging the pressure regulator.)
- 5.12 To stop the compressor press down the main switch (fig.4.1). When the compressor stops there will be a whistling sound as compressed air is vented from the compressor head. **DO NOT**, other than in an emergency, stop the compressor by switching off the mains socket, or by pulling the plug out, as the pressure relief will not then occur and motor damage may result upon restart.

- 5.13 When you have finished using the compressor unplug the unit from the mains power supply.
- 5.14 Set the outlet pressure on the regulator to zero.
- 5.15 Close the air outlet tap and remove the air line and air tool.
- 5.16 The tank must now be drained. This will release the air left in the tank and drain away condensation that may have formed within the tank. Choose a suitable location for this operation and/or make provision to collect the condensation. **Wear ear and eye protection.** Open the tank drain valve (See fig.1) slowly allowing air and moisture to bleed from the tank. After bleeding close the drain valve to prevent debris building up in the valve.

- ❑ **WARNING! Water that is allowed to remain in the tank during storage will corrode and weaken the air tank which could cause the tank to rupture. To avoid serious injury drain the tank after each use or daily.**

5.17 SAFETY FEATURES

Thermal cut out: If the unit overheats the thermal cut out will operate and shut the unit down. The thermal cut out will automatically reset when the unit has cooled down which may take up to 30 minutes.

Current overload trip: See fig.3D. If this trip operates, investigate and remedy the problem before manually resetting the trip by pushing in the button.

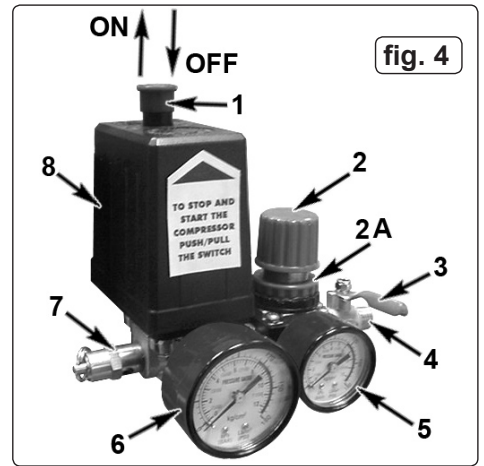

6. MAINTENANCE

- ❑ **WARNING!** Before performing any maintenance operation, switch off the compressor, disconnect from electricity supply and release all air from the tank. In order to keep the compressor in good working condition, periodical maintenance is essential.
- 6.1. **After the first 10 working hours replace the lubricating oil - see para 6.3.**
- 6.2. **OPERATIONS TO BE CARRIED OUT DAILY:**
- a) Drain condensation by opening the valve located under the tank. Place a container under the valve and open the valve by turning anti-clockwise.
 - b) Check the condition of the air filter. If necessary remove the filter element (fig.3 A) and clean by blowing through, with an air line at low pressure, from the clean side or wash in soapy water, rinse and dry. Do not operate the compressor without the filter as foreign bodies or dust could seriously damage the pump.
 - c) Check for oil leaks
 - d) Check oil level and, if necessary, top up.
- 6.3. **OPERATIONS TO BE CARRIED OUT EVERY 100 HOURS** (or more frequently, if the compressor operates in a very dusty atmosphere):
- a) Check the automatic cut-out at max. pressure and the automatic cut-in at 2 bar below.
 - b) Replace the lubricating oil. For oil specifications see below.
Remove the oil filler plug 'A' and unscrew sight glass 'B', draining the oil into a container. Drain when the compressor is hot so that oil drains rapidly and completely. Incline compressor to ensure complete drainage.
Replace sight glass and refill through the filler aperture. Do not overfill. Replace plug 'A'.
- Recommended oil for compressors,
Suitable for room temperatures ranging from +50C to +250C. SEALEY CPO or equivalent SAE 40 compressor oil.
Room temperature below +50C: SAE 20 compressor oil.
- ❑ **WARNING! Never mix different oils and do not use non-detergent/low quality oils as the compressor may be damaged. Dispose of waste oil only in accordance with local authority requirements.**
- 6.4. **OPERATIONS TO BE CARRIED OUT EVERY 500 HOURS:**
- a) Replace air filter.
 - b) Check all tube fittings and electrical connections.
 - c) Inspect pressure tank inside and out for damage or corrosion.
- IMPORTANT! Failure to carry out maintenance tasks may invalidate the warranty on your compressor.**

6. TROUBLESHOOTING

| FAULT | CAUSE | REMEDY |
|--|--|--|
| 1A) Pressure drop in the tank | Air leaks at connections | Run compressor to max. pressure, switch off. Brush soap solution over connections and look for bubbles. Tighten connections showing leaks. If problem persists contact Authorised Service Agent. |
| 1B) Pressure drop in the tank | Air leaks from safety valve | Operate the safety valve manually by pulling on the ring. If valve continues to leak when in the closed position it should be replaced |
| 1C) Pressure drop in the tank | Air leaks from cylinder head gasket | Check tightness of head bolts. If leak continues contact authorised service agent. |
| 2) Pressure switch valve leaks when compressor is idle | Non-return valve seal defective | Empty the air tank, remove the non-return valve cap and clean, or if necessary replace the seal. |
| 3) Air leaks from tank body or tank welds | Internal corrosion caused by infrequent tank draining or non permitted modifications to tank | Tank could rupture or explode. Cannot be repaired. DISCONTINUE USE IMMEDIATELY |
| 4A) Motor stops and will not restart | Thermal cut out has operated | Allow unit to cool for 30 minutes before restarting |
| 4B) Motor stops and will not restart | Supply fuse has tripped | Reset fuse and restart unit. If repeated tripping occurs replace the check valve or contact authorised service agent |
| 4C) Motor stops and will not restart | Current overload trip has operated | Investigate and remedy reason for overload. Reset by pushing button back in (See fig.3D) |
| 5) Compressor stops and does not restart | Motor failure | Contact Authorised Service Agent. |
| 6A) Compressor does not stop at max. pressure | Pressure switch fault | Contact Authorised Service Agent. |
| 6B) Compressor does not stop at max. pressure | Filter clogged Head gasket or valve fault | Replace filter element. Contact Authorised Service Agent. |
| 7) Compressor noisy with metallic knock | Bearing or piston damage | Contact Authorised Service Agent. |
| 8) Excessive moisture in discharged air | High humidity environment | Drain tank after each use |

NOTE: It is our policy to continually improve products and as such we reserve the right to alter data, specifications and component parts without prior notice.

IMPORTANT: No liability is accepted for incorrect use of this product.

WARRANTY: Guarantee is 12 months from purchase date, proof of which will be required for any claim.

INFORMATION: For a copy of our latest catalogue and promotions call us on 01284 757525 and leave your full name and address, including postcode.



Sole UK Distributor, Sealey Group,
Kempson Way, Suffolk Business Park,
Bury St. Edmunds, Suffolk,
IP32 7AR



01284 757500



www.sealey.co.uk



01284 703534



sales@sealey.co.uk