

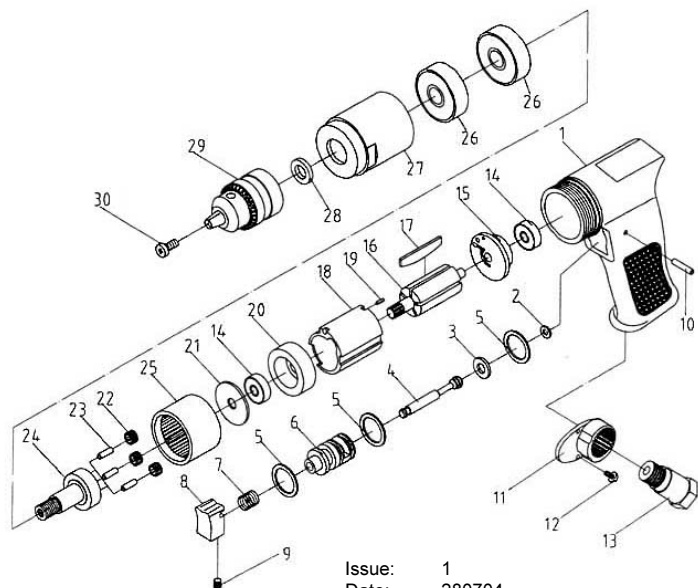

PARTS LIST FOR:

10mm AIR DRILL

Model: SA23/S.V3

Issue: 1  
Date: 280704

Item	Part No.	Description	Item	Part No.	Description
1	SA23S.V3-01	Housing	17	SA23S.V3-17	Rotor blade
2	SA23S.V3-02	O-ring	18	SA23S.V3-18	Cylinder
3	SA23S.V3-03	O-ring	19	SA23S.V3-19	Pin
4	SA23S.V3-04	Valve stem	20	SA23S.V3-20	Front plate
5	SA23S.V3-05	O-ring	21	SA23S.V3-21	Washer
6	SA23S.V3-06	Bushing	22	SA23S.V3-22	Gear
7	SA23S.V3-07	Trigger spring	23	SA23S.V3-23	Pin
8	SA23S.V3-08	Trigger	24	SA23S.V3-24	Work spindle
9	SA23S.V3-09	Trigger screw	25	SA23S.V3-25	Thread ring gear
10	SA23S.V3-10	Pin	26	SA23S.V3-26	Bearing
11	SA23S.V3-11	Muffle cover	27	SA23S.V3-27	Clamp nut
12	SA23S.V3-12	Screw	28	SA23S.V3-28	Washer
13	SA23S.V3-13	Air inlet	29	SA23S.V3-29	Use DC/J-38 CHUCK 10mm
14	SA23S.V3-14	Bearing	30	SA23S.V3-30	Chuck screw
16	SA23S.V3-16	Rotor			

**NOTE:** It is our policy to continually improve products and as such we reserve the right to alter data, specifications and component parts without prior notice.

**IMPORTANT:** No liability is accepted for incorrect use of this equipment.

**WARRANTY:** Guarantee is 12 months from purchase date, proof of which will be required for any claim.

**INFORMATION:** For a copy of our latest catalogue and promotions call us on 01284 757525 and leave your full name and address, including postcode.

**SEALEY POWER TOOLS** Sole UK Distributor,  
Sealey Group, Bury St. Edmunds, Suffolk.

01284 757500

01284 703534

sales@sealey.co.uk

www.sealey.co.uk



INSTRUCTIONS FOR:

10mm AIR DRILL

Model: SA23/S.V3

Thank you for purchasing a Sealey Product. Manufactured to a high standard this product will, if used according to these instructions and properly maintained, give you years of trouble free performance.



**IMPORTANT:** PLEASE READ THESE INSTRUCTIONS CAREFULLY. NOTE THE SAFE OPERATIONAL REQUIREMENTS, WARNINGS AND CAUTIONS. USE THIS PRODUCT CORRECTLY AND WITH CARE FOR THE PURPOSE FOR WHICH IT IS INTENDED. FAILURE TO DO SO MAY CAUSE DAMAGE AND/OR PERSONAL INJURY AND WILL INVALIDATE THE WARRANTY. PLEASE KEEP INSTRUCTIONS SAFE FOR FUTURE USE.

## 1. SAFETY INSTRUCTIONS

- WARNING!** Ensure Health & Safety, local authority, and general workshop practice regulations are adhered to when using this equipment.
- WARNING!** Disconnect from air supply before changing drill bits, or servicing, or performing any maintenance.
- ✓ Maintain the drill in good condition (use an authorised service agent).
- ✓ Replace or repair damaged parts. Use genuine parts only. Unauthorised parts may be dangerous and will invalidate the warranty.
- ✓ Use in a suitable work area. Keep area free from unrelated materials and ensure that there is adequate lighting.
- ✓ Before each use check condition of drill bit. Sharpen if necessary. If worn or damaged replace immediately.
- ✓ Ensure the speed rating (rpm) of the drill bit is the same as, or greater than, the speed rating of the drill.
- ✓ Ensure there are no flammable or combustible materials near the work area.
- ✓ Evaluate your working area before using the drill. Ceilings, floors and enclosures may contain hidden electrical wiring, water pipes or gas pipes.
- WARNING!** Always wear approved eye (or face) and hand protection when operating the drill.
- ✓ Use face, dust, or respiratory protection in accordance with COSHH regulations.
- ✓ Depending on the task, the drilling noise level may exceed 84dB in which case wear safety ear defenders.
- ✓ Remove ill fitting clothing. Remove ties, watches, rings, other loose jewellery and contain and/or tie back long hair.
- ✓ Wear appropriate protective clothing and keep hands and body clear of working parts.
- ✓ Maintain correct balance and footing. Do not over reach, ensure the floor is not slippery, wear non-slip shoes.
- ✓ Keep children and unauthorised persons away from the working area.
- ✓ Check moving parts alignment on a regular basis.
- ✓ Ensure workpiece is secure before operating the drill. Never hold a workpiece by hand.
- ✓ Check the workpiece to ensure there are no protruding screws, bolts, nuts etc.
- ✓ Avoid unintentional starting.
- ✓ Remove chuck key before starting the drill.
- WARNING!** Ensure correct air pressure is maintained and not exceeded. Recommended pressure 70-90psi
- ✓ Keep air hose away from heat, oil and sharp edges. Check air hose for wear before each use and ensure that all connections are secure.
- ✓ Prolonged exposure to vibration from this drill poses a health risk. It is the owner's responsibility to correctly assess the potential hazard and issue guidelines for safe periods of use and offer suitable protective equipment.
- x **DO NOT** use the drill for a task it is not designed to perform.
- x **DO NOT** operate drill if any parts are damaged or missing as this may cause failure and/or personal injury.
- WARNING!** **DO NOT** drill any materials containing asbestos.
- x **DO NOT** carry the drill by the hose, or yank the hose from the air supply.
- x **DO NOT** force, or apply heavy pressure to the drill; let the tool do the work.
- x **DO NOT** place air line attachments close to your face and do not point at other people or animals.
- x **DO NOT** operate drill when you are tired or under the influence of alcohol, drugs or intoxicating medication.
- x **DO NOT** use drill where there are flammable liquids, solids or gases such as paint solvents and including waste wiping or cleaning rags etc.
- x **DO NOT** carry the drill with your finger on the trigger.
- x **DO NOT** direct air from the air line at yourself or others.
- ✓ When not in use disconnect from air supply and store in a safe, dry, childproof location.

## 2. INTRODUCTION & SPECIFICATION

The SA23/S.V3 is suitable for general workshop use and has a polished and well balanced aluminium body with precision planetary gears giving quiet and smooth operation. Fitted with 10mm drill chuck and supplied with a chuck key.

Free Speed .....2200rpm  
 Operating Pressure .....90psi  
 Air Consumption .....4cfm  
 Air Inlet .....1/4" BSP

Sound Pressure .....81dB(A)  
 Vibration .....1.3m/s<sup>2</sup>  
 Weight .....1.11kg  
 Chuck Size .....10mm

## 3. PREPARING DRILL FOR USE

### 3.1. Air Supply

**WARNING!** Ensure the air supply is clean and does not exceed 90 psi while operating the drill. Too high an air pressure and unclean air will cause excessive wear, and may be dangerous, causing damage and/or personal injury.

- 3.1.1. Ensure the drill air valve (or trigger) is not depressed before connecting to the air supply.
- 3.1.2. You will require an air pressure between 70-90psi, and an air flow according to the specification above.
- 3.1.3. Drain the air tank daily. Water in the air line will damage the drill and invalidate your warranty.
- 3.1.4. Clean air inlet filter weekly. Recommended hook-up procedure is shown in fig 1.
- 3.1.5. Line pressure should be increased to compensate for unusually long air hoses (over 8 metres). The minimum hose diameter should be 1/4" I.D. and fittings must have the same inside dimensions.
- 3.1.6. Keep hose away from heat, oil and sharp edges. Check hoses for wear, and make certain that all connections are secure.

### 3.2. Couplings

Vibration may cause failure if a quick change coupling is connected directly to the air drill. To overcome this, connect a leader hose - Sealey model number AH2R or AH2R/38 - to the drill. A quick change coupling may then be used to connect the leader hose to the air line recoil hose. See figs. 1 & 2.

fig. 1

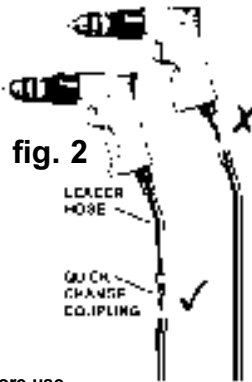
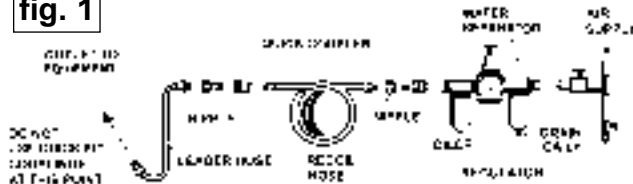

## 4. OPERATING INSTRUCTIONS

**WARNING!** Ensure you read, understand and apply safety instructions before use.

**4.1. DRILL BIT FITTING.** Regularly check the drill bit and always change if worn, cracked or otherwise damaged.

**WARNING! Unplug from the air supply before placing bit into chuck.**

- 4.1.1. Open or close the chuck jaws to a point where the opening is slightly larger than the drill or tool bit (fig 3 A) to be used. Also raise the front of the drill slightly to prevent bit from falling out of the chuck jaws. Insert the drill bit into the chuck as far as it will go. Place the chuck key in one of the chuck holes and tighten the chuck securely.

**WARNING! Ensure you remove the chuck key before starting the drill.**

- 4.2. Connect air supply to drill. Squeeze the trigger to check that the drill is working correctly before starting work.
  - 4.2.1 **DO NOT** allow drill to run freely for an extended period of time as this will shorten the life of bearings.

### 4.3. STANDARD DRILLING INSTRUCTIONS.

**WARNING! Ensure you wear approved safety goggles and any other safety item required for the job. Remove the chuck key before using the drill. Also ensure that all other safety requirements are followed.**

fig 3



- 4.3.1. Connect drill to air supply.
- 4.3.2. Hold tool firmly and place the bit tip to the point to be drilled.
- 4.3.3. Depress the trigger to start drill. Move the drill bit into the work piece applying only enough pressure to keep the bit cutting. **DO NOT** force or apply side pressure to elongate the hole.
- 4.3.4. If the material to be drilled is free standing it should be secured in a vice or with clamps to keep it from turning as the drill bit rotates.
- 4.3.5. When drilling metals, use a light oil on the drill bit to keep it from overheating. Oil will prolong life of bit and improve the drilling action.
- 4.3.6. For hard smooth surfaces use a centre punch to mark desired hole location. This will prevent bit from slipping as your start to drill.
- 4.3.7. A pilot hole may be necessary to assist the final drill size through the work piece. Lock a pilot drill (smaller size drill than the finished hole size) into the chuck. Follow steps 4.3.1. to 4.3.3. above and drill a pilot hole in the middle of the centre punch mark where final hole is to be drilled. Insert the final sized bit in chuck. Hold drill firmly and place the bit at the entrance of the pilot hole and depress the trigger.

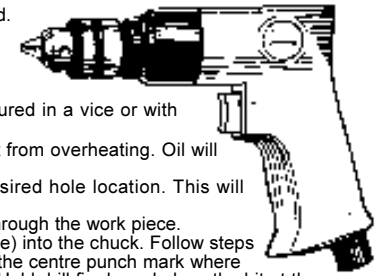

**WARNING! Be prepared for drill binding or break through. When these situations occur the drill has a tendency to grab and kick in the opposite direction which could cause loss of control. If you are not prepared, this loss of control can result in damage and/or personal injury.**

- 4.3.8. If the bit jams in the workpiece or if the drill stalls, release the trigger switch immediately. Remove the bit from the workpiece and determine the reason for jamming.

## 5. MAINTENANCE

**WARNING! Disconnect drill from air supply before changing drill bit, servicing or performing maintenance.** Replace or repair damaged parts. Use genuine parts only. Unauthorised parts may be dangerous and will invalidate the warranty.

- 5.1. Lubricate the drill daily with a few drops of good grade air tool oil, such as Sealey ATO/500 or ATO/1000, dripped into the air inlet before use or dispensed automatically through an air system oiler, such as Sealey model SA100L or SA1/L.
- 5.2. Clean the drill after use and change the bit when worn or damaged.
- 5.3. Loss of power or erratic action may be due to the following:
  - a) Excessive drain on the air supply. Moisture or restriction in the air line. Incorrect size or type of hose connectors. To remedy check the air supply and follow instructions in Section 3.
  - b) Grit or gum deposits in the drill may also reduce performance. Flush the drill with gum solvent oil or an equal mixture of SAE No 10 oil and kerosene. Allow to dry before use.
 If you continue to experience problems, contact your local Sealey service agent.
- 5.4. For a full service contact your local Sealey service agent.

### Risk of Hand Arm Vibration Injury

10mm Reversible Air Drill model no. SA23/S.V3 when operated in accordance with these instructions and tested in accordance with EN 28662-2: 1994 results in the following vibration emission declared in accordance with BS EN12096: 1996.

Measured vibration emission value: .....1.3m/s<sup>2</sup>  
 Uncertainty: .....0.52m/s<sup>2</sup>

**These values are suitable for comparison with emission levels of other tools that have been subject to the same test.**

**This tool may cause hand-arm vibration syndrome if its use is inadequately managed.**

### Recommended L.C. Measures to reduce risk of hand-arm vibration syndrome:

This item represents a low Hand Arm Vibration risk to users. The calculated minimum usage period exceeds 8 hours. We recommend appropriate safety equipment is utilised and regular breaks for the operator are employed to reduce any residual risk of fatigue or repetitive strain injury.

### Declaration of Conformity

**CE** We, the sole importer into the UK, declare that the product listed here is in conformity with the following standards and directives. The construction file for this product is held by the Manufacturer and may be inspected, by a national authority, upon request to Jack Sealey Ltd.

Signed by Mark Sweetman

**10mm AIR DRILL  
 Model: SA23/S.V3**

98/37/EC Machinery Directive  
 93/68/EEC Marking Directive

28th July 2004

For Jack Sealey Ltd. Sole importer into the UK of Sealey Power Tools.