

Thank you for purchasing a Sealey product. Manufactured to a high standard this product will, if used according to these instructions and properly maintained, give you years of trouble free performance.



1. SAFETY INSTRUCTIONS

1.1 ELECTRICAL SAFETY

- ☐ **WARNING!** It is the responsibility of the owner and the operator to read, understand and comply with the following:
 - You must check all electrical products, before use, to ensure that they are safe. You must inspect power cables, plugs, sockets and any other connectors for wear or damage. You must ensure that the risk of electric shock is minimised by the installation of appropriate safety devices. A Residual Current Circuit Breaker (RCCB) should be incorporated in the main distribution board. We also recommend that a Residual Current Device (RCD) is used. It is particularly important to use an RCD with portable products that are plugged into a supply which is not protected by an RCCB. If in any doubt consult a qualified electrician. You may obtain a Residual Current Device by contacting your Sealey dealer.
 - You must also read and understand the following instructions concerning electrical safety.
- 1.1.1 The Electricity at Work Act 1989 requires that all portable electrical appliances, if used on business premises, are tested by a qualified electrician, using a Portable Appliance Tester (PAT), at least once a year.
- 1.1.2 The Health & Safety at Work Act 1974 makes owners of electrical appliances responsible for the safe condition of those appliances and the safety of the appliance operators. If in any doubt about electrical safety, contact a qualified electrician.
- 1.1.3 Ensure that the insulation on all cables and on the appliance is safe before connecting it to the power supply. See 1.1.1 and 1.1.2 and use a Portable Appliance Tester.
- 1.1.4 Ensure that cables are always protected against short circuit and overload.
- 1.1.5 Regularly inspect power supply cables and plugs for wear or damage and check all connections to ensure that none are loose.
- 1.1.6 Important: Ensure that the voltage marked on the appliance matches the power supply to be used and that the plug is fitted with the correct fuse - see fuse rating at right.
- 1.1.7 DO NOT pull or carry the appliance by the power cable.
- 1.1.8 DO NOT pull the plug from the socket by the cable.
- 1.1.9 DO NOT use worn or damaged cables, plugs or connectors. Immediately have any faulty item repaired or replaced by a qualified electrician. When a BS 1363/A UK 3 pin plug is damaged, cut the cable just above the plug and dispose of the plug safely.
 - Fit a new plug according to the following instructions (UK only).
 - a) **Connect the GREEN/YELLOW earth wire to the earth terminal 'E'.**
 - b) **Connect the BROWN live wire to the live terminal 'L'.**
 - c) **Connect the BLUE neutral wire to the neutral terminal 'N'.**
 - d) After wiring, check that there are no bare wires, that all wires have been correctly connected, that the cable outer insulation extends beyond the cable restraint and that the restraint is tight. Double insulated products, which are always marked with this symbol , are fitted with live (brown) and neutral (blue) wires only. To rewire, connect the wires as indicated above - DO NOT connect either wire to the earth terminal.
- 1.1.10 Products which require more than 13 amps are supplied without a plug. In this case you must contact a qualified electrician to ensure that a suitably rated supply is available. We recommend that you discuss the installation of an industrial round pin plug and socket with your electrician.
- 1.1.11 If an extension reel is used it should be fully unwound before connection. A reel with an RCD fitted is preferred since any appliance plugged into it will be protected. The cable core section is important and should be at least 1.5mm², but to be absolutely sure that the capacity of the reel is suitable for this product and for others which may be used in the other output sockets, we recommend the use of 2.5mm² section cable.

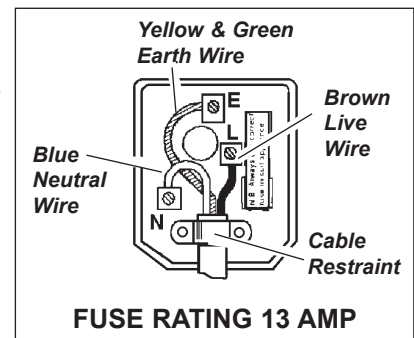

1.2 GENERAL SAFETY INSTRUCTIONS

- ✓ Familiarise yourself with the application and limitations of the compressor.
- ✓ Ensure the compressor is in good order and condition before use. If in any doubt do not use the unit and contact an electrician/service agent.
- ☐ **WARNING! Compressor must only be serviced by an authorised agent. DO NOT tamper with, or attempt to adjust, pressure switch or safety valve.**
- ☐ Before moving, or maintaining the compressor ensure it is unplugged from the mains supply and that the air tank pressure has been vented.
- ✓ Only use recommended attachments and parts. To use unapproved items may be dangerous and will invalidate your warranty.
- ✓ Read the instructions regarding any accessory used with the compressor. Ensure the safe working pressure of any air appliance used exceeds unit's output pressure. If using spray gun, check that the area selected for spraying is provided with air change system/ventilation.
- ✓ Ensure the air supply valve is turned off before disconnecting the air supply hose.
- ☐ To move the compressor use the handle only. Lift the compressor so that the front leg gives enough clearance for manoeuvring but maintain unit's centre of gravity in front of the wheels.
- ✗ DO NOT attempt to lift or move the compressor by any means other than by the handle.
- ✓ Use the compressor in a well ventilated area and ensure it is placed on a firm surface.
- ✓ Keep tools and other items away from the compressor when it is in use, and keep area clean and clear of unnecessary items.
- ✓ Ensure the air hose is not tangled, twisted or pinched.
- ✓ Keep children and unauthorised persons away from the working area.
- ✗ DO NOT dis-assemble compressor for any reason. The unit must be checked by qualified personnel only.
- ✗ DO NOT use the compressor outdoors, or in damp, or wet, locations and DO NOT operate within the vicinity of flammable liquids, gases or solids.

- x **DO NOT** touch compressor cylinder, cylinder head or pipe from head to tank as these may be hot and will remain so for some time after shutdown.
- x **DO NOT** attempt to move the compressor by pulling the air tool hose. Only move the compressor by the handle.
- x **DO NOT** use this product to perform a task for which it is not designed.
- x **DO NOT** deface the certification plate attached to the compressor tank.
- x **DO NOT** cover the compressor or restrict air flow around the machine whilst operating.
- ▲ **DANGER! DO NOT direct the output jet of air towards people or animals.**
- x **DO NOT** operate the compressor without an air filter.
- x **DO NOT** allow anyone to operate the compressor unless they have received full instructions.
- **WARNING! The air tank is a pressure vessel and the following safety measures apply:**
- x **DO NOT tamper with the safety valve and DO NOT modify or alter the tank in any way and DO NOT strap anything to the tank.**
- x **DO NOT subject the tank to impact, vibration or to heat and DO NOT allow contact with abrasives or corrosives.**
- ✓ **DO drain condensation from tank daily and inspect inside walls for corrosion every three months and have a detailed tank inspection carried out annually.**
- **The tank shell must not fall below the certified thickness at any point.**
- **WARNING! If an electrical fuse blows, ensure it is replaced with an identical fuse type and rating.**
- ✓ When not in use, store the compressor carefully in a safe, dry, childproof location.



2. INTRODUCTION & SPECIFICATION

Aluminium cylinder head with cast iron cylinder gives added resistance to wear. Suitable for general-purpose workshop applications. Pump head directly coupled to heavy-duty induction motor for reliable and quiet operation. Welded tank complies with latest European standards. Fitted with fully automatic pressure cut-out switch with twin gauges displaying tank and working pressures. Fitted with ASTA/BS approved non-rewirable plug.

Motor Output:	2.0hp	Tank Capacity:	50ltr
Voltage/Phase:	230V – 1ph	Maximum Pressure:	116psi/8bar
Input Current:	8.5A	Noise Power	93.3dBA
Piston Displacement:	8.3cfm	Noise Pressure	73.3dBA
Maximum Free Air Delivery:	7.0cfm		

3. PREPARATION

- 3.1 Remove compressor from packaging and inspect for any shortages or damage. If anything is found to be missing or damaged contact your supplier.
- 3.2 Save the packing material for future transportation of the compressor. We recommend that you store the packing in a safe location, at least for the period of the guarantee. Then, if necessary, it will be easier to send the compressor to the service centre.
- 3.3 Confirm that the mains voltage corresponds with the voltage shown on the compressor data plate.
- 3.4 The compressor should be operated on a flat surface, or one that does not exceed 15° either transversely or longitudinally (fig 1), and should be in a position that allows good air circulation around the unit.
- **WARNING! The compressor is shipped without oil in the pump. Do not start the compressor until it has been filled with oil (see below).**
- 3.5 Remove the plastic transit plug from the oil filler hole and pour in the recommended oil. (See section 5.6).
- 3.6 Before using the compressor check the oil level by referring to the oil sight glass (fig 2.C). If the oil level is not up to the red centre mark it should be further topped up. Screw the filler/breather cap into the aperture as shown in fig 2.B.

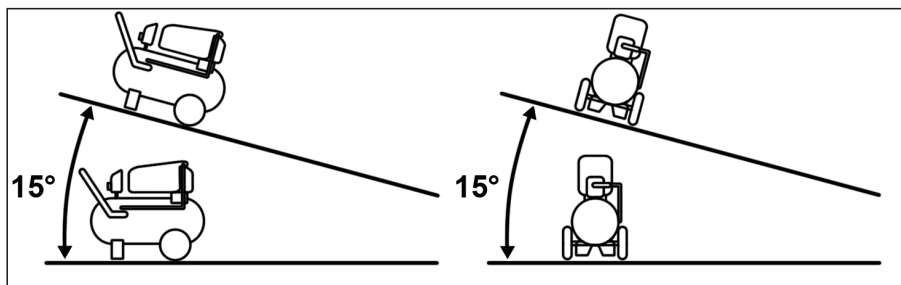

fig 1

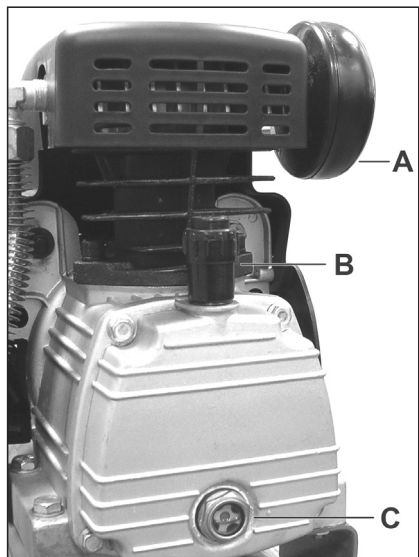

fig 2

4. OPERATION

- **WARNING!** Ensure that you have read, understood and apply Section 1 safety instructions.
IMPORTANT! The use of extension leads to connect this compressor to the mains is not recommended as the resulting voltage drop reduces motor, and therefore pump, performance.
- 4.1 Take care when selecting tools for use with the compressor. Air tool manufacturers normally express the volume of air required to operate a tool in cubic feet per minute (cfm). This refers to free air delivered by the compressor ('air out') which varies according to the pressure setting. Do not confuse this with the compressor displacement which is the air taken in by the compressor ('air in'). 'Air out' is always less than 'air in' - due to losses within the compressor .

4.2 STARTING THE COMPRESSOR

4.2.1 Your compressor is fitted with a push/pull type of ON/OFF switch.

To turn the compressor 'ON' pull the switch knob upwards. To turn the compressor 'OFF' push the knob downwards (fig 3.1).

4.2.2 Check that the ON/OFF switch is in the "OFF" position, the regulator tap (fig 3.3) is closed (Zero '0' bar), and tap (fig 3.5) is OFF.

4.2.3 Plug mains lead into mains supply and start the compressor by pulling the switch knob upwards.

4.2.4 When starting the compressor for the first time, leave it running with air outlet (fig 3.5) closed and regulator (fig 3.3) set to maximum pressure. Make sure that pressure in the tank rises and that the compressor stops automatically when the max. pressure value allowed - written on the specification plate and shown on the gauge (fig 3.7) - is achieved. The compressor will now operate automatically. The pressure switch (fig 3.2) stops the motor when the maximum tank pressure is reached and restarts it when pressure falls below the minimum threshold - approx. 2 bar (29psi) less than the maximum pressure.

4.2.5 Stop the compressor by pushing the switch knob (See fig 3.1) downwards. The compressed air inside the compressor head will flow out, making the restart easier and preventing the motor from being damaged. **DO NOT**, other than in an emergency, stop the compressor by switching off the mains socket, or by pulling the plug out, as the pressure relief will not then occur and motor damage may result upon restart. When the compressor runs correctly and is stopped correctly there will be:

(a) a whistle of compressed air when the motor stops,

(b) a protracted whistle (about 20-25 seconds) when the compressor starts with no pressure in the tank.

4.2.6 The output pressure is regulated by the pressure regulator (fig 3.3). Turn the knob clockwise to increase pressure and anticlockwise to reduce it. The knob can be locked at any required setting by tightening the locking ring (fig 3.4) up against the underside of the knob. To determine the correct working pressure for any piece of equipment check the corresponding manual. When the compressor is not being used, set the regulated pressure to zero so as to avoid damaging the pressure reducer.

NOTE: a) If the motor does not cut in and out, but runs continuously when using an air appliance, the capacity of the compressor may be too small for the equipment or tool.

b) The larger gauge (fig 3.7) indicates the pressure inside the main tank. The smaller gauge (fig 3.6) indicates the pressure supplied to the air equipment. Should the pressure in the main tank exceed the pre-set switch (fig 3.2) maximum, the safety valve (fig 3.8) will activate.

WARNING! For this reason DO NOT tamper with, or adjust, the switch or safety valve.

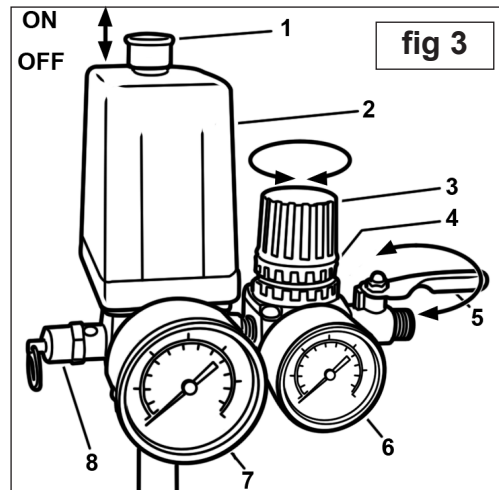

5. MAINTENANCE

In order to keep the compressor in good working condition, periodic maintenance is essential.

IMPORTANT! Failure to carry out maintenance tasks may invalidate the warranty on your compressor.

WARNING! Before performing any maintenance operation, switch off the compressor, disconnect from electricity supply and release all air from the tank.

5.1 Operations to be carried out **after the first 50 working hours:**

- Check that all bolts/nuts are tight, particularly those retaining the crank case and cylinder head.
- Replace the lubricating oil - see section 5.4.

5.2 Operations to be carried out daily:

- Drain condensation by opening the valve located under the tank (fig 5). Place a container under the valve and open the valve by turning anti-clockwise.

5.3 Operations to be carried out every 100 hours

(or more frequently, if the compressor operates in a very dusty atmosphere):

- Check oil level and, if necessary, top up.
- Remove the filter element (fig 4.A) and clean with compressed air. (Wear eye protection). Do not operate the compressor without the filter as foreign bodies or dust could seriously damage the pump.
- Check for oil leaks

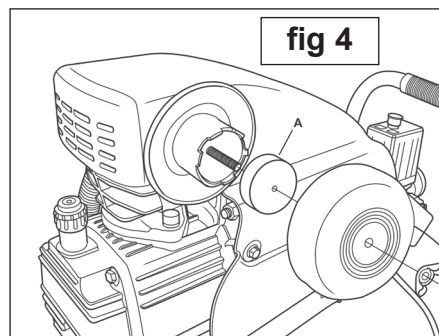

5.4 Operations to be carried out every 200 hours:

- Replace the lubricating oil. For oil specifications see 5.6. Remove the oil filler/breather plug (see fig 2.B) then unscrew oil sight glass (fig 2.C) and drain the oil into a container. Drain when the compressor is hot so that oil drains rapidly and completely. Incline compressor to ensure complete drainage. Replace oil sight glass and refill through the oil filler/breather aperture. Do not overfill. Replace filler/breather plug.
- Check the automatic cut-out at max. pressure and the automatic cut-in at 2 bar below.

WARNING! Never mix different oils and do not use non-detergent/low quality oils as the compressor may be damaged.

WARNING! Dispose of waste oil only in accordance with local authority requirements.

5.5 Operations to be carried out every 500 hours:

- Replace air filter. (See fig 4.A)
- Check all tube fittings and electrical connections.
- Inspect pressure tank inside and out for damage or corrosion.

5.6 Recommended oils

Recommended oil for compressors, suitable for room temperatures ranging from +5°C to +25°C. SEALEY CPO or equivalent SAE 40 compressor oil.

Room temperature below +5°C: SAE 20 compressor oil.

Approximate oil capacity: 0.16 litres.

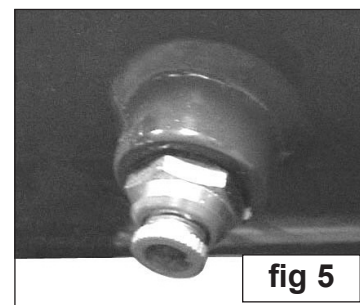

5.6 Scheduled maintenance table

Maintenance Operations	Daily	100 hrs	200 hrs	500 hrs
Drain condensation	•			
Check oil level		•		
Clean intake filter		•		
Check for oil leaks		•		
Check cut-out			•	
Replace oil			•	
General cleaning of compressor			•	
Internal & external inspection of tank				•
Replace air filter				•
Check tube fittings and electrical connections				•

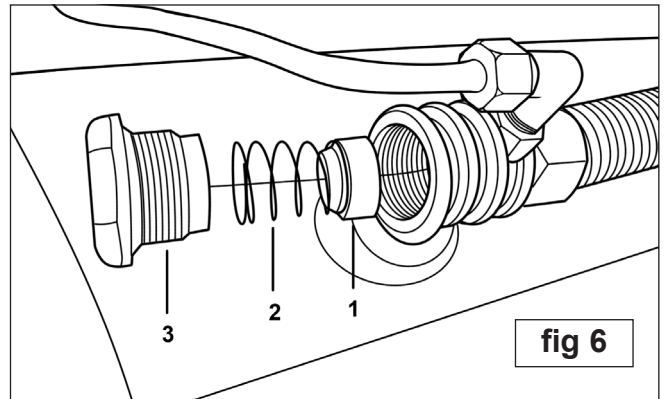



fig 6

6. TROUBLE SHOOTING

FAULT	CAUSE	REMEDY
Pressure drop in the tank.	Air leaks at connections.	Run compressor to max. pressure, switch off. Brush soap solution over connections and look for bubbles. Tighten connections showing leaks. If problem persists contact Authorised Service Agent.
Pressure switch valve leaks when compressor is idle.	Non-return valve seal defective.	Empty the air tank, remove the non-return valve cap '3' (fig 6) and clean, or if necessary replace, the seal '1'.
Compressor stops and does not restart.	Motor failure.	Contact Authorised Service Agent.
Compressor does not stop at max. pressure.	Pressure switch fault.	Contact Authorised Service Agent.
Compressor does not stop at max. pressure.	Filter clogged. Head gasket or valve fault.	Replace filter element. Contact Authorised Service Agent.
Compressor noisy with metallic knock.	Bearing or piston damage.	Contact Authorised Service Agent.

Declaration of Conformity We, the sole importer into the UK, declare that the product listed here is in conformity with the following standards and directives.

DIRECT DRIVE COMPRESSOR
Model: SA2250/2.V2
 2006/42/EC Machinery Directive
 87/404/EEC Pressure Vessel Directive
 2006/95/EC Low Voltage Directive
 2004/108/EC EMC Directive
 93/68/EEC CE Marking Directive







The construction file for this product is held by the Manufacturer and may be inspected, by a national authority, upon request to Jack Sealey Ltd.

Signed by Mark Sweetman  28th February 2008

*For Jack Sealey Ltd.
Sole importer into the UK
of Sealey Power Products*

NOTE: It is our policy to continually improve products and as such we reserve the right to alter data, specifications and component parts without prior notice. **IMPORTANT:** No liability is accepted for incorrect use of this equipment. **WARRANTY:** Guarantee is 12 months from purchase date, proof of which will be required for any claim. **INFORMATION:** For a copy of our latest catalogue and promotions call us on 01284 757525 and leave your full name and address, including postcode.

	Sole UK Distributor Sealey Group, Bury St. Edmunds, Suffolk.	 01284 757500  01284 703534	 www.sealey.co.uk  sales@sealey.co.uk
---	--	--	--

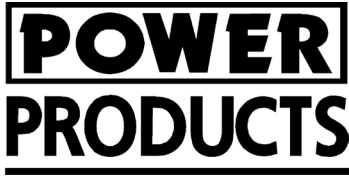

PARTS LIST FOR:
**DIRECT DRIVE
 COMPRESSOR**
 MODEL NO: **SA2250/2.V2**

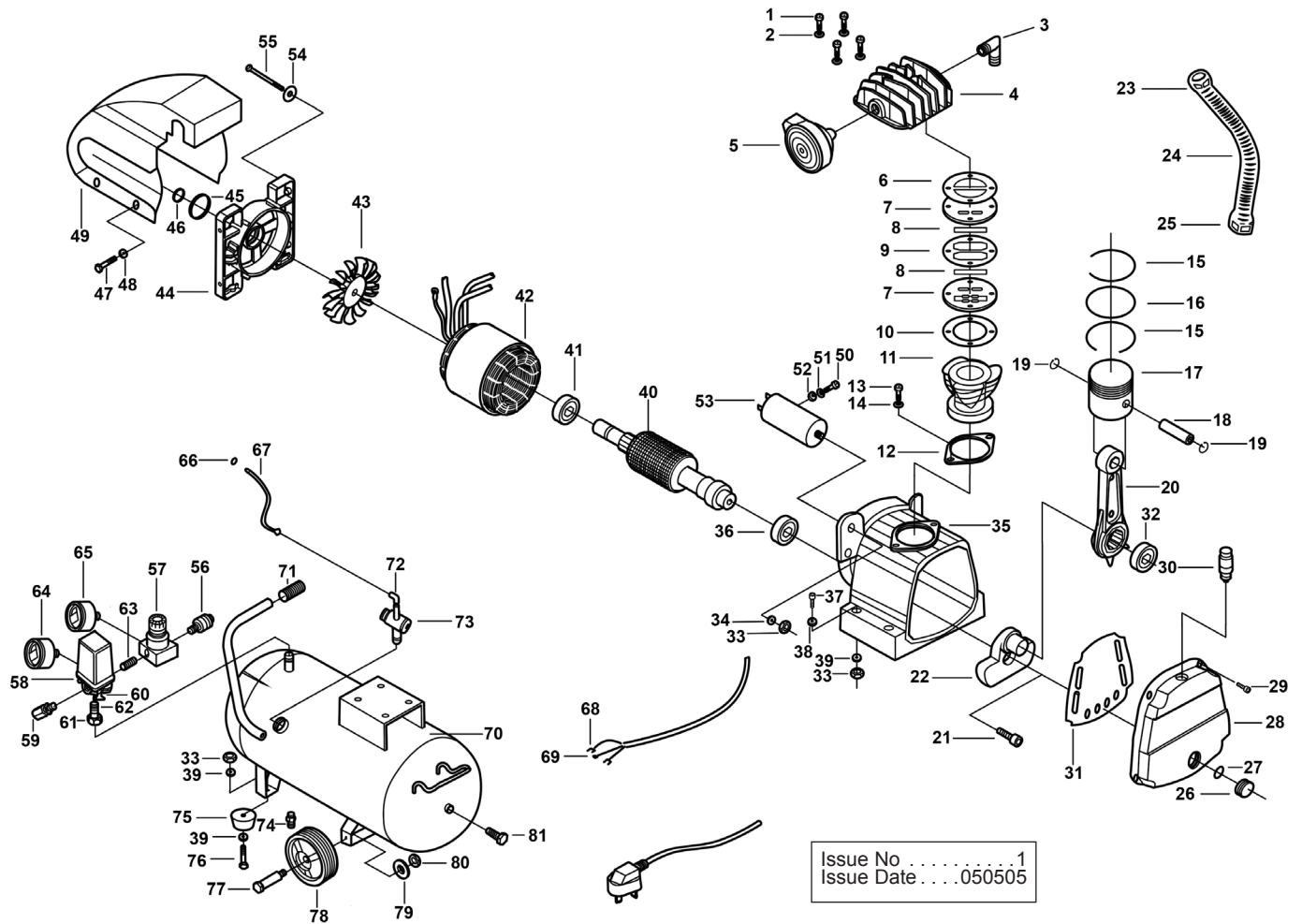

ITEM	PART NO.	DESCRIPTION	ITEM	PART NO.	DESCRIPTION	ITEM	PART NO.	DESCRIPTION
01.	SA2250-V2.01	BOLT	28.	SA2250-V2.28	FRONT CAP	55.	SA2250-V2.55	BOLT
02.	SA2250-V2.02	SPRING WASHER	29.	SA2250-V2.29	BOLT	56.	SA2250-V2.56	AIR COCK
03.	SA2250-V2.03	EXHAUST ELBOW	30.	SA2250-V2.30	BREATHER	57.	SA2250-V2.57	REGULATOR
04.	SA2250-V2.04	CYLINDER HEAD	31.	SA2250-V2.31	GASKET	58.	SA2250-V2.58	PRESSURE SWITCH
05.	SA2250-V2.05	AIR FILTER	32.	SA2250-V2.32	SHAFT SEAL	59.	SA2250-V2.59	SAFETY VALVE
06.	SA2250-V2.06	GASKET	33.	SA2250-V2.33	NUT	60.	SA2250-V2.60	NUT
07.	SA2250-V2.07	VALVE ASS'Y	34.	SA2250-V2.34	WASHER	61.	SA2250-V2.61	CONNECTOR
08.	SA2250-V2.08	VALVE	35.	SA2250-V2.35	CRANKCASE	62.	SA2250-V2.62	GASKET
09.	SA2250-V2.09	GASKET	36.	B/6204-2RS	BEARING	63.	SA2250-V2.63	CONNECTOR
10.	SA2250-V2.10	CYLINDER GASKET	37.	SA2250-V2.37	BOLT	64.	SA2250-V2.64	PRESSURE GAUGE
11.	SA2250-V2.11	CYLINDER	38.	SA2250-V2.38	SPRING WASHER	65.	SA2250-V2.65	PRESSURE GAUGE
12.	SA2250-V2.12	CYLINDER GASKET	39.	SA2250-V2.39	WASHER	66.	SA2250-V2.66	UNLOADING SCREW NUT
13.	SA2250-V2.13	BOLT	40.	SA2250-V2.40	ROTOR	67.	SA2250-V2.67	UNLOADING PIPE
14.	SA2250-V2.14	SPRING WASHER	41.	B/6202-2RS	BEARING	68.	SA2250-V2.69	CABLE CONNECTOR
15.	SA2250-V2.15	GAS RING	42.	SA2250-V2.42	STATOR	69.	SA2250-V2.70	CABLE CONNECTOR
16.	SA2250-V2.16	OIL RING	43.	SA2250-V2.43	FAN	70.	SA2250-V2.72	TANK
17.	SA2250-V2.17	PISTON	44.	SA2250-V2.44	REAR CAP	71.	SA2250-V2.73	HANDLE GRIP
18.	SA2250-V2.18	WRIST PIN	45.	SA2250-V2.45	WASHER	72.	SA2250-V2.74	SMALL ELBOW
19.	SA2250-V2.19	ELASTIC COLLAR	46.	SA2250-V2.46	WASHER	73.	SA2250-V2.75	CHECK VALVE
20.	SA2250-V2.20	CONNECTING ROD	47.	SA2250-V2.47	BOLT	74.	SA2250-V2.76	DRAIN VALVE
21.	SA2250-V2.21	BOLT	48.	SA2250-V2.48	WASHER	75.	SA2250-V2.77	RUBBER FOOT
22.	SA2250-V2.22	CRANK SHAFT	49.	SA2250-V2.49	PUMP HEAD HOUSING	76.	SA2250-V2.78	BOLT
23.	SA2250-V2.23	NUT	50.	SA2250-V2.50	BOLT	77.	SA2250-V2.79	ROLLER SHAFT BOLT
24.	SA2250-V2.24	EXHAUST PIPE	51.	SA2250-V2.51	SPRING WASHER	78.	SA2250-V2.80	WHEEL
25.	SA2250-V2.25	COOLING EXHAUST NUT	52.	SA2250-V2.52	WASHER	79.	SA2250-V2.81	SPRING WASHER
26.	SA2250-V2.26	OIL SIGHT GLASS	53.	SA2250-V2.53	CAPACITOR	80.	SA2250-V2.82	NUT
27.	SA2250-V2.27	OIL SIGHT GLASS RING	54.	SA2250-V2.54	SPRING WASHER	81.	SA2250-V2.83	CASING CAP



Sole UK Distributor, Sealey Group, Bury St. Edmunds, Suffolk.

01284 757500

01284 703534



www.sealey.co.uk



sales@sealey.co.uk