

PARTS LIST FOR:
**AIR OPERATED
 ORBITAL SANDER**
 MODEL NO: **SA10.V2**

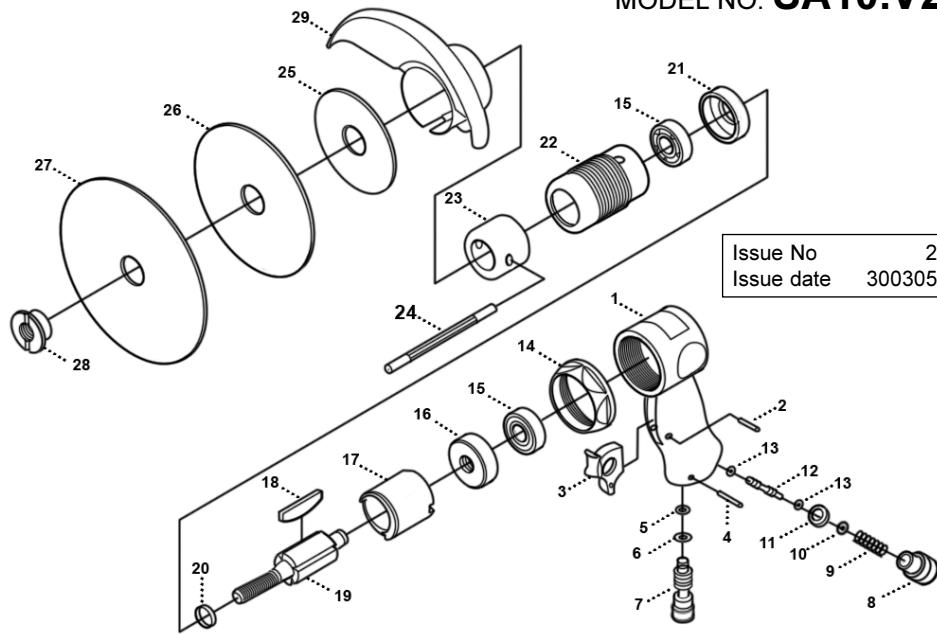

ITEM	PART NO.	DESCRIPTION
01.	SA10/96-03	HANDLE
02.	SA10/96-16	PIN
03.	SA10/96-07	TRIGGER
04.	SA10/96-26	PIN
05.	SA10/96-30	O-RING
06.	SA10/96-31	O-RING
07.	SA10/96-32	AIR REGULATOR
08.	SA10/96-29	INLET BUSHING
09.	SA10/96-24	SPRING
10.	SA10/96-23	STEEL BALL 9.3MM
11.	SA10/96-22	BALL SEAT
12.	SA10/96-28	PUSH ROD
13.	SA10/28P	O-RING
14.	SA10/96-40	HOUSING LOCK RING
15.	B/6201ZZ	BEARING

ITEM	PART NO.	DESCRIPTION
16.	SA10/96-42	REAR END PLATE
17.	SA10/96-43	CYLINDER
18.	SA10/96-44	ROTOR VANE
19.	SA10/96-45-2	ROTOR 98MM
20.	SA10/96-46	BUSHING
21.	SA10/96-47	FRONT END PLATE
22.	SA10/96-48	CYLINDER HOUSING
23.	SA10/96-49-2	ADAPTOR 30MM
24.	SA10/96-50	HOLDING TOOL
25.	SA10/96-51	BACKING DISC 3"
26.	SA10/96-52	BACKING DISC 4-1/2"
27.	SA10/96-53	BACKING DISC 5-1/2"
28.	SA10/96-54	ADAPTOR LOCK
29.	SA10/DG	DISC GUARD

NOTE: It is our policy to continually improve products and as such we reserve the right to alter data, specifications and component parts without prior notice. **IMPORTANT:** No liability is accepted for incorrect use of this equipment. **WARRANTY:** Guarantee is 12 months from purchase date, proof of which will be required for any claim. **INFORMATION:** For a copy of our latest catalogue and promotions call us on 01284 757525 and leave your full name and address, including postcode.



INSTRUCTIONS FOR:
**AIR OPERATED
 ORBITAL SANDER**
 MODEL NO: **SA10.V2**

Thank you for purchasing a Sealey Product. Manufactured to a high standard this product will, if used according to these instructions and properly maintained, give you years of trouble free performance.

IMPORTANT: PLEASE READ THESE INSTRUCTIONS CAREFULLY. NOTE THE SAFE OPERATIONAL REQUIREMENTS, WARNINGS AND CAUTIONS. USE THIS PRODUCT CORRECTLY AND WITH CARE FOR THE PURPOSE FOR WHICH IT IS INTENDED. FAILURE TO DO SO MAY CAUSE DAMAGE AND/OR PERSONAL INJURY AND WILL INVALIDATE THE WARRANTY. PLEASE KEEP INSTRUCTIONS SAFE FOR FUTURE USE.

1. SAFETY INSTRUCTIONS

- WARNING!** Ensure Health & Safety, local authority, and general workshop practice regulations are adhered to when using this equipment.
- WARNING!** Disconnect from air supply before changing accessories or servicing.
- ✓ Maintain the sander in good condition (use an authorised service agent).
- ✓ Replace or repair damaged parts. Use genuine parts only. Unauthorised parts may be dangerous and will invalidate the warranty.
- ✓ Use in suitable clean and tidy working area, free from unrelated materials and ensure there is adequate lighting.
- ✓ Before each use check abrasive pads for condition. If worn or damaged replace immediately.
- ✓ Ensure the abrasive pad rating is the same as, or greater than, the RPM rating of the sander.
- ✓ Ensure there are no flammable or combustible materials near the work area.
- WARNING!** Always wear approved eye, face and hand protection when operating the sander.
- ✓ Use dust / respiratory protection in accordance with COSHH regulations.
- ✓ Depending on the task, sander noise level may exceed 85dB in which case wear safety ear defenders.
- ✓ Remove ill fitting clothing. Remove ties, watches, rings, other loose jewellery, and contain and/or tie back long hair.
- ✓ Wear appropriate protective clothing and keep hands and body clear of working parts.
- ✓ Maintain correct balance and footing. Ensure the floor is not slippery and wear non-slip shoes.
- ✓ Keep children and unauthorised persons away from the working area.
- ✓ Check moving parts alignment on a regular basis.
- ✓ Ensure workpiece is secure before operating the sander. Never hold a workpiece by hand.
- ✓ Check the workpiece to ensure there are no protruding screws, bolts, nuts, nails, stones, etc.
- ✓ Avoid unintentional starting.
- WARNING!** Ensure correct air pressure is maintained and not exceeded. Recommended pressure 70-90psi
- ✓ Keep air hose away from heat, oil and sharp edges. Check air hose for wear before each use and ensure that all connections are secure.
- ✓ Prolonged exposure to vibration from this sander poses a health risk. It is the owner's responsibility to correctly assess the potential hazard and issue guidelines for safe periods of use and offer suitable protective equipment.
- x DO NOT use the sander for a task it is not designed to perform.
- x DO NOT operate sander if any parts are damaged or missing as this may cause failure and/or personal injury.
- x DO NOT use cloth backed sanding pads. Use only appropriate paper adhesive pads, following pad instructions.
- WARNING!** DO NOT sand any materials containing asbestos.
- x DO NOT carry the sander by the hose, or yank the hose from the air supply.
- x DO NOT place attachments close to your face and do not point at other persons or animals.
- x DO NOT operate sander when you are tired or under the influence of alcohol, drugs or intoxicating medication.
- x DO NOT use sander where there are flammable liquids, solids or gases such as paint solvents and including waste wiping or cleaning rags etc.
- x **DO NOT attempt to attach a grinding disc to this sander since the machine speed of 18,000 rpm would cause a disc to shatter.**
- x DO NOT carry the sander with your finger on the power lever.
- x DO NOT direct air from the air hose at yourself or others.
- ✓ When not in use disconnect from air supply and store in a safe, dry, childproof location.

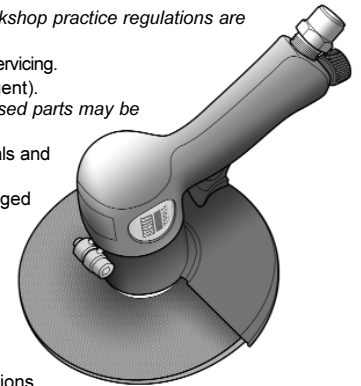

1.2. LEAD PAINT WARNING!

Paint once contained lead as a traditional ingredient. Contact with the dust from the removal of such paint is toxic and must therefore be avoided. The following action must be taken before using the sander on a surface that you suspect may contain lead paint.

1. User must determine potential hazard relating to age of paint to be removed. (Modern paints do not have lead content).
2. **DANGER!** Keep all persons and pets away from the working area. The following persons are particularly vulnerable to the effects of lead paint dust: *Expectant women, babies and children.*
3. We recommend personal protection by using the following safety items:
 - a) Paint Spray Respirator (Our ref SSP16EN)
 - b) PE Coated Hooded Coverall (Our ref SSP266).
 - c) Latex Gloves (Our ref SSP24).
4. Take adequate measures to contain the paint dust, flakes and scrapings.
5. Continue to wear safety equipment as in (3) above and thoroughly clean all areas when task is complete. Ensure paint waste is disposed of in sealed bags or containers.

Risk of Hand Arm Vibration Injury

Air Operated Orbital Sander Model No. SA10.V2 when operated in accordance with these instructions and tested in accordance with EN 28662-1: 1993 results in the following vibration emission declared in accordance with BS EN12096: 1996.

Measured vibration emission value:5.0m/s²

Uncertainty:2.0m/s²

These values are suitable for comparison with emission levels of other tools that have been subject to the same test.

This tool may cause hand-arm vibration syndrome if its use is inadequately managed.

Recommended Measures to reduce risk of hand-arm vibration syndrome:

This tool should not be used by an individual regularly for more than 4 hours in any 8 hour period.

This duration of use should be reduced if the individual is exposed to hand-arm vibration from other sources.

2. INTRODUCTION & SPECIFICATION

The SA10 is a direct-drive, pistol type sander with aluminium body and steel safety guard. Fitted with air-flow speed control and supplied with 3 sizes of backing pads suitable for flexible sanding discs.

Pad sizes76,114,140mm	Air Inlet1/4" BSP
Free Speedup to 18000rpm	Sound95.2dB (A)
Operating Pressure90psi	Vibration5m/s ²
Air Consumption4cfm		

3. PREPARING SANDER FOR USE

3.1 AIR SUPPLY

Recommended hook-up procedure is shown in fig 1.

- 3.1.1 Ensure the sander air valve (or throttle) is in the "off" position before connecting to the air supply.
- 3.1.2 You will require an air pressure between 70-90psi, and an air flow according to the specification above.

WARNING! Ensure the air supply is clean and does not exceed 90 psi while operating the sander. (Too high an air pressure and unclean air will shorten the product life due to excessive wear, and may be dangerous causing damage and/or personal injury.)

- 3.1.3 Drain the air tank daily. Water in the air line will damage the sander **and will invalidate your warranty.**
- 3.1.4 Clean air inlet filter weekly.
- 3.1.5 Line pressure should be increased to compensate for unusually long air hoses (over 8 metres). The minimum hose diameter should be 1/4" I.D. and fittings must have the same inside dimensions.
- 3.1.6 Keep hose away from heat, oil and sharp edges. Check hoses for wear, and make certain that all connections are secure.

3.2 COUPLINGS

Vibration may cause failure if a quick change coupling is connected directly to the air sander. To overcome this, connect a leader hose to the sander. A quick change coupling may then be used to connect the leader hose to the air line recoil hose. See fig 1 & 2 on next page.

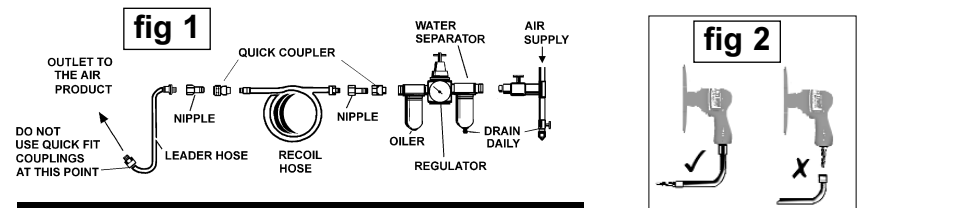

4. OPERATING INSTRUCTIONS

WARNING! Ensure you read, understand and apply safety instructions before use.

4.1 ASSEMBLY

- 4.1.1 Place the guard (fig.3 - 3) around the gun collar (4). Position the guard with the clamp at the top and tighten the clamp screw.
- 4.1.2 Remove lock nut (1) from gun hub and push lock nut through the centre of the appropriate size backing disc (2). The lock nut must be an exact fit in the backing disc. Screw the lock nut with the disc attached back into the gun hub. Hold the hub steady by inserting the holding rod provided into one of the holes in the side of the hub.(5)
- 4.1.3 Connect air supply to the air inlet (8) on the sander and press the control valve trigger (6) to check that the sander is working correctly.
- 4.1.4 The air flow may be regulated by turning the control knob (7) at the base of the gun handle.

4.2 OPERATION

Always use the grit pad appropriate for the job. Work progressively from coarse grades to finer grades. **DO NOT** go from coarse to fine in one step as it may be difficult to remove swirl marks left by the coarser grit. **DO NOT** apply excessive pressure, let the sander do the work for you. Start the sander and bring the sanding disc to the work surface evenly and slowly. Move the sander back and forth in overlapping areas. Remove the sanding disc from the work surface before stopping the sander. Regularly check the sanding pad for wear, always changed a cracked or damaged pad. **DO NOT** allow sander to run in "idle rotation" for an extended period as this will increase bearing wear.

5. MAINTENANCE

- WARNING!** Disconnect sander from air supply before changing accessories, servicing or performing maintenance. Replace or repair damaged parts. *Use genuine parts only. Unauthorised parts may be dangerous and will invalidate the warranty.*
- 5.1 Lubricate the air saw daily either with a few drops of Sealey air tool oil dripped into the air inlet or via an oiler in the air supply.
 - 5.2 Clean the sander after use and change pads when required.
 - 5.3 Loss of power or erratic action may be due to the following:
 - a) Excessive drain on the air line. Moisture or restriction in the air pipe. Incorrect size or type of hose connectors. To remedy check the air supply and follow instructions in chapter 3.
 - b) Grit or gum deposits in the sander may also reduce performance. If your model has an air strainer (located in the area of the air inlet), remove the strainer and clean it. Flush the sander out with gum solvent oil or an equal mixture of SAE No 10 oil and kerosene. Allow to dry before use. If you continue to experience problems, contact your local Sealey service agent.
 - 5.4 For a full service contact your local Sealey service agent.
 - 5.5 When not in use, disconnect from air supply, clean sander and store in a safe, dry, childproof location.

Declaration of Conformity

CE We, the sole importer into the UK, declare that the product listed here is in conformity with the following standards and directives. The construction file for this product is held by the Manufacturer and may be inspected, by a national authority, upon request to Jack Sealey Ltd.

AIR OPERATED ORBITAL SANDER
Model: SA10.V2

98/37/EC Machinery Directive
93/68/EEC Marking Directive

Signed by Mark Sweetman

4th March 2005

For Jack Sealey Ltd. Sole importer into the UK of Sealey Power Products.