

Thank you for purchasing a Siegen product. Manufactured to a high standard this product will, if used according to these instructions and properly maintained, give you years of trouble free performance.



IMPORTANT: PLEASE READ THESE INSTRUCTIONS CAREFULLY. NOTE THE SAFE OPERATIONAL REQUIREMENTS, WARNINGS & CAUTIONS. USE THE PRODUCT CORRECTLY AND WITH CARE FOR THE PURPOSE FOR WHICH IT IS INTENDED. FAILURE TO DO SO MAY CAUSE DAMAGE AND/OR PERSONAL INJURY, AND WILL INVALIDATE THE WARRANTY. PLEASE KEEP INSTRUCTIONS SAFE FOR FUTURE USE.

1. SAFETY INSTRUCTIONS

1.1. ELECTRICAL SAFETY

WARNING! It is the responsibility of the owner and the operator to read, understand and comply with the following: You must check all electrical products, before use, to ensure that they are safe. You must inspect power cables, plugs, sockets and any other connectors for wear or damage. You must ensure that the risk of electric shock is minimised by the installation of appropriate safety devices. A Residual Current Circuit Breaker (RCCB) should be incorporated in the main distribution board. We also recommend that a Residual Current Device (RCD) is used. It is particularly important to use an RCD with portable products that are plugged into a supply which is not protected by an RCCB. If in any doubt consult a qualified electrician. You may obtain a Residual Current Device by contacting your Siegen dealer.

You must also read and understand the following instructions concerning electrical safety.

- 1.1.1. The **Electricity at Work Act 1989** requires all portable electrical appliances, if used on business premises, to be tested by a qualified electrician, using a Portable Appliance Tester (PAT), at least once a year.
- 1.1.2. The **Health & Safety at Work Act 1974** makes owners of electrical appliances responsible for the safe condition of those appliances and the safety of the appliance operators. **If in any doubt about electrical safety, contact a qualified electrician.**
- 1.1.3. Ensure that the insulation on all cables and on the appliance is safe before connecting it to the power supply. See 1.1.1. and 1.1.2. and use a Portable Appliance Tester.
- 1.1.4. Ensure that cables are always protected against short circuit and overload.
- 1.1.5. Regularly inspect power supply cables and plugs for wear or damage and check all connections to ensure that none is loose.
- 1.1.6. **Important:** Ensure that the voltage marked on the appliance matches the power supply to be used and that the plug is fitted with the correct fuse - see fuse rating at right.
- 1.1.7. **DO NOT** pull or carry the appliance by the power cable.
- 1.1.8. **DO NOT** pull the plug from the socket by the cable.
- 1.1.9. **DO NOT** use worn or damaged cables, plugs or connectors. Immediately have any faulty item repaired or replaced by a qualified electrician. When an ASTA/BS approved UK 3 pin plug is damaged, cut the cable just above the plug and **dispose of the plug safely.** Fit a new plug according to the following instructions (UK only).
 - a) **Connect the GREEN/YELLOW earth wire to the earth terminal 'E'.**
 - b) **Connect the BROWN live wire to the live terminal 'L'.**
 - c) **Connect the BLUE neutral wire to the neutral terminal 'N'.**
 - d) **After wiring, check that there are no bare wires, that all wires have been correctly connected, that the cable outer insulation extends beyond the cable restraint and that the restraint is tight.**

Double insulated products, which are always marked with this symbol , are fitted with live (brown) and neutral (blue) wires only. To rewire, connect the wires as indicated above - **DO NOT** connect either wire to the earth terminal.
- 1.1.10. Products which require more than 13 amps are supplied without a plug. In this case you must contact a qualified electrician to ensure that a suitably rated supply is available. We recommend that you discuss the installation of an industrial round pin plug and socket with your electrician.
- 1.1.11. If an extension reel is used it should be fully unwound before connection. A reel with an RCD fitted is preferred since any appliance plugged into it will be protected. The cable core section is important and should be at least 1.5mm², but to be absolutely sure that the capacity of the reel is suitable for this product and for others which may be used in the other output sockets, we recommend the use of 2.5mm² section cable. If extension reel is to be used outdoors, ensure it is marked for outdoor use.

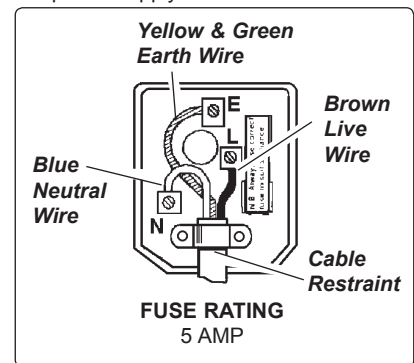

1.2 GENERAL SAFETY

- ✓ Disconnect the drill from the mains power before changing accessories, servicing or performing any maintenance.
- ✓ Maintain drill in good condition. Check moving parts and alignment, and keep drill bits sharp. If necessary use an authorised service agent.
- ✓ Replace or repair damaged parts. *Use recommended parts only. Unauthorised parts may be dangerous and will invalidate the warranty.*
- ✓ Wear approved safety eye protection with side shields, and a dust mask if drilling generates dust. Rubber gloves are recommended when using outdoors, and safety gloves when drilling items such as steel, brickwork etc,
- ✓ Remove ill fitting clothing. Remove ties, watches, rings, and other loose jewellery, and contain long hair.
- ✓ Use drill in an adequate working area for its function, keep area clean, tidy and free from unrelated materials, and ensure adequate lighting.
- ✓ Prevent body contact with grounded surfaces to avoid electric shock i.e. pipes, radiators, ranges, refrigerators etc.
- ✓ Evaluate your working area before using the drill i.e. ceiling, floors and enclosures may contain hidden electrical wires or water piping.
- ✓ Maintain correct balance and footing. **DO NOT** over-reach and ensure the floor is not slippery and wear non-slip shoes.
- ✓ The supplementary handle grip should always be attached for use.
- ✓ Keep children and unauthorised persons away from the working area.
- ✓ Secure unsecured workpiece with a clamp, vice or other adequate holding device. **DO NOT** hold unsecured work in your hand.
- ✓ Avoid unintentional starting, and ensure the lock-on button is disengaged before use.
- ✗ **DO NOT** use the drill for a task it is not designed to perform.
- ✗ **DO NOT** operate drill where there are flammable liquids or gasses.
- ✗ **DO NOT** get the drill wet or use in damp or wet locations.
- ✗ **DO NOT** operate the drill if any parts are missing or the drill is damaged, as this may cause failure and/or possible personal injury.
- ✗ **DO NOT** operate the drill when you are tired or under the influence of alcohol, drugs or intoxicating medication.
- ✗ **DO NOT** carry the drill with your finger on the power switch, or carry by the power cord, or leave the drill running whilst unattended.
- ✓ When not in use, switch drill off, remove plug from power supply, clean the drill and store in safe, dry, childproof location.

2. TECHNICAL SPECIFICATION

Input power: 230V - 50Hz
 Motor: 800W
 No load speed: 2900rpm
 Chuck capacity: 13mm
 Hammer action: 46400bpm
 Drilling capacity for steel: 13mm

Drilling capacity for masonry: 13mm
 Drilling capacity for wood: 32mm
 Weight: 2.4kg
 Sound pressure level: 94.0dB(A)
 Sound power level: 105.0dB(A)
 Vibration level: 10.7m/s²

1. Trigger lock button
2. Trigger
3. Variable speed knob
4. Forward/Reverse switch
5. Drill/Impact switch
6. Chuck

7. Depth gauge
8. Side handle
9. Chuck key

Fig.1

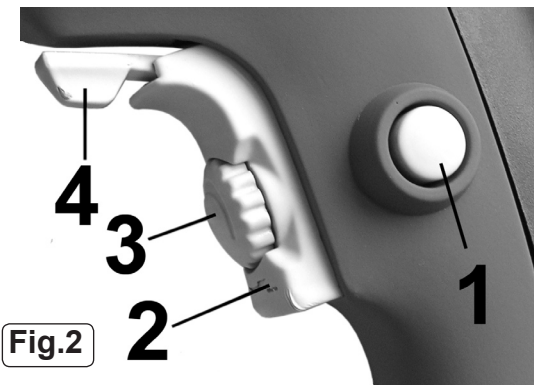
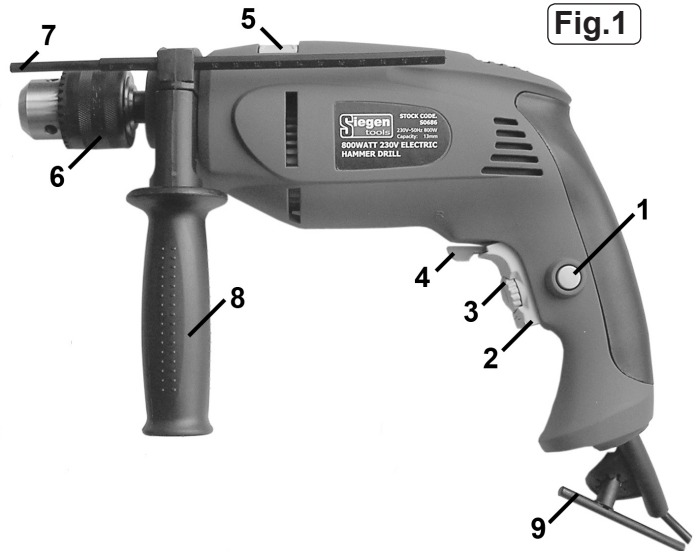

Fig.2

3. OPERATING INSTRUCTIONS

3.1. PREPARING DRILL FOR USE.

- 3.1.1. Ensure the drill is switched off and unplugged from the mains power supply.
- 3.1.2. **Fitting the side handle.** (Fig.1.8) Fit side handle grip by placing the handle assembly over the chuck and onto the machine neck. Secure by rotating the handle clockwise until it is tight and the handle can no longer be moved. To ensure a good grip in all circumstances, the angle of the handle may be changed by rotating the handle grip anticlockwise until the handle assembly is loose. Rotate the handle to the desired angle and retighten.
- 3.1.3. **Fitting the depth gauge.** (Fig.1.7) To fit the depth gauge loosen the side handle and pass the gauge through the handle clamp to the required depth. Rotate the handle to the required angle. As the handle is tightened the depth gauge will also be gripped firmly.

3.2. DRILL CONTROLS

- 3.2.1. **ON/OFF Variable speed trigger.** The drill has a variable speed control On/Off trigger (Fig.1.2) speed increases as the trigger is depressed. Adjacent to the trigger is a button that can be used to lock the trigger in the 'ON' position for continuous drilling.
- 3.2.2. **Trigger lock.** (Fig.1.1) To lock 'ON', depress the trigger, push in and hold the button then release the trigger. Release the lock-on button and the drill will continue running.
- 3.2.3. To release the lock, depress the trigger and the lock releases.
- 3.2.4. Power failure. If you have the lock-on feature engaged during use and the drill becomes disconnected from the power supply, make sure that the lock is released, before reconnecting to the power supply.
 WARNING! Before connecting the drill to a power supply, ensure it is not in the lock-on position as this may result in damage and personal injury. Depress the trigger to ensure release. DO NOT use the lock-on facility for jobs where the drill may need to be stopped suddenly.
- 3.2.5. **Maximum speed setting control.** The variable speed trigger has a small rotating knob incorporated into it (Figs.1.3 & 2.3) which can be used to control the maximum speed of the drill. When the knob is set to the maximum or + setting the trigger can be fully depressed allowing the drill to turn at its maximum speed. As the knob is turned towards the minimum or - setting, the movement of the trigger is restricted so that the drill will turn at a lower pre-set speed when the trigger is fully depressed. This facility is useful when working with materials that should be drilled at a constant, lower speed.
- 3.2.6. The required speed will depend on the material and task in hand. The following may be used as a general guide.
 - a) Low speeds are recommended for hard materials, i.e. stone, ceramic, concrete, high tensile steel, and tasks such as starting holes without centre punch, driving screws, mixing paint etc.
 - b) Medium speeds are suitable for plastics and laminates.
 - c) High speeds recommended for soft materials such as wood, aluminium, copper, bronze and brass.

▲ **CAUTION: DO NOT run the drill at low to medium speeds for extended periods of time as this may cause drill to overheat. To cool drill, run it without a load, at full speed, for a few seconds.**

- 3.2.7. **Direction of rotation.** Select either forward or reverse rotation using the lever mounted directly above the trigger (Figs.1.4 & 2.4). Select reverse by moving the lever towards the 'L' symbol and forward by moving the lever adjacent to the 'R' symbol and the trigger lock button.

▲ **CAUTION: Do not attempt to change direction of rotation whilst the drill is still running.**

- 3.2.8. **Selection of hammer action / drilling.** When using a masonry drill bit, the hammer action can be used to assist penetration into concrete, stone and masonry. The hammer action selector is a large sliding 'switch' situated on top of the drill (Fig.3). To select hammer action slide the selector to the left so that it is adjacent to the hammer symbol moulded on the side of the case. To disable the hammer action slide the switch in the other direction to be adjacent to the drill symbol moulded on the casing.

3.3. DRILL OR TOOL BIT FITTING.

WARNING! Unplug from the mains power supply before placing bit into chuck.

Adjust the chuck jaws to a point where the opening is slightly larger than the drill / tool bit (Fig.4.A) to be used. Also raise the front of the drill slightly to stop the bit from falling out of the chuck jaws. Insert the drill / tool bit into the chuck as far as it will go. Place the chuck key in one of the chuck holes and tighten the chuck fully by turning the chuck key clockwise (Fig.4.9).

