

Model No's: **RW2500/12.V2, RW3500/12.V2, RW4500/12.V2,
RW2500/24.V2, RW3500/24.V2, RW4500/24.V2.**

Thank you for purchasing a Sealey product. Manufactured to a high standard this product will, if used according to these instructions and properly maintained, give you years of trouble free performance.



IMPORTANT: PLEASE READ THESE INSTRUCTIONS CAREFULLY. NOTE THE SAFE OPERATIONAL REQUIREMENTS, WARNINGS & CAUTIONS. USE THE PRODUCT CORRECTLY AND WITH CARE FOR THE PURPOSE FOR WHICH IT IS INTENDED. FAILURE TO DO SO MAY CAUSE DAMAGE AND/OR PERSONAL INJURY AND WILL INVALIDATE THE WARRANTY. PLEASE KEEP INSTRUCTIONS SAFE FOR FUTURE USE.

1. SAFETY INSTRUCTIONS

- IMPORTANT WARNING!** DO NOT pull the the cable at an angle of more than 10° (fig A). Pulling angles greater than 10° will put excessive pressure on cable drum and will result in damage to winch and invalidate the warranty.
- WARNING!** Your winch is NOT designed for lifting or slinging loads. It is intended only for pulling a load and must be used with care.
- ✓ The winch is designed to take the strain of a load as a temporary manoeuvre and should not be used to hold or secure a load when winching has been completed. Maximum operating time should not exceed two minutes. If the load fails to move, or stops, switch off winch within thirty seconds to prevent winch damage.
- ✓ Fit only appropriately rated cable and hook-up suitable for the task for which the winch is to be used.
- ✓ Ensure the winch is maintained in a safe working condition. Inspect the cable regularly checking for fraying, kinks, broken strands or distortion. If such appears, replace the cable. Check all component parts, do not use if damaged, contact authorised service agent. USE ONLY GENUINE PARTS SUPPLIED BY SEALEY.
- ✓ Choose an appropriately strong winching point, which we recommend is reinforced with steel plates and appropriate securing bolts. The winch mounting point must be capable of withstanding loads greater than the maximum rated capacity of the winch.
- ✓ Ensure you plug the remote control switch cable into the winch before connecting the power supply cable.
- ✓ Ensure the winch is correctly connected to a 12V or 24V power supply, according to the model in use.
- ✓ Ensure connection to battery is undertaken in accordance with the safe connecting and handling instructions for the battery.
- ✓ Ensure power cables are safely placed away from winch cable and will not be accidentally caught up in the winching process.
- ✓ The vehicle from which the battery will be used must be in neutral gear with the hand brake fully on and the wheels chocked.
- ✓ Keep the vehicle engine running whilst the winch is being used so that the battery is not drained.
- ✓ Check running direction of the winch drum before use.
- WARNING!** Keep hands, body and clothing away from the winch components and the cable. Use a rag or protective gloves when handling cable. Take any necessary precautions to protect your personal safety whilst using the winch.
- ✓ For a heavy load, place a blanket (or similar) over extended cable about two feet away from hook to lessen the severity of a cable break.
- WARNING!** Ensure you know how much load you are winching. Never exceed the maximum pulling capacity. Take into account any angle of incline over which the load must be pulled and the additional loading when winching from thick mud, or through snow or water. Chock the wheels of vehicle to be winched, then release any brakes and place gears in neutral. Ensure the load is capable of free movement before winching. Take the strain on cable and remove wheel chocks to move the load.
- ✓ Ensure the load to be pulled has an appropriate fixing point. If not, fit an adequate sling, eyebolt or other accessory to the load. Ensure accessories are equal to, or exceed, winch maximum pulling capacity.
- ✓ Ensure cable is securely attached to the load before winching.
- ✓ Maintain correct balance and footing whilst using the winch.
- ✓ Remove ill fitting clothing. Remove ties, watches, rings and other loose jewellery and contain and/or tie back long hair.
- ✓ Keep children and non-essential persons away from the operating area. Be aware of the location of other persons assisting you.
- ✓ Should the winch vibrate or emit a noise during use, stop immediately and check to identify and solve the problem.
- ✗ DO NOT operate the winch if any parts are damaged or missing as this may cause failure and/or personal injury.
- ✗ DO NOT disconnect the electrical power supply during winching.
- WARNING!** DO NOT use winch as a lifting device of any type (fig B). DO NOT use the winch for any purpose other than that for which it is designed.
- WARNING!** DO NOT exceed the rated pulling capacity of the winch.
- ✗ DO NOT pull cable over or around a corner and DO NOT take hook around load and back onto cable. Use appropriate sling or pulley if necessary.
- ✗ DO NOT operate the winch with less than FIVE wraps of cable on the drum. The end of the cable is red, do not use with any of the red cable off the drum.
- ✗ DO NOT operate winch if you are tired, under the influence of alcohol, drugs or intoxicating medication.
- ✓ When not in use, place the clutch in engaged position. Disconnect winch from power supply and store remote control and power cable in a safe, dry location.

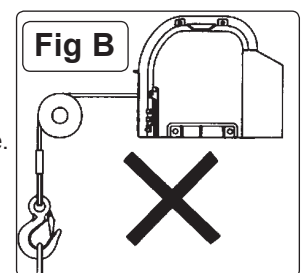
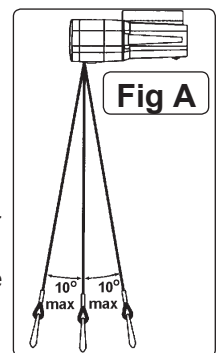

2. SPECIFICATIONS & PERFORMANCE

Suitable for direct vehicle mounting as well as truck and trailer bed mounting, these high speed winches offer a combination of performance with durability. The compact design allows mounting in areas where space is at a premium.

- Heavy-duty all-weather housing.
- High power DC motors give first class pulling power.
- All steel, lubricated for life, gear-train for smooth and quiet operation.
- Includes dynamic and mechanical drum brake for safe and controlled operation.
- Remote control allows power in and power out of cable from a safe distance.
- Drum clutch allows free spooling of cable.
- High quality wire rope fed through 4-way roller fairlead for smooth and even distribution of cable onto drum.
- Supplied with automatic resetting circuit breaker and hand-saver bar.

CHART 1.

MODEL	RW2500/12.V2 RW2500/24.V2		RW3500/12.V2 RW3500/24.V2		RW4500/12.V2 RW4500/24.V2	
	lb	kg	lb	kg	lb	kg
Layer						
1	2,500	1,134	3,500	1,588	4,500	2,041
2	2,061	935	2,888	1,310	3,714	1,685
3	1,753	795	2,457	1,114	3,159	1,433
4	1,527	693	2,141	971	2,750	1,247
5			1,894	859	2,435	1,104

LINE PULL AND LINE SPEED vary according to how much cable is on the drum. The winch is rated at the first layer of cable on the drum. The maximum line pull force will be reduced by subsequent layers of cable on the drum. Chart 1 illustrates the maximum line force at increasing cable layers. You could experience a loss of 13% pulling power per layer of cable. Also check any incline on which you are pulling as an incline will further reduce the line pulling capacity, see Chart 6.

COMPONENTS

Check that you have the equipment as shown below. If any item is missing or damaged contact your supplier immediately.

CHART 2.

Model	RW2500.V2	RW3500.V2	RW4500.V2	
Rated Line Pull	lb	2,500	3,500	4,500
	kg	1,134	1,588	2,041
Voltage(DC)	V	12VDC or 24VDC		
Motor	hp	0.8	1.2	1.6
	w	600	900	1,200
Gear Train	3 stages planetary gears			
Gear Ratio	170:1	170:1	170:1	
Cable	ft	3/16"x50'	7/32"x50'	1/4"x50'
	m	4.8mmx15.2m	5.5mmx15.2m	6.2mmx15.2m
Control	Solenoid / Indirect			

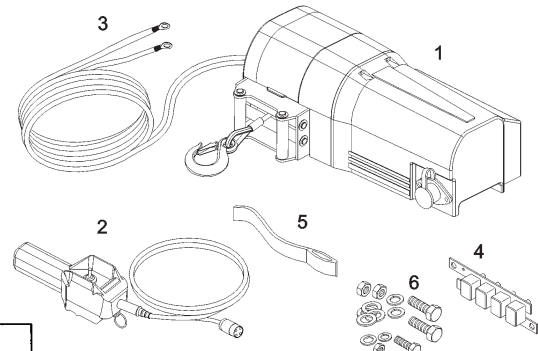

CHART 3. LINE SPEED

MODEL		RW2500/12.V2 RW2500/24.V2		RW3500/12.V2 RW3500/24.V2		RW4500/12.V2 RW4500/24.V2	
lb	kg	fpm	mpm	fpm	mpm	fpm	mpm
0	0	16.4	5.0	21.3	6.5	21.3	6.5
1,000	454	11.0	3.5	16.4	5.0	16.4	5.0
2,000	907	7.5	2.3	11.8	3.6	11.8	3.6
2,500	1,134	4.2	1.3	10.5	3.2	10.5	3.2
3,000	1,361			8.2	2.5	8.2	2.5
3,500	1,588	Stall		5.9	1.8	5.9	1.8
4,000	1,814					4.6	1.4
4,500	2,041			Stall		1.3	0.4

1. Winch
2. Remote switch
3. Battery cable
4. Circuit breaker assembly
5. Hand saver bar
6. Nuts, bolts and washers

CHART 4. AMP DRAW

MODEL		RW2500.V2		RW3500.V2		RW4500.V2	
lb	kg	12VDC	24VDC	12VDC	24VDC	12VDC	24VDC
0	0	30	10	25	10	25	10
1,000	454	80	55	110	55	110	55
2,000	907	150	115	200	100	210	95
2,500	1,134	200	140	230	115	240	110
3,000	1,361			260	140	270	120
3,500	1,588	Stall		300	180	290	140
4,000	1,814					310	155
4,500	2,041			Stall		330	170

CHART 5. CABLE WINDING CUMULATIVE LENGTH ON DRUM

MODEL	RW2500/12.V2 RW2500/24.V2		RW3500/12.V2 RW3500/24.V2		RW4500/12.V2 RW4500/24.V2	
	ft	m	ft	m	ft	m
Layer 1	10.4	3.2	9.0	2.7	8.0	2.4
Layer 2	22.0	6.7	19.8	6.0	17.4	5.3
Layer 3	35.8	10.9	32.3	9.8	28.1	8.6
Layer 4	50.0	15.2	46.5	14.2	41.0	12.5
Layer 5			50.0	15.2	50.0	15.2
Cable	3/16"x50'		7/32"x50'		1/4"x50'	
	4.8mmx15.2m		5.5mmx15.2m		6.2mmx15.2m	

CHART 6.

ROLLING LOAD CAPACITY AT DIFFERENT ANGLES ON FIRST LAYER OF CABLE.

The rolling weight performance shown includes a 12% rolling friction factor, and is based upon a hard level smooth surface. A 10% incline means a rise of 1m in 10m (fig C).

MODEL	RATED LINE PULL lb /kg	GRADIENT									
		0°(0%)		6°(10%)		11°(20%)		17°(30%)		45°(100%)	
		lb	kg	lb	kg	lb	kg	lb	kg	lb	kg
RW2500/12.V2 RW2500/24.V2	2,500 /1,134	20,833	9,450	11,167	5,065	8,101	3,675	6,141	2,786	3,157	1,432
RW3500/12.V2 RW3500/24.V2	3,500 /1,588	29,167	13,230	15,634	7,091	11,341	5,144	8,597	3,900	4,419	2,004
RW4500/12.V2 RW4500/24.V2	4,500 /2,041	37,500	17,010	20,101	9,118	14,581	6,614	11,053	5,014	5,682	2,577

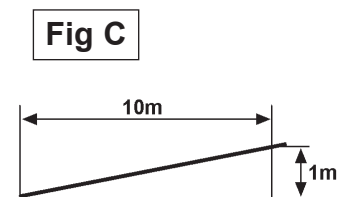

3. INSTALLATION

WARNING! Ensure you read and understand the safety instructions before installation.

3.1. MOUNTING THE WINCH ON VEHICLE.

3.1.1. Mounting.

- Choose the mounting location on the vehicle with care as it must be capable of supporting the pulling capacity of the winch (check with vehicle manufacturer for suitable mounting points). The mounting point must be capable of withstanding loads above the maximum rated capacity of the winch.
Ensure the mounting point is protected from deterioration or corrosion over the lifetime of the winch use. We recommend the mounting point is reinforced with steel plates and appropriate securing bolts.
- Before fixing, ensure the power supply cables will easily reach the battery.
- Use the washers, bolts and nuts to fix the winch to the mounting plate (see fig.1). The motor, drum and gear housing must be correctly aligned.
- Ensure there is an appropriate safe, dry, childproof location for the storage of the power cables and switches when not in use.

Fig 1

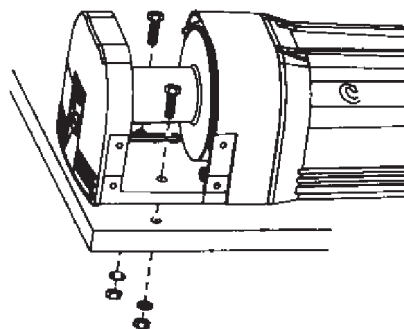

3.2. POWER SUPPLY CONNECTION.

3.2.1. Battery cable connection.

- Ensure connection to the battery is undertaken in accordance with the safe connecting and handling instructions for the battery.
- Ensure the power cables are safely routed away from the winch cable and will not be accidentally caught up in the winching process.

3. Connect the free end of the circuit breaker tightly to the positive (+) terminal of the supply battery (fig 4.A).
4. Connect BLACK cable (negative -) to a suitable earthing point on the vehicle frame (fig 4.B).

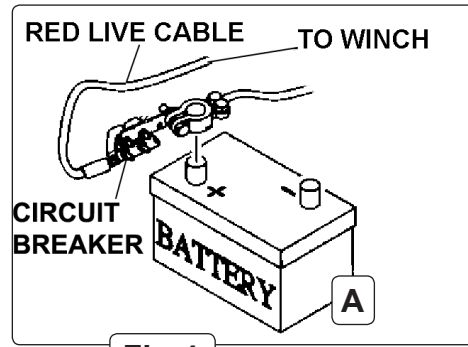
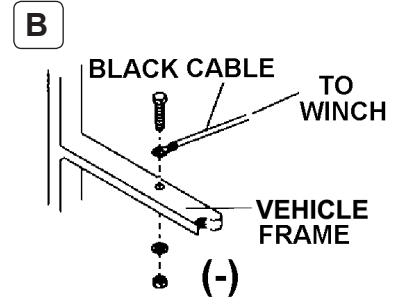

Fig 4



3.2.2. Cable specification.

Model	RW2500.V2	RW3500.V2	RW4500.V2
12 Volt	6AWG x 1.5m	6AWG x 1.5m	6AWG x 1.5m
24 Volt	8AWG x 1.5m	8AWG x 1.5m	8AWG x 1.5m

3.2.3. Switch connection.

WARNING! Always connect the remote control *before* connecting winch to battery. Disconnect winch from battery *before* disconnecting remote control.

To fit remote control, lift dust cover on the side of the winch and insert remote plug.

4. OPERATING INSTRUCTIONS

WARNING! Ensure you read and understand the safety instructions before use.

4.1. FREEWHEEL FUNCTION.

Note: The cable may be unwound under power by engaging the clutch and following steps in 4.2. below.

The cable may also be freewheeled and unwound by hand as follows:

The speed of unwinding the winch cable is controlled by a clutch.

For rapid unwinding proceed as follows:

1. Disconnect the winch from the electrical power supply.
2. Disengage the clutch by lifting the clutch lever (fig 5 & 6).
3. To unwind the cable, pull by hand using the hand saver bar and ensure that you wear appropriate safety gloves (fig 6).

Note: If the clutch lever will not lock into the 'Disengage' position, rotate the drum until it does.

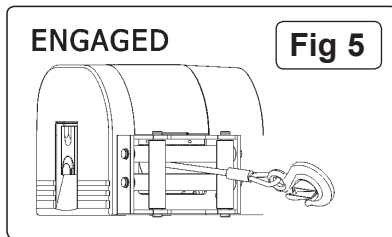

Fig 5

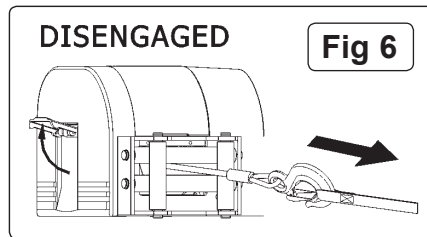

Fig 6

4.2. REMOTE SWITCH OPERATION.

WARNING! Always connect the remote control *before* connecting winch to battery. Disconnect winch from battery *before* disconnecting remote control.

To use the electrical remote switch control the clutch must be engaged as follows:

1. Connect remote control to winch (para. 3.2.3.)
2. Connect the winch to the power supply.
3. Engage the clutch by pushing the lever down (fig 5).
4. To extend the cable, move the toggle switch (fig 7) to the 'Out' position.
5. To winch the cable, move the toggle switch (fig 7) to the 'In' position.
6. Stop the winch by releasing the switch. The internal brake will hold the load in place.
7. Before disengaging cable from load, disconnect winch from power supply.

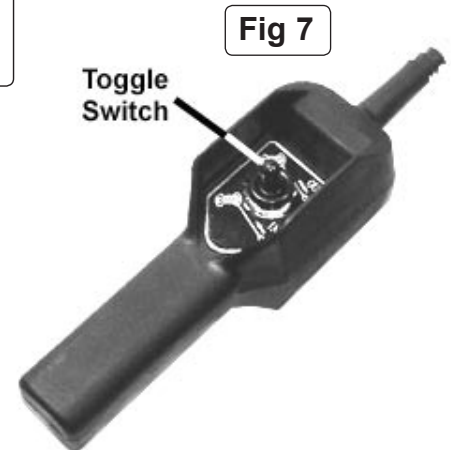

Fig 7

4.3. USE OF A PULLEY.

Additional pulling power may be obtained by use of a pulley block assembly. This almost doubles the effective pull and halves the pulling speed.

WARNING! When using a pulley, ensure the hook anchorage point (fig 8.C) will be capable of withstanding loads greater than the capacity of the winch.

Note that if winch and hook anchorage are both mounted on the same vehicle then this vehicle must be capable of withstanding at least twice the winch capacity.

DO NOT attach hook back onto winch body as winch mounting may fail. Always use a separate anchorage point.

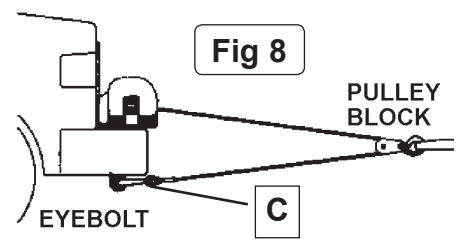

Fig 8

PULLEY BLOCK

EYEBOLT

C

5. MAINTENANCE

5.1. CHECK BEFORE EACH USE.

Before each use check the following to ensure all parts are sound and in good working order and condition:

Mounting/fixing bolts and nuts, motor for correct operation, steel winch cable for fraying, kinks, broken strands or distortion, operating switches and cables, power supply cables, clutch and brake to ensure loads will hold when switch is released. If any parts are broken or damaged, do not use the winch, but take immediate action to repair. With the exception of the items below, all service and maintenance must be undertaken by fully qualified personnel.

5.2. LUBRICATION.

The winch is a sealed unit and has been fully lubricated at the time of manufacture. No additional lubrication should be necessary.

5.3. CABLE REPLACEMENT.

Only use a new cable of the same rating as the one supplied with the winch. **DO NOT** use a smaller or larger cable and ensure the cable is made of steel wire.

1. Unwind the entire cable from the winch drum. Undo the retaining grub screw and remove cable from the drum.
2. Insert the replacement cable through outlet guides (fig 9. A) under and around drum securing with grub screw (B).
3. Attach the cable to the hook by returning it through the hook eye and tightly secure with 2 cable clamps.
4. Check that the cable winds smoothly and correctly before use.

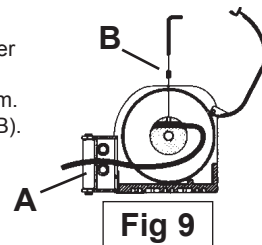

NOTE: It is our policy to continually improve products and as such we reserve the right to alter data, specifications and component parts without prior notice.

IMPORTANT: No liability is accepted for incorrect use of this product.

WARRANTY: Guarantee is 12 months from purchase date, proof of which will be required for any claim.

INFORMATION: For a copy of our latest catalogue and promotions call us on 01284 757525 and leave your full name and address, including postcode.



Sole UK Distributor, Sealey Group,
Kempson Way, Suffolk Business Park,
Bury St. Edmunds, Suffolk,
IP32 7AR



01284 757500



www.sealey.co.uk



01284 703534



sales@sealey.co.uk