



ROADSTART® EMERGENCY JUMP STARTER

3100/1550A 12/24V

MODEL NO: **RS105B.V2**

Thank you for purchasing a Sealey product. Manufactured to a high standard, this product will, if used according to these instructions, and properly maintained, give you years of trouble free performance.

IMPORTANT: PLEASE READ THESE INSTRUCTIONS CAREFULLY. NOTE THE SAFE OPERATIONAL REQUIREMENTS, WARNINGS & CAUTIONS. USE THE PRODUCT CORRECTLY AND WITH CARE FOR THE PURPOSE FOR WHICH IT IS INTENDED. FAILURE TO DO SO MAY CAUSE DAMAGE AND/OR PERSONAL INJURY AND WILL INVALIDATE THE WARRANTY. KEEP THESE INSTRUCTIONS SAFE FOR FUTURE USE.



Refer to instructions



Warning!



Wear eye protection



Warning corrosive substance



Wear protective gloves



Electrical shock hazard



Keep in dry area protect from rain

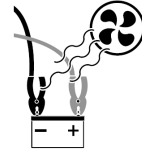

Use in well ventilated areas



Keep away from sources of ignition

1. SAFETY

IMPORTANT: To reduce the risk of a battery explosion, follow these instructions and those published by the battery manufacturer and the manufacturer of any equipment you intend to use in the vicinity of the battery. Remember to review warning marks on all products and on engines. Modern vehicles contain extensive electronic systems. Check with the vehicle manufacturer for any specific instructions regarding the use of this type of equipment on each vehicle. No liability will be accepted for damage/injury where this product is not used in accordance with all instructions.

1.1. SAFETY INSTRUCTIONS

- ✓ Wear safety eye protection and protective clothing. Avoid touching eyes while working with a battery.
 - ✓ Wash immediately with soap and water if battery acid contacts skin or clothing. If acid enters eye, flush eye immediately with cool, clean running water for at least 15 minutes and seek immediate medical attention.
 - ✓ Remove personal metallic items such as rings, bracelets, necklaces and watches.
 - ✓ Keep the unit in good working order and condition. Replace damaged parts immediately.
 - ✓ Use only recommended parts. To use unapproved parts may be dangerous and will invalidate your warranty.
 - ✓ The Roadstart must only be opened and checked by qualified service personnel. **DO NOT** disassemble the unit for any reason.
 - ✓ Keep children and unauthorised persons away from the work area.
 - ✓ Keep work area clean and tidy and free from unrelated materials. Ensure that there is adequate lighting.
 - ✓ If the Roadstart receives a sharp knock or blow, it must be checked by a qualified service agent before being used.
 - ✓ **NOTE:** If the internal battery is leaking **DO NOT** use and replace battery immediately.
 - ✓ Isolate the spillage and clean appropriately.
 - ☐ **WARNING!:** Battery acid can cause skin damage/burns, respiratory issues, eye damage and throat irritation so please ensure all precautions are taken place.
 - * **DO NOT** smoke or allow a spark, or flame in the vicinity of the battery or engine.
 - * **DO NOT** drop any metal item onto the battery as it may spark or short circuit the battery, which could cause an explosion.
 - * **DO NOT** use Roadstart to recharge dry cell batteries that are commonly used with home appliances.
 - * **DO NOT** charge or boost a frozen battery.
 - * **DO NOT** use attachments other than those recommended.
 - * **DO NOT** pull or carry the unit by its cables and **DO NOT** pull the negative and positive clamps from the battery terminals.
 - * **DO NOT** operate in vicinity of flammable liquids or gases.
 - * **DO NOT** recharge the unit with a charger / cables that are damaged. Replace immediately.
 - * **DO NOT** use this product to perform a task for which it is not designed.
 - * **DO NOT** store the unit in damp or wet locations or where the temperature may exceed 50°C.
 - * **DO NOT** submerge the unit in water.
 - * **DO NOT** use whilst under the influence of drugs, alcohol or intoxicating medication.
 - * **DO NOT** leave the unit in a totally discharged state for an extended period of time as this may result in permanent damage.
 - * **DO NOT** cross-connect the power leads from the Roadstart to battery. Ensure positive is to positive and negative is to negative. Children from age 8 years and above, persons with reduced physical, sensory, or mental capabilities those with lack of experience and knowledge can use the appliance, if they have been given supervision or instruction concerning use of the appliance in a safe way to understand the hazards involved.
 - * Children shall **NOT** play with the appliance.
 - * Cleaning and user maintenance on the appliance shall not be made by children without supervision.
 - ✓ The appliance shall be disconnected from its power source during service and when replacing parts and, if that the removal of the plug is foreseen, it shall be clearly indicated that the removal of the plug has to be such that an operator can check from any of the points to which he/she has access that the plug remains removed.
 - ✓ Ensure that the unit is fully charged before storage. Keep the unit fully charged on a regular basis.
- ### 1.2. ELECTRICAL SAFETY (with respect to mains chargers)
- ☐ **WARNING!** It is the user's responsibility to check the following:
 - ✓ Check all electrical equipment and appliances to ensure that they are safe before using. Inspect power supply leads, plugs and all electrical connections for wear and damage. Sealey recommend that an RCD (Residual Current Device) is used with all electrical products.
 - ✓ **Electrical safety information.** It is important that the following information is read and understood:
 - ✓ Ensure that the insulation on all cables and on the appliance is safe before connecting it to the power supply.

- ✓ Regularly inspect power supply cables and plugs for wear or damage and check all connections to ensure that they are secure.
- ✓ **Important:** Ensure that the voltage rating on the appliance suits the power supply to be used and that the plug is fitted with the correct fuse.
- ✗ **DO NOT** pull or carry the appliance by the power cable.
- ✗ **DO NOT** pull the plug from the socket by the cable.
- ✗ **DO NOT** use worn or damaged cables, plugs or connectors. Ensure that any faulty item is repaired or is replaced immediately by a qualified electrician.
- ✓ If the cable or plug is damaged during use, switch off the electricity supply and remove from use.
- ✓ **Ensure that repairs are carried out by a qualified electrician.**
- ✓ Ensure that the insulation on all cables and the product itself is safe before connecting to the mains power supply.
- ✓ Ensure that cables are always protected against short circuit and overload.

2. INTRODUCTION

Composite case with integral battery clamp storage and carry handle. Suitable for starting 12V vehicles with 8-cylinder petrol engines up to 6L and 8-cylinder diesel engines up to 4.8L. Also suitable for starting 24V vehicles with 6 cylinder diesel engines up to 3L. Front panel displays internal battery charge level and includes an integral LED worklight. Reverse polarity and short circuit protection. Mains charger with automatic cut-off prevents damage to battery whilst charging. Inbuilt fuseable link protection system. Fitted with two 12V power sockets that will accept any 12V device with a vehicle accessory socket plug.

3. SPECIFICATION

Model No: RS105B.V2
 Auxiliary Output:..... 2 x 12V Port
 Cable/clamp length: 0.7m
 Cold Cranking Amps: 12V/24V - 600A/300A
 Fuse Rating: 650A
 Peak Amps:..... 12V/24V - 3100A/1550A
 Power Supply Cable Length:..... 1m
 Rated Capacity:44Ah
 Voltage:..... 12V/24V
 Weight:..... 14.5kg

Charger Specification

Model No.: RS1B.CHARGER
 Input:..... 230V~50Hz 0.3A
 Output:.....15V 0.8A
 Plug Type:..... 3-Pin BS

4. OPERATION

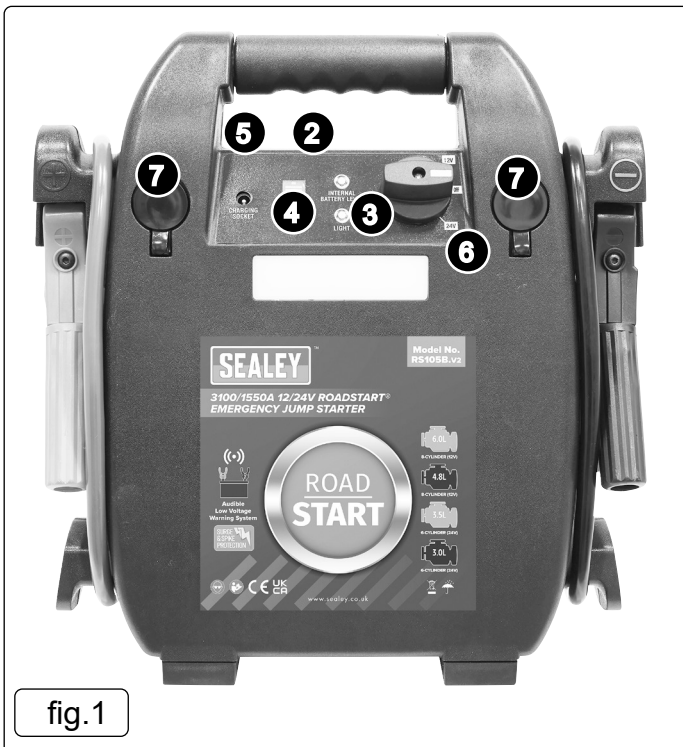

fig.1

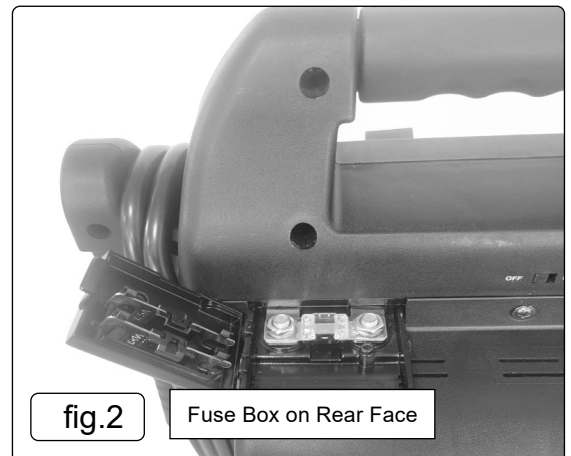

fig.2

Fuse Box on Rear Face

Item	Description
1	On/Off/Selection switch
2	Internal battery level
3	Worklight switch
4	Internal battery level LED display
5	Charge socket
6	Worklight
7	12V power socket
8	USB switch (On rear face, not shown)
9	USB socket (On rear face, not shown)

4.1. JUMP STARTING

NOTE: Before first use, charge unit for an initial 72 hour period in a well ventilated area.

Suitable for use on any type of 6 cell Lead Acid Battery.

* **DO NOT** use for nonrechargeable batteries.

- 4.1.1. Ensure both the ignition of vehicle to be started and the Roadstart main power switch is switched off before any connections are made to the battery.
- 4.1.2. First connect the RED (+) alligator clamp of the Roadstart to the RED (+) positive battery terminal of the vehicle.
- 4.1.3. Connect the BLACK(-) alligator clamp of the Roadstart to a non-moving metal part of the engine or chassis (avoid connecting to fuel lines).
- 4.1.4. Switch the Roadstart main switch to ON position – either 12V or 24V selection depending on vehicle system required.
- 4.1.5. Once Roadstart main power switch is ON (12V or 24V setting), leave for approximately 30 seconds.
- 4.1.6. With the Roadstart still connected and switched on, turn the vehicle ignition and crank the engine.
 - * **DO NOT** crank the engine for any more than 5 seconds at a time.
- 4.1.7. If the engine fails to start, wait for at least 2 minutes before trying again to avoid overloading the unit.
- 4.1.8. Once the engine is running, switch the Roadstart power switch to the OFF position. Disconnect the BLACK(-) Negative clamp from the vehicle first, and return the cable to its storage position on the Roadstart unit.
- 4.1.9. Disconnect the RED (+) Positive clamp last, and return the cable to its storage position on the Roadstart unit. As soon as possible, connect the Roadstart to the supplied 230V AC Charger and recharge the unit to maintain battery life.

4.2. LED MULTI-FUNCTION DISPLAY fig.1/fig.3.

The LED Battery display on the front panel shows several important pieces of information.

- 4.2.1. With Roadstart main switch in ON position (12V or 24V setting), pressing display button will show Internal Battery capacity. Use this to check if recharging is required. When charging the unit, turn the main switch to 12V position ONLY for correct charging. If the main switch is turned to 24V or to the off position to charge the internal battery, the red LED will flash and a continuous audible tone will be heard.
- 4.2.2. Solid red led indicator light on the mains charger, when recharging is underway (to see battery bars press display button - display will go out after a few seconds but red LED light on mains charger, will stay lit).
- 4.2.3. Green indicator light on the mains charger, signifies fully charged. (A press of the display button will also illuminate the battery bar display.)
- 4.2.4. **Low Voltage alert** – When the main Roadstart switch is in the on position (either 12V or 24V setting), the red LED indicator at the top of the battery display will be flashing every 25 seconds and a single beep will be heard every 25 seconds, informing the user that recharging is required. This will occur at approximately 60% remaining charge.
- 4.2.5. When the unit is outputting big current for a long time, the temperature protection will cut output for a while, the red LED indicator at the top of the battery will flash, until the temperature cools down. Once it is at a sufficiently low temperature, it will restore output.

4.3. BATTERY CAPACITY INDICATING BAR

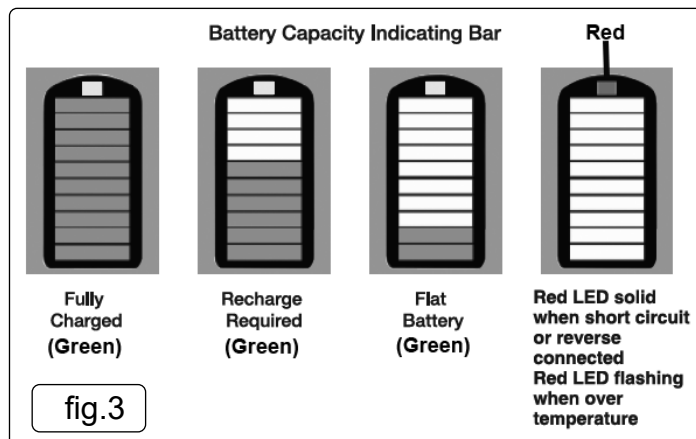

4.4. OPERATION AS A PORTABLE POWER SUPPLY

4.4.1. 12V ACCESSORY SOCKETS:

This unit is fitted with 2 x 12V power accessory sockets. To use these output sockets, plug in your device and power will output as soon as a connection is made. These sockets combined are rated at 15 Amps. Please do not exceed these rated limits to prevent overloading the internal circuitry. Ensure the rubber dust covers are placed over the sockets when not in use to prevent dust or moisture from entering the socket.

4.5. LED EMERGENCY LIGHT

Depress the light switch once to turn the light on. Depress the switch again to turn the light off.

4.6. RECHARGING THE ROADSTART UNIT

- 4.6.1. When charging, the battery must be placed in a well-ventilated area.
 - **WARNING!** For the purposes of recharging the battery, only use the detachable supply unit provided with this appliance.
- 4.6.2. For maximum battery life it is recommended that this unit be kept fully charged at all times. Use only the supplied charger, as it is automatic and does not require monitoring of the charging process. Failure to do so could damage the unit, and will invalidate the warranty.
- 4.6.3. When charging turn the power switch to 12V. If the power switch is on, off or 24V the unit will not charge and will start beeping as a warning.
- 4.7. **TO PROLONG BATTERY LIFE:**
 - 4.7.1. Recharge the unit every 3 months even if it isn't used.
 - 4.7.2. Recharge the unit as soon as possible after use.
 - 4.7.3. Avoid storage in extreme temperatures where possible (above 50 degrees Celsius and below 0 degrees Celsius).
 - 4.7.4. Never store the unit in a discharged state.

4.8. BATTERY DISPOSAL:

The lead acid battery contained in this Roadstart should be recycled once expired (consult your local authority requirements for safe disposal of lead acid batteries).

The battery must be removed from the appliance before it is scrapped.

The appliance must be disconnected from the charger and supply mains charger when removing the battery.

The battery is to be disposed of safely.

To remove the battery, remove the screws surrounding the back housing then remove the rear panel to expose the battery cavity.

Unscrew the two hex head screws on the battery terminals and then gently slide the battery out of its cavity. Once the battery is out, insulate the battery terminals with strips of electrical tape to prevent accidental short circuits.

5. INBUILT SAFETY SYSTEMS

- 5.1. This Roadstart is fitted with sophisticated electronic safety systems to protect the unit and the connected battery in the result of accidental user error. Even with these protection systems in place, extreme care should be taken with the correct identification of the system voltage and the batteries being jump started:
- 5.1.1. **Short circuit protection:** In the event of accidentally touching the Positive and Negative clamps together, the fusible link (fig.2) will be blown which will shut off output power thereby preventing a dangerous overload situation.
- 5.1.2. **Reverse Polarity Protection:** If the Roadstart is accidentally connected in the reverse polarity when jump starting, the fusible link (fig.2) will be blown. Power will not output when the fusible link is blown, simply replace the broken fusible link with one of the spares (see Section 5.1.6) and correct the polarity of the connection before attempting to use again.
- 5.1.3. **24V battery connection protection (when switched to 12V):** In the event of accidental connection to a 24V battery system, the fusible link (fig.2) will be blown. Power will not output when the fusible link is blown, simply replace the broken fusible link with one of the spares before attempting to use again. Even though this protection will protect the Roadstart from catastrophic failure, extreme care should be taken by the user to correctly identify the type of battery to be jump started and the operating voltage of the system.
- 5.1.4. **Over load and over temperature protection:** When using the clamps to output power, if the load too big or the use time is too long, the fusible link (fig.2) will be blown. Power will not output when the fusible link is blown, simply replace the broken fusible link with one of the spares (see Section 5.1.6) before attempting to use again.
- 5.1.5. **Low Voltage alert:** A single beep will be heard every 25 seconds when recharging is required, or approximately 60% remaining charge. This will occur only when the main power switch is switched ON.
- NOTE:** To change a blown fuse, switch the unit off and allow 5 minutes to cool. Remove clamps from the battery, unplug the unit from the power supply and unscrew the cover (fig.2). Remove the hexagonal nuts and lift out the fuse ensuring it is not hot.



ENVIRONMENT PROTECTION

Recycle unwanted materials instead of disposing of them as waste. All tools, accessories and packaging should be sorted, taken to a recycling centre and disposed of in a manner which is compatible with the environment. When the product becomes completely unserviceable and requires disposal, drain any fluids (if applicable) into approved containers and dispose of the product and fluids according to local regulations.



REGISTER YOUR PURCHASE HERE



WEEE REGULATIONS

Dispose of this product at the end of its working life in compliance with the EU Directive on Waste Electrical and Electronic Equipment (WEEE). When the product is no longer required, it must be disposed of in an environmentally protective way. Contact your local solid waste authority for recycling information.



BATTERY REMOVAL

Under the Waste Batteries and Accumulators Regulations 2009, Jack Sealey Ltd are required to inform potential purchasers of products containing batteries (as defined within these regulations), that they are registered with Valpak's registered compliance scheme. Jack Sealey Ltd Batteries Producer Registration Number (BPRN) is BPRN00705.

Note: It is our policy to continually improve products and as such we reserve the right to alter data, specifications and component parts without prior notice. Please note that other versions of this product are available. If you require documentation for alternative versions, please email or call our technical team on technical@sealey.co.uk or 01284 757505.

Important: No Liability is accepted for incorrect use of this product.

Warranty: Guarantee is 12 months from purchase date, proof of which is required for any claim.

Sealey Group, Kempson Way, Suffolk Business Park, Bury St Edmunds, Suffolk. IP32 7AR



01284 757500



sales@sealey.co.uk



www.sealey.co.uk