



# 2.5 TONNE ALUMINIUM/STEEL TROLLEY JACK WITH ROCKET LIFT

MODEL NO: **RJAS2500.V4**

Thank you for purchasing a Sealey product. Manufactured to a high standard, this product will, if used according to these instructions, and properly maintained, give you years of trouble free performance.

**IMPORTANT:** PLEASE READ THESE INSTRUCTIONS CAREFULLY. NOTE THE SAFE OPERATIONAL REQUIREMENTS, WARNINGS & CAUTIONS. USE THE PRODUCT CORRECTLY AND WITH CARE FOR THE PURPOSE FOR WHICH IT IS INTENDED. FAILURE TO DO SO MAY CAUSE DAMAGE AND/OR PERSONAL INJURY AND WILL INVALIDATE THE WARRANTY. KEEP THESE INSTRUCTIONS SAFE FOR FUTURE USE.



Refer to instructions



Wear safety footwear

## 1. SAFETY

- ✓ Ensure the jack is in sound condition and good working order. Take action for immediate repair or replacement of damaged parts. Use genuine parts only. The use of improper parts may be dangerous and will invalidate the warranty.
- ✓ Locate the jack in a suitable, well lit working area.
- ✓ Keep working area clean and tidy and free from unrelated materials. Use jack on level and solid ground, preferably concrete.
- ✓ Avoid tarmac/adam as jack may sink in.
- ✓ Chock wheels of vehicle.
- ✓ Ensure the vehicle handbrake is engaged, engine is switched off and transmission is in gear (or "PARK" if automatic).
- ✓ Ensure minimum distance of 0.5m between vehicle and static objects such as doors, walls, etc., to allow for vehicle tilting.
- ✓ Ensure all non-essential persons keep a safe distance whilst the jack is in use.
- ✓ Ensure there are no passengers in the vehicle.
- ✓ Place jack under only those lifting points recommended by vehicle manufacturer (see vehicle handbook).
- ✓ Check that the lifting point is stable and centred on the jack saddle.
- ✓ Ensure the jack wheels are free to move and that there are no obstructions.
- ▲ **DANGER:** Use the jack for lifting only, NOT for supporting the lifted load.
- ✓ Ensure there are no persons or obstructions beneath the vehicle before lowering.
- ✓ Use suitable axle stands under the vehicle before proceeding with any task.
- ✓ Use a qualified person to lubricate and maintain the jack.
- ✗ **DO NOT** operate the jack if damaged.
- ✗ **DO NOT** allow untrained persons to operate the jack.
- ✗ **DO NOT** exceed the rated capacity of the jack.
- ✗ **DO NOT** allow the vehicle to move during lifting or lowering, or use the jack to move the vehicle.
- ✗ **DO NOT** jack vehicle if there is a risk of spillage of fuel, battery acid, or other dangerous substances.
- ✗ **DO NOT** work under the vehicle until appropriately rated axle stands have been correctly positioned.
- ✗ **DO NOT** use the jack for purposes other than that for which it is intended.
- ✓ Use hydraulic jack oil only. (Sealey Part No: HJO500MLS or HJO5LS)
- ✗ **DO NOT** adjust the safety overload valve.
- ✓ When not in use store jack, fully lowered, in a safe, dry, childproof area.

## 2. INTRODUCTION

Made primarily for the motor racing enthusiast, this jack weighs in at just over 25kg. Mix of steel and aluminium not only makes this jack lightweight but incredibly strong. Large saddle with jacking pad. Rocket Lift with twin piston design enables saddle to be brought up to jacking point with minimal pumps. Lifting bars are fitted either side of the anodised aluminium chassis enabling fast, lightweight pick-up.

## 3. SPECIFICATION

Model No:..... **RJAS2500.V4**  
Applicable Standards: ..... EN1494  
Capacity:..... 2.5tonne  
Consumable Parts: ..... Rubber Jack Pad - JP11  
Length:..... 659mm  
Maximum Chassis Height: ..... 165mm  
Maximum Saddle Height: ..... 465mm  
Minimum Saddle Height: ..... 100mm

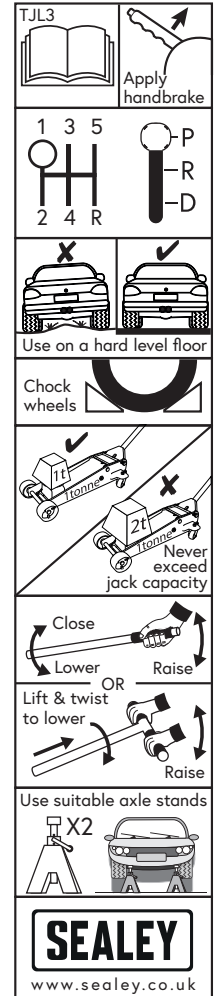

## 4. ASSEMBLY

- 4.1. The jack comprises the following parts:  
Aluminium/Steel chassis.  
Two-part quick connect pumping handle.
- 4.2. Insert the upper handle into the lower handle, until the push button locates in the lower handle hole (fig.1).
- 4.3. Undo the handle socket screw (B) until it no longer protrudes into the handle socket (fig.2).
- 4.4. Insert the pump handle into the handle socket hole, engaging the square drive of the release valve.
- 4.5. Ensure that the handle is correctly inserted into the socket, then tighten the handle socket screw (B).

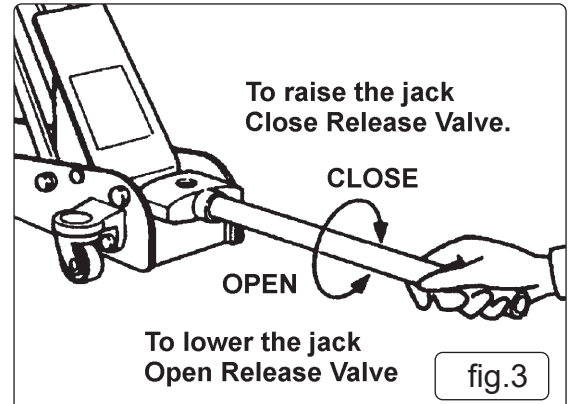
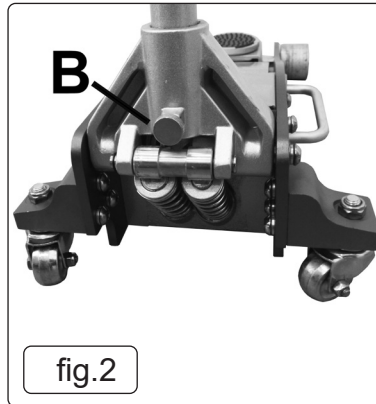
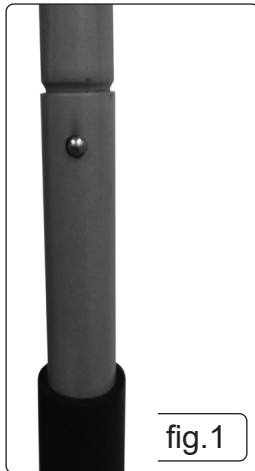

### 4.6. PURGE HYDRAULIC SYSTEM numbers in brackets refer to attached Parts Diagram

- 4.6.1. Open the release valve. Pump the handle several times, quickly. Push the edge of the oil filler plug (4) located on top of the hydraulic ram (1) to expel air.
- 4.6.2. Repeat if necessary.

## 5. OPERATION

- ❑ **WARNING!** Before use ensure you have read, understood and apply Section 1 safety instructions.  
**IMPORTANT:** Before use, the operator is to visually inspect the jack for cracked welds, damaged or missing parts or hydraulic leaks.

### 5.1. RAISING A VEHICLE

- 5.1.1. Ensure that the jack and the vehicle are on a hard, level surface.
- 5.1.2. Always ensure that the vehicle handbrake is engaged and that the vehicle wheels are chocked.
- 5.1.3. Consult the vehicle manual to determine the location of jacking points. Position the jack under a suitable lifting point.
- 5.1.4. Turn the release valve clockwise, to the closed position (fig.3). **DO NOT** over-tighten.
- 5.1.5. Raise the vehicle to the desired height by pumping the handle up and down. Operator must watch the jack and the load during all movements.
- 5.1.6. Place axle stands beneath the locations recommended by the vehicle manufacturer.
- 5.1.7. Turn the release valve slowly counter-clockwise to lower the vehicle on to the axle stands.

### 5.2. LOWERING A VEHICLE

- 5.2.1. Turn the release valve clockwise to the closed position.
- 5.2.2. Pump the handle to raise the vehicle off the axle stands.
- 5.2.3. Remove the axle stands from beneath the vehicle.
- 5.2.4. Turn the release valve slowly counter-clockwise to lower the vehicle to the ground.

**NOTE:** When not in use, ALWAYS leave the saddle and ram fully retracted.

## 6. MAINTENANCE

**IMPORTANT:** Only fully qualified personnel should attempt maintenance or repair.

### 6.1. MONTHLY MAINTENANCE

Lubrication is critical to jacks, since they support heavy loads. Any restriction due to dirt or rust can cause either slow jack movement, or extremely rapid jerks, causing damage to the internal components. To keep the jack well lubricated, carry out the following steps.

- 6.1.1. Lubricate the ram, the linkages and the saddle and pump mechanism with light oil.
- 6.1.2. Grease the wheel bearing and axles.
- 6.1.3. Keep all jack surfaces and warning labels clean.
- 6.1.4. Check and maintain the ram oil level (Section 6.3).

### 6.2. THREE MONTHLY MAINTENANCE

- 6.2.1. At three monthly intervals, check the ram for any signs of rust or corrosion. Clean the ram as required and wipe with an oil cloth.

### 6.3. CHECK OIL LEVEL

- 6.3.1. Fully retract the ram by turning the release valve counter-clockwise.
- 6.3.2. With the jack in a level position, remove the oil filler plug, (46 on Parts Diagram).
- 6.3.3. The oil should be level with the bottom of the oil filler hole. If it is not top up with clean hydraulic jack oil. (Sealey Part No: HJO500MLS or HJO5LS)
- 6.3.4. Replace the oil filler plug (46) and check the jack operation.
- 6.3.5. Purge air from the hydraulic unit as required. Refer to Section 4.

**NOTE:** Always store the jack in the fully lowered position. This will protect critical areas from excessive corrosion.

**IMPORTANT: NO RESPONSIBILITY IS ACCEPTED FOR INCORRECT USE OF THIS PRODUCT.**

Owing to their size and weight, hydraulic products should ideally be repaired by local service agents. We have service / repair agents in most parts of the UK. Before returning your product please call our technical helpline on 01284 757505 for advice and trouble shooting guidance.

If the jack is under guarantee please contact your stockist.

## 7. TROUBLESHOOTING

PROBLEM	CAUSE	REMEDY
Jack will not lift to full height	Oil level low	Check / top up oil level
Jack will not hold the load	Release valve not closing Hydraulic jack oil is contaminated Pump valves not sealing	Contact authorised service agent
Lift arm will not lower	Cylinder ram binding Parts worn Internal component damage Broken or unhooked return spring Lift arm linkage either bent or binding	Contact authorised service agent
Jack feels spongy when lifting	System requires purging	Refer to air purge procedure at Section 4.6



### ENVIRONMENT PROTECTION

Recycle unwanted materials instead of disposing of them as waste. All tools, accessories and packaging should be sorted, taken to a recycling centre and disposed of in a manner which is compatible with the environment. When the product becomes completely unserviceable and requires disposal, drain any fluids (if applicable) into approved containers and dispose of the product and fluids according to local regulations.



**Note:** It is our policy to continually improve products and as such we reserve the right to alter data, specifications and component parts without prior notice. Please note that other versions of this product are available. If you require documentation for alternative versions, please email or call our technical team on [technical@sealey.co.uk](mailto:technical@sealey.co.uk) or 01284 757505.

**Important:** No Liability is accepted for incorrect use of this product.

**Warranty:** Guarantee is 36 months from purchase date, proof of which is required for any claim.

Sealey Group, Kempson Way, Suffolk Business Park, Bury St Edmunds, Suffolk. IP32 7AR



01284 757500



[sales@sealey.co.uk](mailto:sales@sealey.co.uk)



[www.sealey.co.uk](http://www.sealey.co.uk)