



1.5 TONNE ALUMINIUM/STEEL TROLLEY JACK WITH ROCKET LIFT

MODEL NO: **RJAS1500.V3**

Thank you for purchasing a Sealey product. Manufactured to a high standard, this product will, if used according to these instructions, and properly maintained, give you years of trouble free performance.

IMPORTANT: PLEASE READ THESE INSTRUCTIONS CAREFULLY. NOTE THE SAFE OPERATIONAL REQUIREMENTS, WARNINGS & CAUTIONS. USE THE PRODUCT CORRECTLY AND WITH CARE FOR THE PURPOSE FOR WHICH IT IS INTENDED. FAILURE TO DO SO MAY CAUSE DAMAGE AND/OR PERSONAL INJURY AND WILL INVALIDATE THE WARRANTY. KEEP THESE INSTRUCTIONS SAFE FOR FUTURE USE.



Refer to instructions



Wear safety footwear

1. SAFETY

- ❑ **WARNING!** Please note that the handle socket of this jack is retained under tension and must be released before use. Caution should be taken when releasing, as the handle socket will suddenly raise to its upright position if not controlled.
- ✓ The user shall work only in accordance with this instruction manual.
- ✓ The operator shall be provided with all necessary information about training and about pumping and translating forces.
- ✓ Ensure the jack is in sound condition and good working order. Take action for immediate repair or replacement of damaged parts. Use genuine parts only. **DO NOT** modify the jack. The use of non-genuine parts may be dangerous and will invalidate the warranty.
- ✓ Locate the jack in a suitable, well lit working area.
- ✓ Keep working area clean and tidy and free from unrelated materials. Use jack on level and solid ground, preferably concrete. Avoid tarmac as jack may sink in.
- ✓ Chock wheels of vehicle.
- ✓ Ensure the vehicle handbrake is engaged, engine is switched off and transmission is in gear (or "PARK" if automatic).
- ✓ Ensure minimum distance of 0.5m between vehicle and static objects such as doors, walls, etc. to allow for vehicle tilting.
- ✓ Ensure all non-essential persons keep a safe distance whilst the jack is in use.
- ✓ Ensure there are no passengers in the vehicle.
- ✓ It is necessary that the operator can watch the lifting device and the load during all movements.
- ✓ Place jack under only those lifting points recommended by vehicle manufacturer (see vehicle handbook).
- ✓ Check that the lifting point is stable and centred on the jack saddle.
- ✓ Ensure the jack wheels are free to move and that there are no obstructions.
- ▲ **DANGER:** Use the jack for lifting only, NOT for supporting the lifted load.
- ✓ Ensure there are no persons or obstructions beneath the vehicle before lowering.
- ✓ It is not allowed to work under the raised load until it is secured by suitable means. Use suitable axle stands under the vehicle before proceeding with any task.
- ✓ Use a qualified person to lubricate and maintain the jack.
- ✓ Ensure that only hydraulic jack oil is used in the jack.
- ✗ **DO NOT** operate the jack if damaged.
- ✗ **DO NOT** allow untrained persons to operate the jack.
- ✗ **DO NOT** operate the jack when tired or under the influence of drugs, alcohol or intoxicating medication.
- ✗ **DO NOT** exceed the rated capacity of the jack.
- ✗ **DO NOT** allow the vehicle to move during lifting or lowering, or use the jack to move the vehicle.
- ✗ **DO NOT** jack vehicle if there is a risk of spillage of fuel, battery acid, or other dangerous substances.
- ✗ **DO NOT** work under the vehicle until appropriately rated axle stands have been correctly positioned.
- ✗ **DO NOT** use the jack for purposes other than that for which it is intended.
- ✗ **DO NOT** top up hydraulic system with brake fluid. Use hydraulic jack oil only. (Sealey Part No: HJO500MLS or HJO5LS)
- ✗ **DO NOT** adjust the safety overload valve.
- ✓ When not in use store jack, fully lowered, in a safe, dry, childproof area.
- ✓ If more than 400N of effort is generated in lifting, the efforts shall be lowered by an additional person.
- ✓ Jacks shall be maintained and repaired in accordance with the manufacturer's instructions. Such maintenance and repair shall be carried out by qualified persons.
- ✓ No modifications shall be carried out which adversely affect the compliance of the jack with the standard.
- ✓ Check the state of the markings and that the markings remain as the initial one.

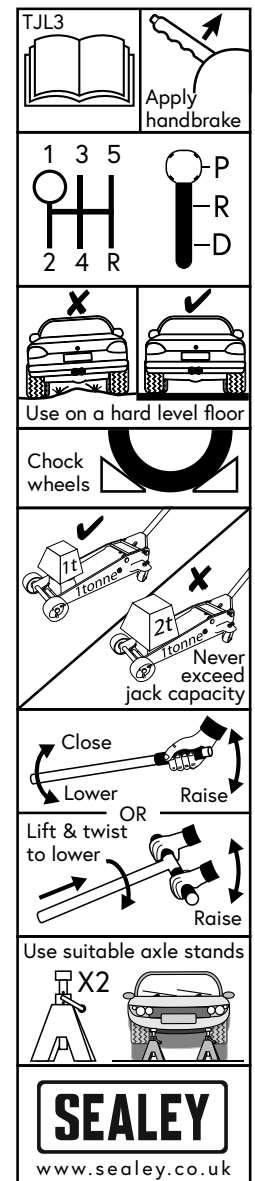

2. INTRODUCTION

Made primarily for the motor racing enthusiast, this jack weighs in at just 14.74kg. Mix of steel and aluminium not only makes this jack lightweight but incredibly strong. Large saddle with jacking pad. Rocket Lift with twin piston design enables saddle to be brought up to jacking point with minimal pumps. Features a lifting bar for fast, lightweight pick-up.

3. SPECIFICATION

Model No:..... **RJAS1500.V3**
Capacity:..... 1.5 Tonne
Length:..... 553mm
Maximum Chassis Height: 134mm

Maximum Saddle Height: 360mm
Minimum Saddle Height: 90mm
Replacement Rubber Jack Pad:..... JP11

4. SET-UP

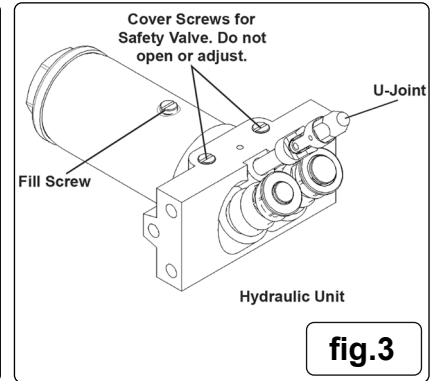
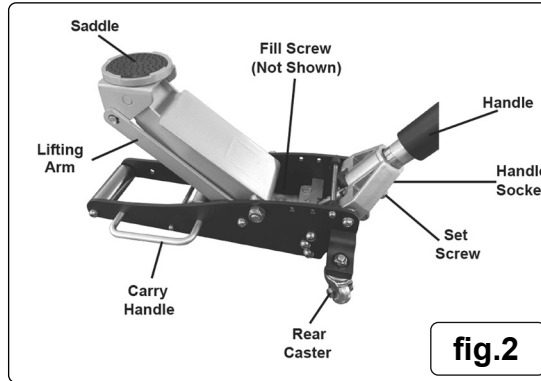

4.1. RELEASING THE RETAINING WEDGE (FIG.1)

- 4.1.1. Seek assistance from a second person if required.
- 4.1.2. Insert the lower handle section into the handle socket and secure with the retaining bolt to aid in releasing pressure in the handle socket.
- 4.1.3. Push down on the handle and hold down while removing the retaining wedge that is securing the handle socket in the down position.
- 4.1.4. Remove the wedge.
- 4.1.5. Gently and in a controlled manner slowly allow the lower handle section and handle socket to raise to their upright position.
- 4.1.6. Attach the upper handle to the lower handle.
- 4.1.7. Tighten the set screw.

4.2. ADDING HYDRAULIC FLUID

- 4.2.1. Remove the Fill Screw. **DO NOT** remove or loosen Safety Valve Cover Screws.
- 4.2.2. Add high grade hydraulic fluid (sold separately) slowly until the fluid reaches 1/4" (6.5mm) below the top of the Fill Port. (Fig.3).
NOTE: DO NOT touch the Handle when adding hydraulic fluid.
- 4.2.3. Replace Fill Screw.

4.3. BLEEDING

NOTE: BEFORE EACH USE OR IF JACK PERFORMANCE DECREASES, check for excessive air and proper hydraulic fluid level in Jack. If Jack appears not to be working properly, it may be necessary to purge its hydraulic system of excessive air as follows:

- 4.3.1. Loosen the Fill Screw.
- 4.3.2. Twist the Handle counter-clockwise to open the Valve.
- 4.3.3. Check fluid level and, if necessary, top off according to Adding Hydraulic Fluid below.
- 4.3.4. Twist the Handle clockwise to close the Valve, then pump the Handle quickly several times.
- 4.3.5. Replace Fill Screw.

❑ **IMPORTANT:** After bleeding the Jack, test the Jack for proper operation prior to its actual use.

- 4.3.6. If, after bleeding, the Jack does not appear to be working properly, **DO NOT** use it until repaired by a qualified service technician.

5. OPERATION

5.1. LIFTING

- 5.1.1. Park vehicle on a flat, level, solid, surface safely away from oncoming traffic. Turn off the vehicle's engine. Place the vehicle's transmission in "PARK" (if automatic) or in its lowest gear (if manual). Set the vehicle's emergency brake. Then chock the wheels that are not being lifted.
- 5.1.2. Slowly twist the Handle counter-clockwise to lower the Jack. Once the Jack is fully lowered, twist the Handle firmly clockwise.
- 5.1.3. Carefully position the Jack's Saddle under the vehicle manufacturer's recommended lifting point. (See vehicle manufacturer's owner's manual for location of frame lifting point.)
- 5.1.4. Pump the Handle until the top of the Saddle has nearly reached the vehicle's lifting point. Position the Saddle directly under the vehicle's lifting point.
- 5.1.5. To lift the vehicle, pump the Handle. Use smooth, full strokes.
- 5.1.6. Select matching jack stands (sold separately) of appropriate capacity. Set the jack stands to the same height according to the manufacturer's instructions, making sure they lock securely into position.
- 5.1.7. Position the jack stands' saddles under the vehicle manufacturer's recommended support points.
❑ **WARNING!** Ensure that the vehicle support points are fully seated in the saddles of both jack stands. Use a matched pair of jack stands per vehicle to support one end only.
- 5.1.8. Slowly twist the Handle counter-clockwise to lower the vehicle onto the jack stands' saddles.
- 5.1.9. Once the vehicle is fully seated on the jack stands, continue slowly lowering the Jack until it is completely lowered.
- 5.1.10. Remove the Jack and store safely out of the way.

5.2. LOWERING

- 5.2.1. Carefully remove all tools, parts, etc., from under the vehicle.
- 5.2.2. Position the Jack's Saddle under the lifting point. Turn the Handle firmly clockwise and raise vehicle high enough to clear the jack stands.
- 5.2.3. Carefully remove the jack stands.
- 5.2.4. Slowly turn the Handle counter-clockwise to lower the vehicle onto the ground.
- 5.2.5. Lower the Jack completely. Store the Jack indoors out of children's reach.

6. MAINTENANCE

IMPORTANT: Only fully qualified personnel should attempt maintenance or repair.

Jacks shall be maintained and repaired in accordance with the manufacturer's instructions. Such maintenance and repair shall be carried out by qualified persons. No modifications shall be carried out which adversely affect the compliance of the jack with the standard. Check the state of the markings and that the markings remain as the initial one.

- ❑ **WARNING:** TO PREVENT SERIOUS INJURY FROM TOOL FAILURE: **DO NOT** use damaged equipment. If abnormal noise or vibration occurs, have the problem corrected before further use.
- 6.1. Before each use, inspect the general condition of the Jack, check for loose hardware, misalignment or binding of moving parts, cracked or broken parts, and any condition that may affect its safe operation.
- 6.2. Before each use, thoroughly test the Jack for proper operation prior to its actual use. If the Jack appears not to be working properly, follow Bleeding instructions in Section 4.
- 6.3. At least once every three years, change the hydraulic fluid:
 - 6.3.1. With the Jack fully lowered, remove the Fill Screw.
 - 6.3.2. Tip the Jack over to allow the old hydraulic fluid to drain out completely. Dispose of the old hydraulic fluid in accordance with local regulations.
 - 6.3.3. With the Jack upright, fill the Hydraulic Unit with high grade hydraulic fluid until the fluid is 1/4" below the top of the Fill Port.
 - 6.3.4. Turn the Handle counter-clockwise to open the Release Valve.
 - 6.3.5. Pump the Handle up and down quickly several times to purge air from the system.
 - 6.3.6. Recheck fluid level and re-fill as needed.
 - 6.3.7. Replace the Fill Screw.
- 6.4. After each use, wipe with a clean cloth. Store the Jack indoors out of children's reach.

7. TROUBLESHOOTING

- ❑ **WARNING:** TO PREVENT SERIOUS INJURY: Use caution when troubleshooting a malfunctioning jack. Stay well clear of the supported load. Completely resolve all problems before use. If the solutions presented in the Troubleshooting guide **DO NOT** solve the problem, have a qualified technician inspect and repair the jack before use.
- 7.1. After the jack is repaired: Test it carefully without a load by raising and lowering it fully, checking for proper operation, **BEFORE RETURNING THE JACK TO OPERATION.**

POSSIBLE SYMPTOMS						POTENTIAL SOLUTION (Make certain that the Jack is not supporting a load while attempting a solution.)
Jack will not lift at its weight capacity	Saddle lowers under load	Pump stroke feels spongy	Saddle will not lift all the way	Handle moves up when jack is under load	Fluid leaking from fill plug	
X	X					Check that Release Valve is fully closed. Jack may require bleeding - see instructions in section 4.
X	X			X		Valves may be blocked and may not close fully. To flush the valves: 1. Lower the Saddle and securely close the Release Valve. 2. Manually lift the saddle several inches. 3. Open the release valve by turning the Handle counter-clockwise and force the saddle down as quickly as possible.
X		X	X			Jack may be low on hydraulic fluid. Check fluid level and refill if needed - see instructions in section 4. Jack may require bleeding - see instructions in section 4.
					X	Unit may have too much hydraulic fluid inside. Check fluid level and adjust if needed - see instructions in section 4.



ENVIRONMENT PROTECTION

Recycle unwanted materials instead of disposing of them as waste. All tools, accessories and packaging should be sorted, taken to a recycling centre and disposed of in a manner which is compatible with the environment. When the product becomes completely unserviceable and requires disposal, drain any fluids (if applicable) into approved containers and dispose of the product and fluids according to local regulations.



REGISTER YOUR PURCHASE HERE

Note: It is our policy to continually improve products and as such we reserve the right to alter data, specifications and component parts without prior notice.

Important: No Liability is accepted for incorrect use of this product.

Warranty: Guarantee is 12 months from purchase date, proof of which is required for any claim.

Sealey Group, Kempson Way, Suffolk Business Park, Bury St Edmunds, Suffolk. IP32 7AR



01284 757500



sales@sealey.co.uk



www.sealey.co.uk