

Your new Jack is produced and manufactured to a high standard of dependability and will, if used according to these instructions and properly maintained, give you years of trouble free performance.



IMPORTANT: READ THESE INSTRUCTIONS CAREFULLY. NOTE THE SAFE OPERATIONAL REQUIREMENTS, WARNINGS AND CAUTIONS. USE THIS JACK CORRECTLY AND WITH CARE FOR THE PURPOSE FOR WHICH IT IS INTENDED. FAILURE TO DO SO MAY CAUSE DAMAGE AND/OR PERSONAL INJURY AND WILL INVALIDATE THE WARRANTY. RETAIN THESE INSTRUCTIONS FOR FUTURE USE.

1. SAFETY PRECAUTIONS

- ✓ Ensure the jack is in sound condition and good working order. Take action for immediate repair or replacement of damaged parts.
Use genuine parts only. The use of improper parts may be dangerous and will invalidate the warranty.
- ✓ Locate the jack in a suitable, well lit working area.
- ✓ Keep working area clean and tidy and free from unrelated materials.
- ✓ Use jack on level and solid ground, preferably concrete. *Avoid tarmac as jack may sink in.*
- ✓ Chock wheels of vehicle.
- ✓ Ensure the vehicle handbrake is engaged, engine is switched off and transmission is in gear (or "PARK" if automatic).
- ✓ Ensure minimum distance of 0.5m between vehicle and static objects such as doors, walls, etc., to allow for vehicle tilting.
- ✓ Ensure all non-essential persons keep a safe distance whilst the jack is in use.
- ✓ Ensure there are no passengers in the vehicle.
- ✓ Place jack under only those lifting points recommended by vehicle manufacturer (*see vehicle handbook*).
- ✓ Check that the lifting point is stable and centred on the jack saddle.
- ✓ Ensure the jack wheels are free to move and that there are no obstructions.
- ☐ **DANGER:** *Use the jack for lifting only, NOT for supporting the lifted load.*
- ✓ Ensure there are no persons or obstructions beneath the vehicle before lowering.
- ✓ Use suitable axle stands under the vehicle before proceeding with any task.
- ✓ Use a qualified person to lubricate and maintain the jack.
- ✓ Ensure that only **hydraulic jack oil** is used during maintenance.
- x **DO NOT** operate the jack if damaged.
- x **DO NOT** allow untrained persons to operate the jack.
- x **DO NOT** exceed the rated capacity of the jack.
- x **DO NOT** allow the vehicle to move during jacking, or use the jack to move the vehicle.
- x **DO NOT** jack vehicle if there is a risk of spillage of fuel, battery acid, or other dangerous substances.
- x **DO NOT** work under the vehicle until axle stands have been correctly positioned.
- x **DO NOT** use the jack for purposes other than that for which it is intended.
- x **DO NOT** top up hydraulic system with brake fluid. Use hydraulic jack oil only.
- x **DO NOT** adjust the safety overload valve.
- ✓ When not in use store jack, fully lowered, in a safe, dry, childproof area.



2. INTRODUCTION AND SPECIFICATION

Made primarily for the motor racing enthusiast, this jack weighs in at just 11kg. The jack utilises many weight-saving techniques such as a skeletal lift arm and single roller load wheel. Features quick lift bringing saddle to maximum height in just nine full strokes. Lifting bars are fitted either side of the anodised aluminium frame enabling fast, lightweight pick-up.

Model No:	RJA1250
Capacity	1.25 tonne
Minimum saddle height	79mm
Maximum saddle height	375mm
Maximum frame height	132mm
Length	590mm
Weight	11kg

3. ASSEMBLY

- 3.1 ASSEMBLY**
- 3.1.1 The jack comprises the following parts:
Aluminium chassis.
Two-part pumping handle.
- 3.1.2 Insert the upper handle into the lower handle.
The spring loaded locking pin will lock the two pieces together (Fig.1).
- 3.1.3 Undo the handle socket screw (A) until it no longer protrudes into the handle socket (Fig.2).
- 3.1.4 Insert the pump handle into the handle socket hole, engaging the square drive of the release valve.
- 3.1.5 Ensure that the handle is correctly inserted into the socket, then tighten the handle socket screw.

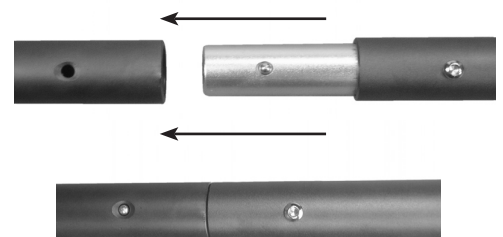

Fig.1

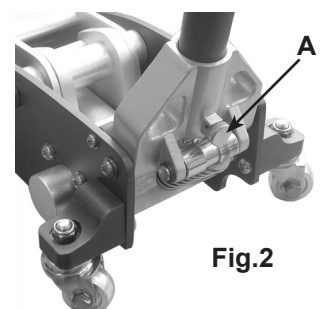

Fig.2

4. AIR SYSTEM PURGING

- 4.1 Open the release valve by turning it one full turn counterclockwise.
- 4.2 Pump the handle eight full strokes.
- 4.3 Close the release valve by turning it clockwise.

5. OPERATING INSTRUCTIONS

- ❑ **WARNING!** Before use ensure you have read, understood and apply Section 1 safety instructions.

IMPORTANT: Before use, the operator is to visually inspect the jack for cracked welds, damaged or missing parts or hydraulic leaks.

5.1 Raising a Vehicle

- 5.1.1 Ensure that the jack and the vehicle are on a hard, level surface.
 5.1.2 Always ensure that the vehicle handbrake is engaged and that the vehicle wheels are chocked.
 5.1.3 Consult the vehicle manual to determine the location of jacking points. Position the jack under a suitable lifting point.
 5.1.4 Turn the release valve clockwise, to the closed position (Fig.3). **DO NOT** over tighten.
 5.1.5 Raise the vehicle to the designed height by pumping the handle up and down.
 5.1.6 Place axle stands beneath the locations recommended by the vehicle manufacturer.
 5.1.7 Turn the release valve slowly counterclockwise to lower the vehicle on to the axle stands.

5.2 Lowering a Vehicle

- 5.2.1 Turn the release valve clockwise to the closed position.
 5.2.2 Pump the handle to raise the vehicle off the axle stands.
 5.2.3 Remove the axle stands from beneath the vehicle.
 5.2.4 Turn the release valve slowly counterclockwise to lower the vehicle to the ground.

NOTE: When not in use, **ALWAYS** leave the saddle and ram fully retracted.

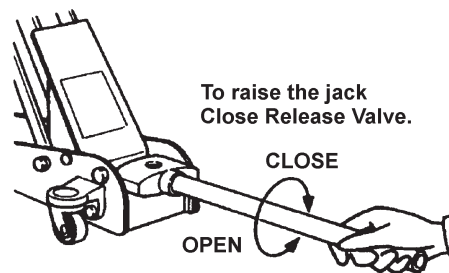

Fig.3 To lower the jack Open Release Valve

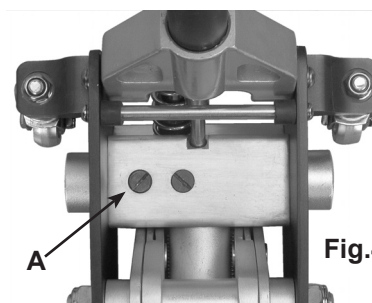

Fig.4

6. MAINTENANCE

IMPORTANT: Only fully qualified personnel should attempt maintenance or repair.

6.1 Monthly Maintenance

Lubrication is critical to jacks, since they support heavy loads. Any restriction due to dirt or rust can cause either slow jack movement, or extremely rapid jerks, causing damage to the internal components. To keep the jack well lubricated, carry out the following steps.

- 6.1.1 Lubricate the ram, the linkages and the saddle and pump mechanism with light oil.
 6.1.2 Grease the wheel bearing and axles.
 6.1.3 Keep all jack surfaces and warning labels clean.
 6.1.4 Check and maintain the ram oil level (Section 6.3).

6.2 Three Monthly Maintenance

- 6.2.1 At three monthly intervals, check the ram for any signs of rust or corrosion. Clean the ram as required and wipe with an oil cloth.

6.3 Checking the Oil Level

- 6.3.1 Fully retract the ram by turning the release valve counterclockwise.
 6.3.2 With the jack in the level position, remove the oil filler plug (Fig.4.A).
 6.3.3 The oil should be level with the bottom of the oil filler hole. If it is not top up with clean hydraulic jack oil.
 6.3.4 Replace the oil filler plug and check the jack operation.
 6.3.5 Purge air from the jacking system as required. Refer to Section 4.

NOTE: Always store the jack in the fully lowered position. This will protect critical areas from excessive corrosion.

IMPORTANT: NO RESPONSIBILITY IS ACCEPTED FOR INCORRECT USE OF THIS PRODUCT.

Hydraulic products are only repaired by local service agents. We have service/repair agents in all parts of the UK.

DO NOT RETURN JACKS TO US.

Please telephone us on 01284 757500 to obtain the address and phone number of your local agent. If jack is under guarantee you can also contact your local dealer.

De-commissioning the Jack

Should the jack become completely unserviceable and require disposal, draw off the oil into an approved container and dispose of the jack and the oil according to local regulations.

7. TROUBLESHOOTING

PROBLEM	CAUSE	REMEDY
Jack will not lift to full height	Oil level low	Check / top up oil level.
Jack will not hold the load	Release valve not closing Hydraulic jack oil is contaminated Pump valves not sealing	Call for customer service
Lift arm will not lower	Cylinder ram binding Parts worn Internal component damage Broken or unhooked return spring Lift arm linkage either bent or binding	Call for customer service
Jack feels spongy when lifting	System requires purging	Refer to air purge procedure at Section 3

NOTE: It is our policy to continually improve products and as such we reserve the right to alter data, specifications and component parts without prior notice.

IMPORTANT: No liability is accepted for incorrect use of this product.

WARRANTY: Guarantee is 12 months from purchase date, proof of which will be required for any claim.

INFORMATION: For a copy of our latest catalogue and promotions call us on 01284 757525 and leave your full name and address, including postcode.



Sole UK Distributor, Sealey Group,
 Kempson Way, Suffolk Business Park,
 Bury St. Edmunds, Suffolk,
 IP32 7AR

01284 757500

www.sealey.co.uk

01284 703534

sales@sealey.co.uk