



# INSTRUCTIONS FOR: BUMPER RACK DOUBLE-SIDED 4-LEVEL

Model No: RE55.V5

Thank you for purchasing a Sealey product. Manufactured to a high standard this product will, if used according to these instructions and properly maintained, give you years of trouble free performance.

**IMPORTANT: PLEASE READ THESE INSTRUCTIONS CAREFULLY. NOTE THE SAFE OPERATIONAL REQUIREMENTS, WARNINGS AND CAUTIONS. USE THE PRODUCT CORRECTLY AND WITH CARE FOR THE PURPOSE FOR WHICH IT IS INTENDED. FAILURE TO DO SO MAY CAUSE DAMAGE AND/OR PERSONAL INJURY AND WILL INVALIDATE THE WARRANTY. PLEASE KEEP INSTRUCTIONS SAFE FOR FUTURE USE.**

## 1. SAFETY INSTRUCTIONS

- ✓ Familiarise yourself with the application, limitations and hazards of the rack.
- ✓ Maintain the rack in good condition (use authorised replacement parts).
- ✓ Keep the rack clean for best and safest performance.
- ✓ Locate the rack in a suitable work area.
- ❑ **WARNING!** Use the rack on level and solid ground, preferably concrete.
- ✗ **DO NOT** overload the rack.
- ✗ **DO NOT** climb on the rack.
- ✗ **DO NOT** use the rack for any purpose other than for which it is designed.
- ✗ **DO NOT** use the rack if any parts are damaged or missing as this may cause failure and/or personal injury.
- ✓ Keep the work area clean, uncluttered and ensure that there is adequate lighting.
- ✓ Keep children and unauthorised persons away from the work area.
- ❑ **WARNING: The warnings, cautions and instructions discussed in this manual cannot cover all possible conditions and situations that may occur. It must be understood that common sense and caution are factors which cannot be built into this product, but must be applied by the operator.**

## 2. INTRODUCTION

Double-sided rack for safe and tidy workshop storage of painted bumpers. Prevents inadvertent damage to paint finish during storage. Four pairs of height adjustable support arms for maximum capacity and flexibility. Fitted with four castors, two with brake, for maximum manoeuvrability and safe positioning.

## 3. ASSEMBLY INSTRUCTIONS

Refer to diagram overleaf.

- 3.1. Lay T plate (9), (smooth side down) under each end of base tube (1).
- 3.2. Lay end base tubes (6) perpendicular to base tube (1).
- 3.3. Place vertical tube (8) onto the top of each of the ends of the base tube (1).
- 3.4. Use four screws (7), washers (21) nuts (20) to bolt the three tubes, of each end, together.
- 3.5. Put two long cross tubes (12) onto each lower vertical tube (8) and secure with knob (11).
- 3.6. Place the handle tube (10) over one of the lower vertical tubes (8) and secure with knob (11).
- 3.7. Insert the upper vertical tubes (14) into the lower vertical tubes (8).
- 3.8. Insert screw (19) through the hole in each upright tube (8 & 14) and fix circle tube (17) between them.
- 3.9. Put two short cross tubes (15) onto each of the upper vertical tubes (14) and secure with knobs (11).
- 3.10. Place circle tube (17) between the upper vertical tubes and use screw (19) to fix circle tube between them.
- 3.11. Fix on castors (5) ensuring that braked ones go onto one end.
- 3.12. Fit long foam (13) and short foam (16) covers onto their respective cross tubes.
- 3.13. Fit end plugs (18) into the end of each cross tube.

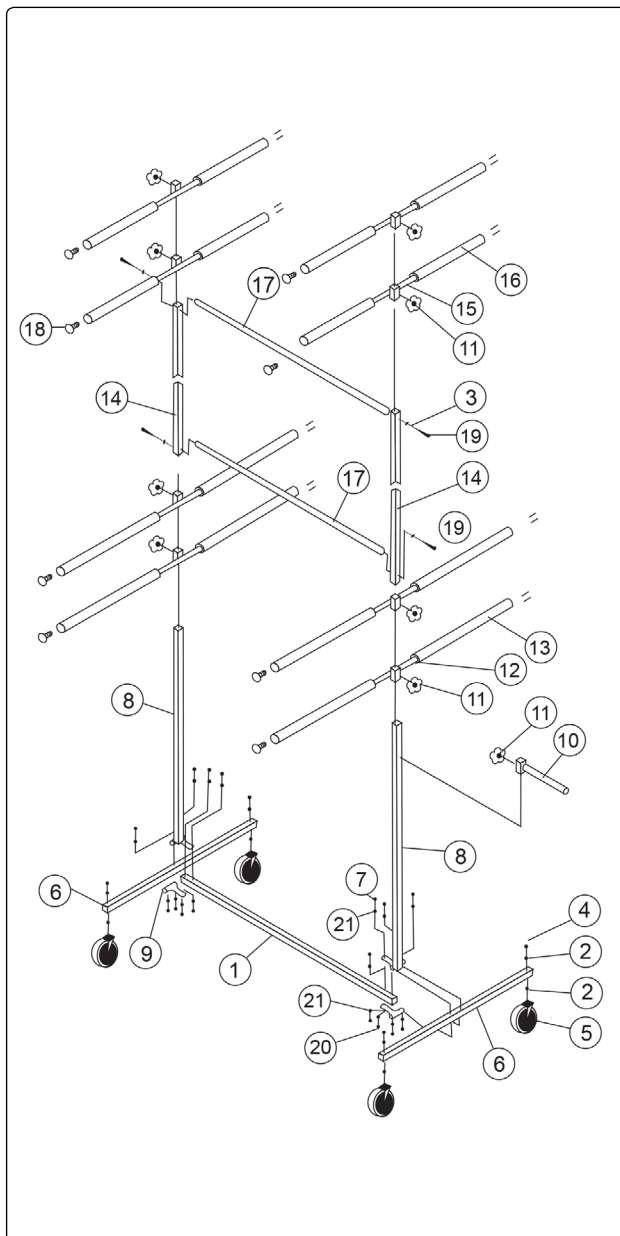

### Environmental Protection.

Recycle unwanted materials instead of disposing of them as waste. All tools, accessories and packaging should be sorted, taken to a recycle centre and disposed of in a manner which is compatible with the environment.

**NOTE:** It is our policy to continually improve products and as such we reserve the right to alter data, specifications and component parts without prior notice.

**IMPORTANT:** No liability is accepted for incorrect use of this product.

**WARRANTY:** Guarantee is 12 months from purchase date, proof of which will be required for any claim.

**INFORMATION:** For a copy of our latest catalogue and promotions call us on 01284 757525 and leave your full name and address, including postcode.



Sole UK Distributor, Sealey Group,  
Kempson Way, Suffolk Business Park,  
Bury St. Edmunds, Suffolk,  
IP37 2AR



01284 757500



www.sealey.co.uk



01284 703534



sales@sealey.co.uk