



INSTRUCTIONS FOR
COIL SPRING COMPRESSOR
MODEL NO: **RE300**

Thank you for purchasing a Sealey product. Manufactured to a high standard, this product will, if used according to these instructions, and properly maintained, give you years of trouble free performance.

IMPORTANT: PLEASE READ THESE INSTRUCTIONS CAREFULLY. NOTE THE SAFE OPERATIONAL REQUIREMENTS, WARNINGS & CAUTIONS. USE THE PRODUCT CORRECTLY AND WITH CARE FOR THE PURPOSE FOR WHICH IT IS INTENDED. FAILURE TO DO SO MAY CAUSE DAMAGE AND/OR PERSONAL INJURY AND WILL INVALIDATE THE WARRANTY. KEEP THESE INSTRUCTIONS SAFE FOR FUTURE USE.



Refer to instructions



Wear eye protection



Wear protective gloves



Wear safety footwear



Wear protective clothing

1. SAFETY

- 1.1. **GENERAL SAFETY.**
 - WARNING!** Ensure Health & Safety, local authority, and general workshop practice regulations are adhered to when using this equipment.
 - WARNING!** Wear approved safety hand and eye protection (standard spectacles are not adequate).
 - WARNING! TRAPPING DANGER** – Keep hands and fingers away from the spring and compressing jaws in use.
 - Keep the work area clean, uncluttered and ensure there is adequate lighting.
 - Maintain correct balance and footing. Ensure the floor is not slippery and wear non-slip shoes.
 - Remove ill-fitting clothes. Remove ties, watches, rings, other loose jewellery. Contain and/or tie back long hair.
 - Wear appropriate protective clothing.
 - Familiarise yourself with the applications, limitations and potential hazards of the spring compressor.
 - DO NOT** force the spring compressor to achieve a task it was not designed to perform.
 - DO NOT** allow untrained persons to use the spring compressor.
- 1.2. **PRE-OPERATIONAL SAFETY.**
 - Apply grease to the front and rear faces of the main upright to assist the smooth action of the compressor.
 - DO NOT** operate compressor if parts are damaged or missing as this may cause failure and/or personal injury.
 - Before commencing compression, make visual inspection of machine to ensure pins are securely positioned and that there is no sign of wear or fatigue – if found, do not use and refer to your local Sealey dealer for advice and replacement parts.
 - Ensure jaw locating pins are properly positioned and safety clips are attached correctly.
 - Before commencing compression of spring, ensure coils of the spring are seated securely in the jaws of the compressor and cannot slide out during compression.
 - ALWAYS** ensure that the safety guard locks in place, and also use the chain to secure the spring safely.
- 1.3. **OPERATIONAL SAFETY.**
 - When applying compression to the spring, always stand to one side of the compressor.
 - ▲ DANGER!** Stop compressing the spring before the coils touch.
 - Before attempting to remove top cap nut, always use a tool or similar to test if the compression has been relieved, Do not use your hands / fingers.
 - We recommend the use of purpose made strut tools to remove the top-nut from the shock piston.
 - Once compressed, and the strut removed, we recommend releasing the tension on the spring. **Do not** leave the spring under compression in the machine unattended and do not leave in compression for prolonged periods, i.e. overnight.
 - Before releasing the compression ensure that the top strut-nut is securely tightened to the manufacturer's tolerance.
 - Release the compression slowly keeping your hands and fingers away from the spring assembly.
 - Be sure that the tension on the spring is fully controlled by the strut assembly before removing it from the jaws of the compressor.
- 1.4. **POST OPERATIONAL SAFETY.**
 - When not in use, clean and store the spring compressor in a safe, dry, childproof location.
 - Maintain the spring compressor in good condition. Replace or repair damaged parts. Use genuine parts only.
 - Unauthorised parts may be dangerous and will invalidate the warranty.

2. INTRODUCTION

Fast and safe compression of road springs. 1000kg Air operated unit with safety locking guard. Supplied with two interchangeable plastic coated lower yokes and a suspension strut clamp. Fits a wide range of spring configurations and diameters. Also features a strut locating platform for easy movement of the suspension strut to avoid unnecessary lifting.

3. SPECIFICATION

Model no.	RE300
Maximum Load.....	1000kg
Upper Yoke travel.....	420mm
Spring Diameter	102-165mm
Actuation	foot Pedal
Maximum Air pressure	116psi(8bar)

4. ASSEMBLY

Unpack the spring compressor carefully, it will be necessary for two people to do this.

4.1. Assemble the spring compressor as follows:

4.1.1. Lay out all of the parts ready for assembly.

4.1.2. Fit the two feet to the bottom of the frame with the wheels facing rearwards. Use four allen bolts, flat washers, spring washers and domed nuts, to secure in place.

NOTE: the one longer bolt is fitted in position as shown in fig.1.

4.1.3. Using two people, stand the unit onto it's feet, taking care when the wheels come into contact with the floor as the unit's weight might become unstable.

4.1.4. Fix the guard lock to the front of the unit using four cross headed bolts, see fig.4 for positioning.

4.1.5. Fit the guard by dropping it onto the bottom pivot and then fitting the large pin and spring into the top pivot holes and fitting a nyloc nut (fig.2). Some pressure will be needed to push down on the pin to allow the nut to be fitted.

4.1.6. Fit the chain to the left hand side using nut and bolt to fix in place. Remove the clip from the end of the chain and clip it onto the hook on the other side of the compressor, the chain can then be fixed to the clip at the appropriate link as required (fig.3).

4.1.7. Fit the locating platform by threading it onto the long metal rod and securing it by fitting and tightening the knob. The top of the rod fits through the hole in the frame and is held in place using a domed nut and washer. The bottom of the rod is secured by attaching the metal arm to it and securing with a nut. Then undo the domed nut previously fitted (fig.1), and fit the metal arm over the bolt and refit the domed nut. Tighten all nuts in turn ensuring that the metal rod hangs vertically from the frame and also squarely to the metal arm (see fig.5).

4.1.8. Fit the handle to the top of the unit using two domed nuts, spring washers and washers to secure in place.

4.1.9. There are pre-drilled holes in the feet if the unit needs to be bolted to the floor permanently.

4.1.10. Hang two of the brackets/attachments to the sides of the frame and locate the third bracket onto the compressor using the locking pin to hold it in position (fig.7).

4.1.11. Position the unit in a suitable location near an air line feed.

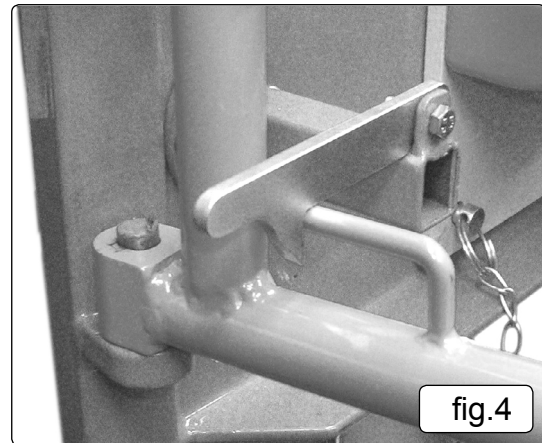
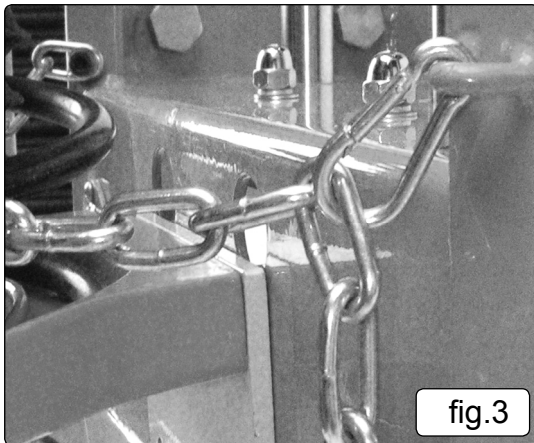
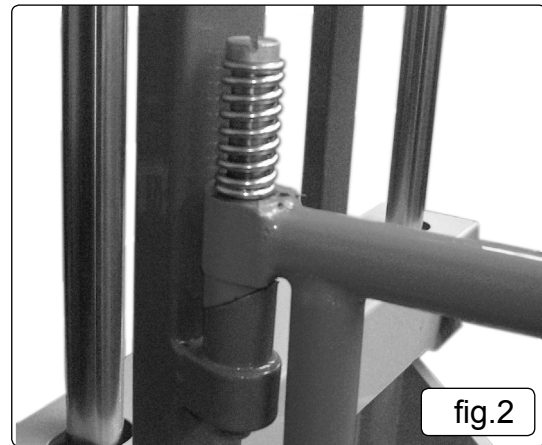
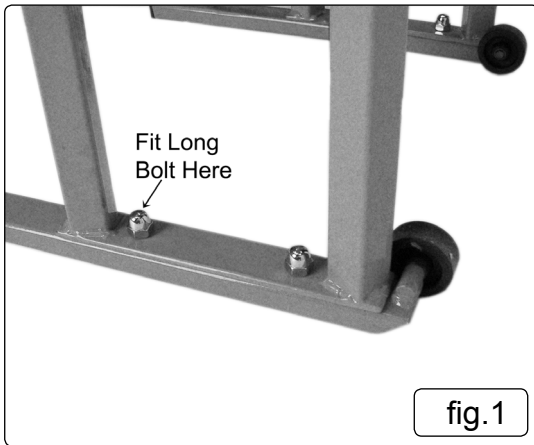

4.2. The recommended air hook-up procedure is shown in fig.6.

4.2.1. Ensure foot control lever is in the 'Off' position before connecting to the air supply.

4.2.2. A maximum air pressure of 116psi (8bar) is required to operate at full capacity.

- ❑ **WARNING!** Ensure the air supply is clean and does not exceed 116psi (8bar) whilst operating the compressor. Too high an air pressure and unclean air will shorten the product life due to excessive wear, and may be dangerous causing damage and/or personal injury.

4.2.3. Drain the air tank daily. Water in the air line will damage the ram.

4.2.4. Clean compressor air inlet filter weekly.

4.2.5. Line pressure should be increased to compensate for unusually long air hoses (over 8 metres).

4.2.6. Keep hose away from heat, oil and sharp edges. Check hose for wear, and make certain that all connections are secure.



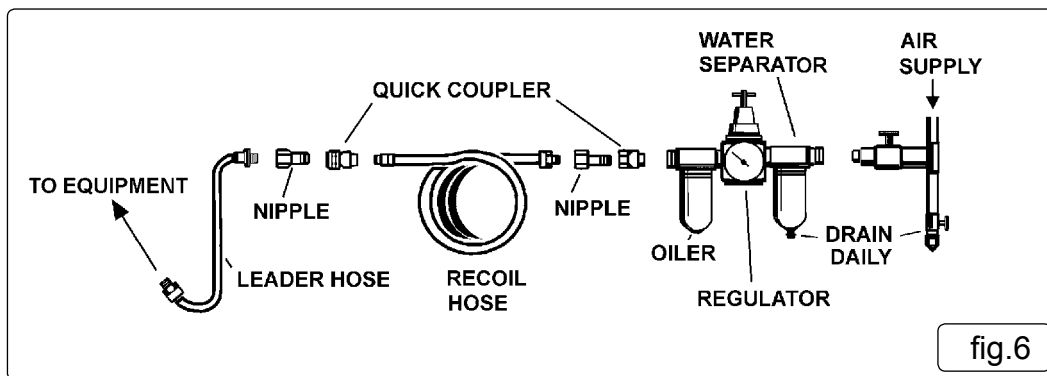

5. OPERATION

- 5.1. **Compressing a strut spring.**
Note! Before removing the strut from the vehicle it is recommended that the upper strut locking plate nut is loosened a quarter turn. **DO NOT** loosen more than a quarter turn.
- 5.1.1. With the strut and spring removed from the vehicle, select the most suitably sized bracket or the strut clamp according to the size of the spring and fit it onto the compressor using the locking pin to hold it in position (fig.7).
- 5.1.2. Position the lowest coil of the spring in the lower bracket. and rotate the strut and spring, so that the coil is held as low as possible (fig.8)
- 5.1.3. Swing the small upper arms into position and locate the upper brackets on the uppermost available coil (fig.9). Ensure that the coil is placed inside the recesses of the brackets to ensure that the coil will not break free under compression.
- 5.1.4. Having correctly positioned the spring on the lower and upper brackets, tighten all the locking knobs (fig.10).
- 5.1.5. Relocate the locating platform if required, so that it is just underneath the bottom of the strut and secure it in place.
- 5.1.6. Use the chain to secure the spring by pulling it across the spring and hooking it onto the clip. Shut the safety guard ensuring that it locks in place.
- 5.1.7. Check to make sure that the spring is safely secured and then start to compress the spring coils. Gradually press the correct pedal on the foot control to start the compression, stopping to check the spring is still securely held.
- WARNING!** Keep hands away from the spring whilst compressing.
 - DANGER!** Stop compressing the spring before the coil windings touch.
 - WARNING!** If the spring/strut is not located correctly in the jaws, it is possible that the strut/top retaining cap could be subject to sideways forces. Watch closely as the spring reaches it's final phase of compression and ensure the top cap assembly rotates freely before attempting to remove it.
- 5.1.8. When the strut is loose within the spring, unscrew the strut locking plate nut and remove the locking plate from the top of the strut, gradually discharge the pressure on the spring by operating the foot control pedal. When all the pressure has been released, taking care to support the strut and spring assembly when it becomes loose, move the locating platform and withdraw the strut and release the spring from the retaining brackets if required.

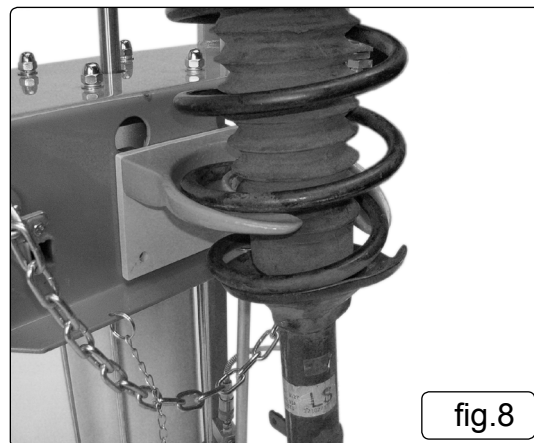
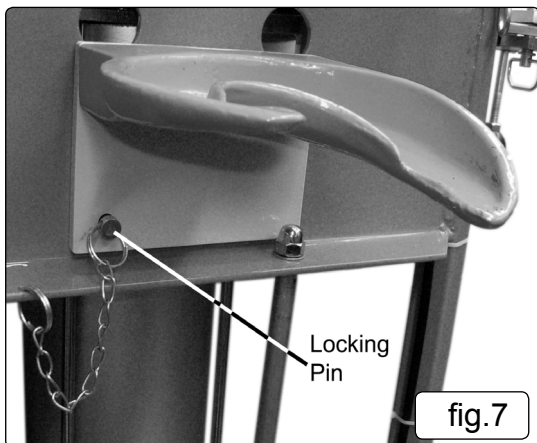

- 5.2. **Fitting a strut spring.**
- 5.2.1. Offer the new strut spring up to the compressor's brackets and fit it in the same position as that of the old spring. Position the lowest coil of the spring in the lower bracket. and rotate the spring, so that the coil is held as low as possible. Swing the small upper arms into position and locate the upper brackets on the uppermost available coil. Ensure that the coil is placed inside the recesses of the brackets to ensure that the coil will not break free under compression. Tighten all the locking knobs (fig.10).
Note: There must be coils free at either end to allow them to seat on the strut plates, without the strut and compressor brackets interfering.
- 5.2.2. Insert the strut up inside the spring, and move the locating platform just underneath the bottom of the strut to support it and secure it in place by turning the knob.
- 5.2.3. Use the chain to secure the spring by pulling it across and hooking it onto the clip. Shut the safety guard, ensuring that it locks in place.
- 5.2.3. Compress the spring using the correct pedal on the foot control unit, ensuring that the spring is securely held in place within the bracket recesses at all times.
- WARNING!** Keep hands away from spring.
- 5.2.4. **DANGER!** Stop compressing the spring before the coil windings touch
- 5.2.5. When the spring is compressed sufficiently, fit the top locking plate to the strut, and using a new nut, secure it in position.
- 5.2.6. Decompress the spring carefully and slowly, using the pedal on the foot control unit, ensuring the spring locates properly.
- 5.2.7. Remove complete strut carefully from the spring compressor.
- 5.2.8. When re-fitting the strut to the vehicle, the locking plate nut will need to be fully tightened using a torque wrench, to a setting in accordance with the vehicle manufacturer's specification.

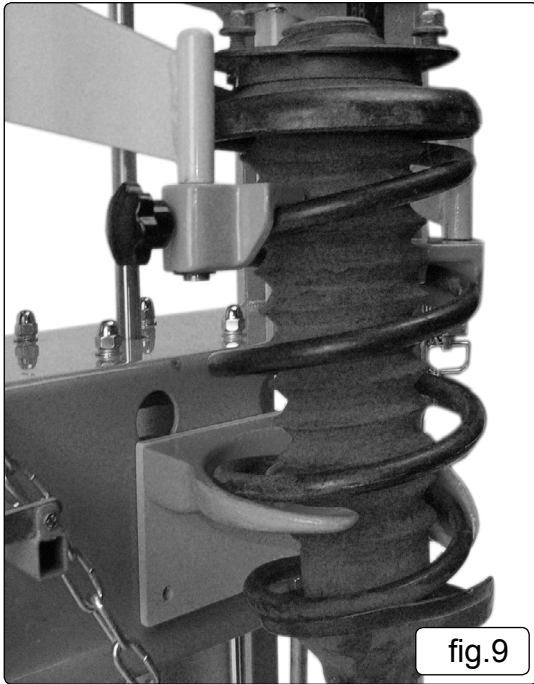

fig.9

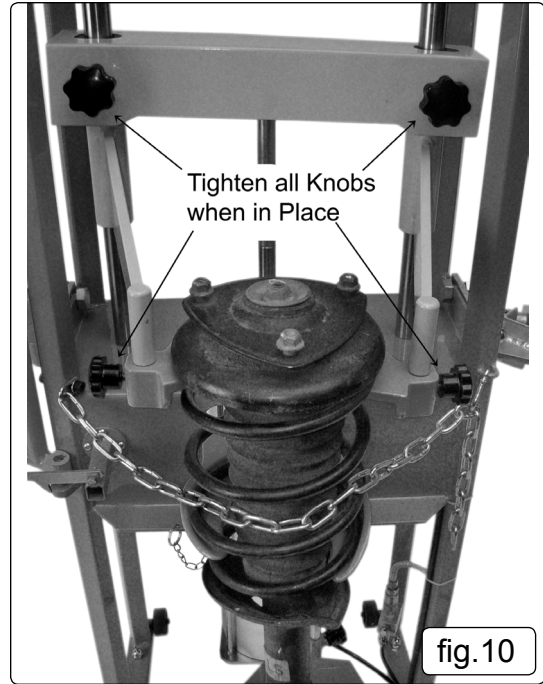

fig.10

6. MAINTENANCE

- 6.1. Before each use, check the Spring Compressor to ensure it is not damaged or worn. If in any doubt **DO NOT** use the Spring Compressor. Remove it from service immediately and contact your local Sealey dealer for advice and/or repairs.
- 6.2. Periodically clean the sliding columns and wipe over using a little transmission oil.
- 6.3. Any other maintenance required should be carried out by an authorised service agent.
- 6.4. If the Spring Compressor is not being used for a considerable length of time, disconnect the air supply and discharge any air in the cylinder by depressing the foot control lever. Drop a little Sealey air tool oil into the air inlet and cover to prevent the ingress of any foreign matter.

Parts support is available for this product. To obtain a parts listing and/or diagram, please log on to www.sealey.co.uk, email sales@sealey.co.uk or telephone 01284 757500.



Environmental Protection

Recycle unwanted materials instead of disposing of them as waste. All tools, accessories and packaging should be sorted, taken to a recycling centre and disposed of in a manner which is compatible with the environment. When the product becomes completely unserviceable and requires disposal, drain off any fluids (if applicable) into approved containers and dispose of the product and the fluids according to local regulations.

NOTE: It is our policy to continually improve products and as such we reserve the right to alter data, specifications and component parts without prior notice.

IMPORTANT: No liability is accepted for incorrect use of this product.

WARRANTY: Guarantee is 12 months from purchase date, proof of which will be required for any claim.



Sole UK Distributor, Sealey Group.
Kempson Way, Suffolk Business Park,
Bury St. Edmunds, Suffolk.
IP32 7AR



01284 757500



01284 703534



www.sealey.co.uk



sales@sealey.co.uk