

# SEALEY

## SEALEY, 500A PROFESSIONAL GAS/GASLESS MIG/MMA/TIG INVERTER WELDER WITH PORTABLE WIRE FEEDER 415V 3PH

MODEL NO: **POWERMIG500i POWERMIG500Wi**

Thank you for purchasing a Sealey product. Manufactured to a high standard, this product will, if used according to these instructions, and properly maintained, give you years of trouble free performance.

**IMPORTANT:** PLEASE READ THESE INSTRUCTIONS CAREFULLY. NOTE THE SAFE OPERATIONAL REQUIREMENTS, WARNINGS & CAUTIONS. USE THE PRODUCT CORRECTLY AND WITH CARE FOR THE PURPOSE FOR WHICH IT IS INTENDED. FAILURE TO DO SO MAY CAUSE DAMAGE AND/OR PERSONAL INJURY AND WILL INVALIDATE THE WARRANTY. KEEP THESE INSTRUCTIONS SAFE FOR FUTURE USE.



Refer to instructions



Wear a welding mask



Wear protective gloves



Wear safety footwear



Electrical shock hazard



Hot surfaces



Do not use in the vicinity of a pacemaker



Welding sparks can cause explosions or fire.



Wear protective clothing



Arc rays can burn eyes and injure skin.



Breathing welding fumes can be hazardous to your health.

Do not use in rain



### 1. SAFETY

#### 1.1. ELECTRICAL SAFETY

- WARNING!** It is the user's responsibility to check the following:  
Check all electrical equipment and appliances to ensure that they are safe before using.  
Inspect power supply leads, plugs and all electrical connections for wear and damage.  
Ensure that the insulation on all cables and on the appliance is safe before connecting it to the power supply.
- DO NOT** use worn or damaged cables, plugs or connectors.
- Ensure that any faulty item is repaired or is replaced immediately by a qualified electrician.
- If the cable or plug is damaged during use, switch off the electricity supply and remove from use.  
**Ensure that repairs are carried out by a qualified electrician.**
- Sealey recommend that an RCD (Residual Current Device) is used with all electrical products.  
**Important:** Ensure that the voltage rating on the appliance suits the power supply to be used and that the plug is fitted with the correct fuse.
- DO NOT** pull or carry the appliance by the power cable.
- DO NOT** pull the plug from the socket by the cable.

#### 1.2. GENERAL SAFETY

- Welding power sources are not suitable for use in rain or snow
- The output is rated at an ambient temperature of 20°C and the welding time may be reduced at higher temperatures
- Risk of electric shock: Electric shock from welding electrode can kill.
- DO NOT** weld in the rain or snow.
- DO NOT** operate on a slope or uneven ground.
- Wear dry insulating gloves.
- DO NOT** touch electrode with bare hands.
- DO NOT** wear wet or damaged gloves.
- Protect yourself from electric shock by insulating yourself from workpiece.
- DO NOT** open the equipment enclosure.
- WARNING!** Welding fumes: Breathing welding fumes can be hazardous to your health. Keep your head out of the fumes.
- Use equipment in an open area.
- Use ventilating fan to remove fumes.
- WARNING!** Risk induced by welding sparks: Welding sparks can cause explosion or fire. Keep flammables away from welding.
- DO NOT** weld near flammables. Welding sparks can cause fires. Have a fire extinguisher nearby and a watchperson ready to use it.
- DO NOT** weld on drums or any closed containers.
- WARNING!** Risk induced by the arc: Arc rays can burn eyes and injure skin.
- Use welding helmet with correct shade of filter. Wear complete body protection.
- WARNING!** Risk induced by electromagnetic fields: Welding current produces electromagnetic field.
- DO NOT** use with medical implants. Never coil welding cables around your body. Route the welding cables together.
- The operator should be properly trained to use the welder safely and should be informed about the risks relating to MIG and ARC welding procedures, the associated protection measures and emergency procedures.
- DANGER!** Unplug the welder from the mains power supply before performing maintenance or service.
- Keep the welder and cables in good working order and condition. (Take immediate action to repair or replace damaged parts).
- Use genuine parts and accessories only. (Non recommended parts may be dangerous and will invalidate the warranty).
- Use an air hose to regularly blow out any dirt from the liner and keep the welder clean for best and safest performance.
- Check and spray the gas cup and contact tip regularly with anti-spatter spray available from your Sealey stockist.

- ✓ Locate welder in adequate working area for its function. Ensure area has adequate ventilation as welding fumes are harmful.
- ✓ Keep working area clean, tidy and free from unrelated materials. Also ensure the working area has adequate lighting, and that a fire extinguisher is at hand.
- **WARNING!** Always use a welding helmet or mask to protect your eyes.
- ✓ Use special fire resistant protective clothing and **DO NOT** allow the skin to be exposed to the ultraviolet and infrared rays produced by the arc. Other people in the vicinity of the arc should be protected by shields of non reflecting welding curtains.
- ✓ The operator should be adequately insulated from the electrode, the work piece and any accessible earthed metal parts in the vicinity by the wearing of safety shoes and welding gauntlets plus the aforementioned safety clothing.
- ✓ Where necessary the operator should work on insulating mats or on an insulated safety platform in elevated positions.
- ✓ Remove ill fitting clothing, remove ties, watches, rings, and other loose jewellery, and contain long hair.
- ✓ Ensure the workpiece is correctly secured before operating the welder.
- ✓ Avoid unintentional contact with workpiece. Accidental or uncontrolled use of the torch may be dangerous and will wear the nozzle.
- ✓ Keep non essential persons away from the working area. Any persons working within the area must use protective head shield and gloves.
- ✓ Operators must receive adequate training before using the welder. The welder must only be operated under supervision.
- ✓ Stand correctly keeping a good footing and balance, and ensure the floor is not slippery, and wear non-slip shoes.
- ✓ Turn voltage switch to "0" or off when not in use.
- ✗ **DO NOT** operate the welder if it or its cables are damaged and **DO NOT** attempt to fit any non genuine torches, components, or parts to the welder unit.
- ✗ **DO NOT** get welder wet or use in damp or wet locations or areas where there is condensation.
- ▲ **DANGER! DO NOT** weld near inflammable materials, solids, liquids, or gases, and **DO NOT** weld containers or pipes which have held flammable materials or gases, liquids or solids. Avoid operating on materials cleaned with chlorinated solvents or near such solvents.
- ✗ **DO NOT** touch any live metal parts of the torch or electrode while the machine is switched on.
- ✗ **DO NOT** weld on any containers which are under pressure.
- ✗ **DO NOT** pull the welder by the mains cable or by the umbilical connection cable.
- ✗ **DO NOT** pull the wire feed unit by the umbilical connection cable or by the torch cable, and **DO NOT** bend or strain cables, protect from sharp or abrasive items, and **DO NOT** stand on cables or leads. Protect from heat. Lengths of slack must be gathered & neatly coiled.
- ✗ **DO NOT** place cables where they endanger others.
- ✗ **DO NOT** touch the torch or workpiece immediately after welding as they will be very hot. Allow to cool.
- ✗ **DO NOT** operate welder while under the influence of drugs, alcohol or intoxicating medication, or if fatigued.
- ✓ When not in use store the welder in a safe, dry, childproof area.
- ✗ **DO NOT** weld in the rain.
- ✓ Provide adequate ventilation or facilities for the removal for of welding fumes from near the arc. The risk should be assessed by a Health and Safety professional in relation to the exposure limits for the welding fumes, which will depend on their composition, concentration and the exposure time
- **WARNING!** Electromagnetic interference: The electromagnetic fields generated by the welding process may interfere with the operation of electrical and electronic equipment. Users of vital electronic and electrical devices such as pacemakers and respirators are advised not to remain in the vicinity of an operating welding machine. If in doubt seek medical advice before entering a welding area. Users of such devices should not operate the welding machine. This welder complies with the requirements of the technical standard for the use of this type of product, only and exclusively in industrial environments and for professional purposes. It is not guaranteed to meet electronic compatibility requirements in the home.
- **WARNING!** Gas safety: Store gas cylinders in a vertical position only and ensure the storage area is correctly secured.
- ✗ **DO NOT** store gas cylinders in areas where temperature exceeds 50°C. **DO NOT** use direct heat on a cylinder. Keep gas cylinders cool.
- ✗ **DO NOT** attempt to repair or modify any part of a gas cylinder or valve, and **DO NOT** puncture or damage a cylinder.
- ✗ **DO NOT** obscure or remove any official labels from a cylinder. Always check the gas identity before use. Avoid getting gas cylinders oily or greasy.
- ✗ **DO NOT** try to lift or handle cylinder by its cap, guard or valve. Always keep caps and guards in place and close valve when not in use.
- ✓ The gas cylinder is heavy, use mechanical lifting equipment. Ensure the cylinder is correctly situated on the welder base stand and secured with chain.
- ✓ Risk assessment: Where welding is unavoidable in awkward situations such as in confined spaces, in environments with increased risk of electric shock, and in the presence of inflammable or explosive materials, a risk assessment must be carried out by an experienced and qualified expert professional in consultation with providers of emergency services to ensure that operations are carried out in the safest possible way.
- **WARNING!** Risk induced by electromagnetic fields: Welding current produces a electromagnetic field. **DO NOT** use with medical implants.. Never coil welding cables around your body. Route the welding cables together.
- **WARNING! DO NOT** place the welding power source on a tilted plane as this may lead to the unit toppling over.
- ✗ **DO NOT** use welding power source for pipe thawing

## 2. INTRODUCTION

Multi process IGBT inverter Gas/Gasless MIG/TIG/MMA welder suitable for professional fabricators and workshops, as well as mechanics and technicians. Fitted with a portable wire feeder allowing access into high or tight spaces that otherwise would not be possible. Maximum output of 500A making it ideal for welding a large variety of metals including Steel, Stainless Steel up to 20mm. 2T/4T torch trigger function allowing greater precision during longer welds. Features short circuit, over-heating and over-current protection. Supplied with 2m power cable, 2m earth clamp, 3m Euro Mig torch and 2m Electrode holder. Wire capacity of 5-15kg with a diameter of 0.6mm to 1.6mm. Electrode capacity from 1.6mm to 5mm. Duty Cycle: MIG 60% @ 500A, MMA 60% @ 500A, TIG 40% @ 500A. POWERMIG500Wi is also supplied with a water cooler to prolong duty cycle and efficiency.

### 3. CONTENTS

	Description	Part No.
1	Earth clamp set 2m (not shown)	POWERMIG500Wi-99
1	Gas hose 3m (not shown)	POWERMIG500Wi-100
1	Electrode holder set 2m (not shown)	POWERMIG500Wi-101
1	Power cable 2m (not shown)	POWERMIG500Wi-102
1	3 Mig Torch 3m (not shown)	POWERMIG500Wi-103
1	Signal connection cable (not shown)	POWERMIG500Wi-104
1	Power connection cable (not shown)	POWERMIG500Wi-105
1	Euro mig Torch 3m (not shown)	POWERMIG500i-85

### 4. SPECIFICATION

Model No	POWERMIG500i
Welding Current	50-500A
Wire Capacity	5-15kg
Electrode Capacity	1.6-5mm
Duty Cycle MIG	60% @500A 100% @ 388A
Duty Cycle MMA	60% @ 500A 100% @ 388A
Duty Cycle TIG	60% @ 500A 100% @ 388A
Gas Type	CO2, Argon, CO2/Argon Mix
Mig Torch (inc)	3m Euro Non-Live Binzel
Supply	415V -3ph

Power Supply Cable Length	2m
Weight POWERMIG500i	42.5kg
Weight POWERMIG500Wi	55.7kg
EMC Classification	Class A.
IP Rating	IP21S



### 5. OPERATION

Mode	Material	Gas
MMA	Steel	Not required
TIG	DC TIG: Steel, Stainless steel	Pure argon
	AC TIG: Aluminum	
MIG/MAG	Steel	20% CO2 +80% argon or Pure CO2 25% CO2 +75% argon 10% CO2 +90% argon
	Stainless steel	2% CO2+98% argon or tri-mix gas 2% O2+98% argon
	Aluminium	Pure argon
FLUX CORED	Steel	Not required

Feed Wheel Type	Welded materials
U-shaped wheel	Aluminium only
Knurled wheel	Flux cored welding wire
V-shaped wheel	Steel, Stainless steel

Mode	Tools	Workpiece polarity	Torch polarity
MMA	Grounding clamp Welding torch	Negative	Positive
TIG	Grounding clamp TIG Welding torch Argon cylinder	Positive	Negative
MIG/MAG	Grounding clamp MIG Welding torch Cylinder	Negative	Positive
FLUX CORED	Grounding clamp FLUX CORED Welding torch	Positive	Negative
	Grounding clamp FLUX CORED Welding torch Cylinder	Negative	Positive

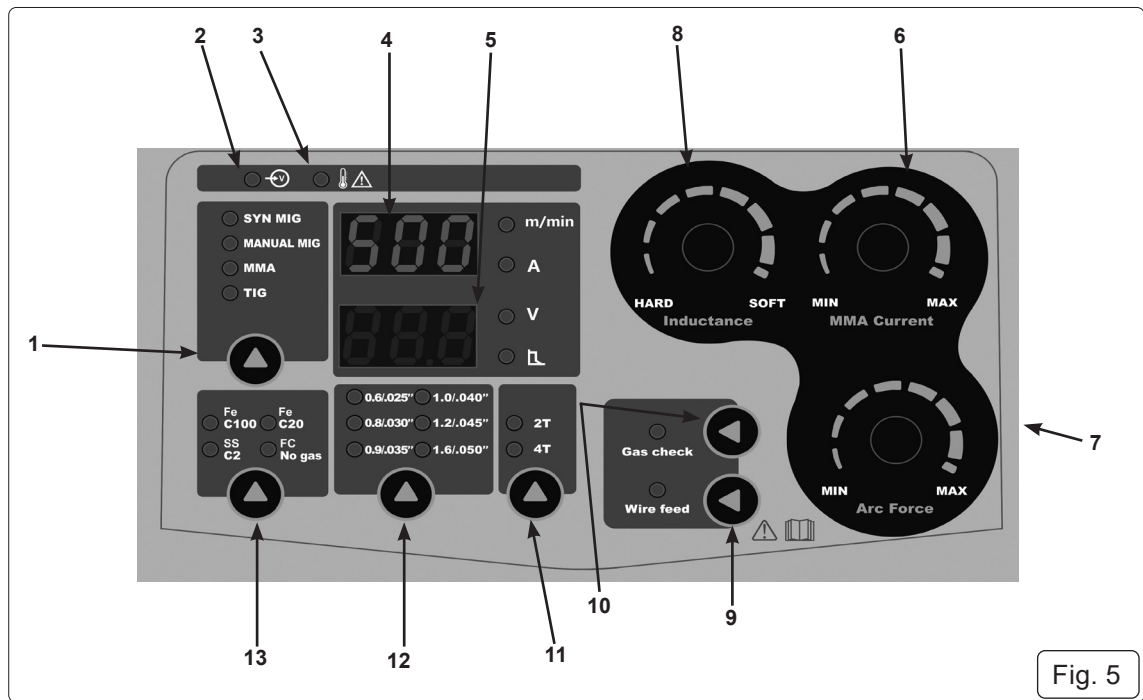
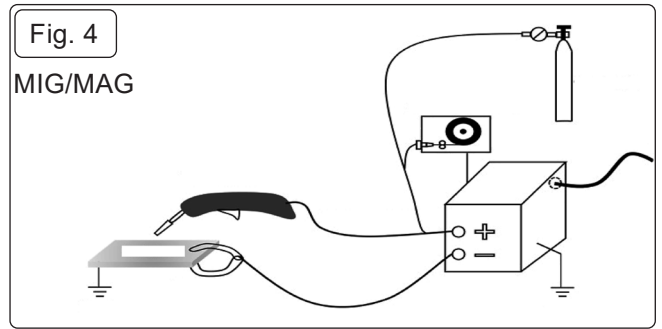
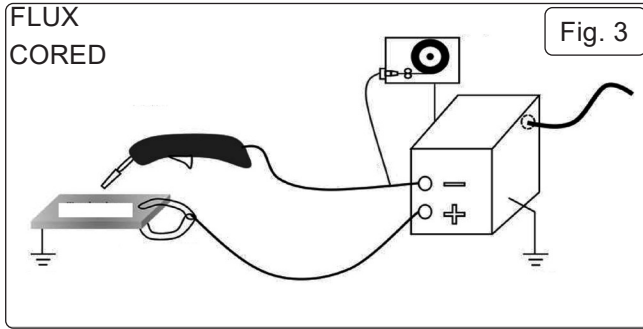
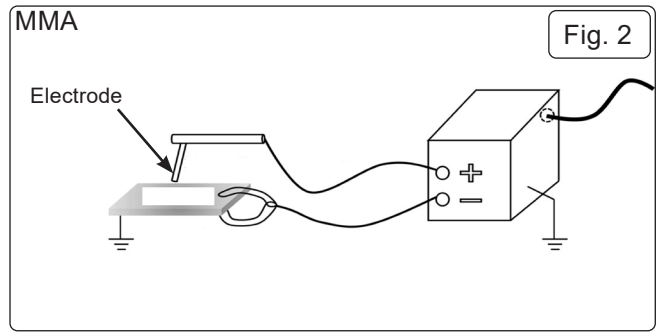
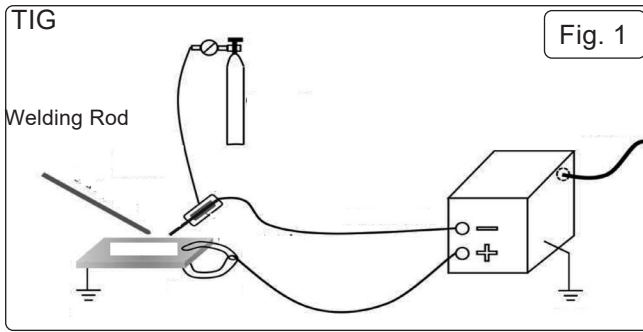

Key to Fig. 5		
ITEM	Description	Function
1	Mode Button	Select mode
2	LED	Power light
3	LED	Overheat indication
4	Display 1	Show the value of wire speed in MIG mode and current in MMA & TIG modes
5	Display 2	Show the value of voltage in MIG mode and arc force in MMA mode
6	Wire speed & current Knob	Adjust the value of wire speed in MIG mode and current in MMA & TIG modes
7	Voltage & arc force Knob	Adjust the value of voltage in MIG mode and arc force in MMA mode
8	Inductance Knob	Adjust the value of inductance
9	Inching button	Inching
10	Gas button	Gas check
11	2T/4T button	Select 2T/4T function
12	Wire diameter button	Select the diameter of wire in MIG mode
13	Material button	Select the material in MIG mode

## WIRE FEEDER CONTROL PANEL

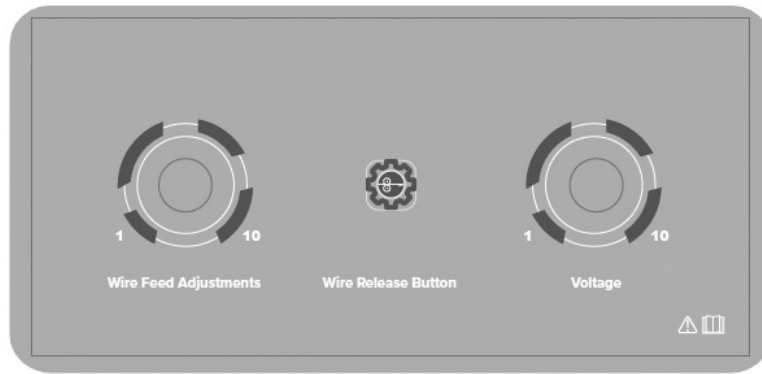

No	Name	Adjustments
1	Control knob 1	Adjust the wire feeding speed in MIGSYN & MIG modes
2	Inching button	Press for wire feeding before welding in MIGSYN & MIG mode
3	Control knob 2	Adjust the output voltage in MIGSYN & MIG modes

### 5.1. SHORT CIRCUIT PROTECTION

5.1.1. When a short circuit is detected, the machine will turn off the output current to avoid being in a high current output state all the time. Sometimes the output current may still exist, and the user should avoid short circuit between the electrode and the workpiece as much as possible, and do not get too close, especially the alkaline electrode. If there is a short circuit, it should be quickly removed from the short circuit state, and if necessary and convenient, it can be shut down first and then processed.

### 5.2. 2T / 4T

5.2.1. 2T/4T are two ways of on-off control of welders.  
2T/4T is commonly used for TIG, MIG, and PLASMA CUTTING.

5.2.2. 2T / 4T WORKING METHODS

2T	Press the welding torch and the machine starts to work; Release the torch and the machine stops working.
4T	Press the welding torch for the first time, and the machine enters the initial current; Loosen the welding torch, the machine enters the working current,; Press the welding torch again, the machine enters the end up current; Loosen again and the machine stops working.

### 5.3. PRE GAS AND POST GAS

5.3.1. Before starting the welding work, close the welding torch, and the machine will begin to deliver gas, which is the pre gas. The front air supply ensures that the welding is in a protective gas atmosphere and improves the welding quality.  
After the end of the welding, do not immediately remove the torch, the torch continues to transport a section of gas, which helps to reduce the temperature of the weldment surface, but also to avoid the high-temperature workpiece and air chemical reaction.

### 5.4. SYN—JUST FOR MIG/MAG

5.4.1. SYN means synergy. The essence of synergy is that after testing, we get suitable welding parameters, and write it into the software, when you need to query welding parameters, you do not need to ask and query, only need to select certain parameters on the panel, and the welding machine will recommend the appropriate welding current (and welding voltage).

5.4.2. However, everyone's feel and the speed of the welding machine vary, so although we recommend the current (and voltage), you can still adjust on this basis, only fine tuning is recommended.

### 5.5. MMA (ARC FORCE)

5.5.1. When the electrode is too close to the workpiece, the machine will increase the output current. The electrode will melt faster.

5.5.2. ARC FORCE helps prevent short circuits.

### 5.6. MIG/MAG (INDUCTANCE)

5.6.1. The hardness of welding arc can be changed by adjusting the inductance. The smaller the inductance value is, the harder the welding arc is and the bigger the splash is. The higher the inductance value, the softer the arc and the smaller the splash.

### 5.7. WELDING PROCEDURE

5.7.1. Specify the material to be welded, the thickness, and the welding mode to be used.

5.7.2. Select appropriate tooling for mode to be used (Section 5).

5.7.3. Connect the power line, gas, wire or electrode and welding/cutting torch, and turn on (see Fig.1, Fig.2, Fig.3, Fig.4)

5.7.4. Select the appropriate mode on the screen.

5.7.5. Adjust the current (or voltage, wire feed speed) to be used in welding or cutting.

5.7.6. Determine the process to be used when welding, such as 4T mode, pulse, etc.

5.7.7. Start welding or cutting.

5.7.8. During the welding process, the current or voltage, wire feed speed and process parameters can be adjusted according to the welding effect until a satisfactory welding effect is obtained.

5.7.9. For the machine with post gas function, when the welding work is finished, the welding torch should not leave the workpiece immediately, and the post gas should be completed.

× **DO NOT** immediately touch the workpiece and welding torch.

- 5.7.10. Turn off the power, turn off the gas, clean up the welding machine, and keep it safe.
- 5.8. MIG/MAG/FLUX CORED**
- 5.8.1. The diameter of the welding wire, the diameter wire feed wheel and the diameter of the conductive nozzle should be the same.
- 5.8.2. The nozzle at the head of the torch plays a protective role for the conductive nozzle, and confirm that it has been installed before welding.
- 5.8.3. WIRE FEEDER (Fig.6)**
- 5.8.4. Release idler arms by unscrewing the idler arm clamps (Fig.6)
- 5.8.5. Select the appropriate wire feed wheels for installation and fit to drive shaft using the supplied fittings.
- 5.8.6. Install a suitable diameter reel of suitable material by unscrewing the turn wheel and locating the reel onto the shaft.
- 5.8.7. Thread a suitable diameter of wire through the wire feed mechanism.
- 5.8.8. Lock idler arms using the clamps (Fig.6).
- 5.8.9. Adjust feed tensioner (Fig.6) as necessary.
- 5.8.10. Thermal control can be achieved adjusting either voltage, current or feed speed.

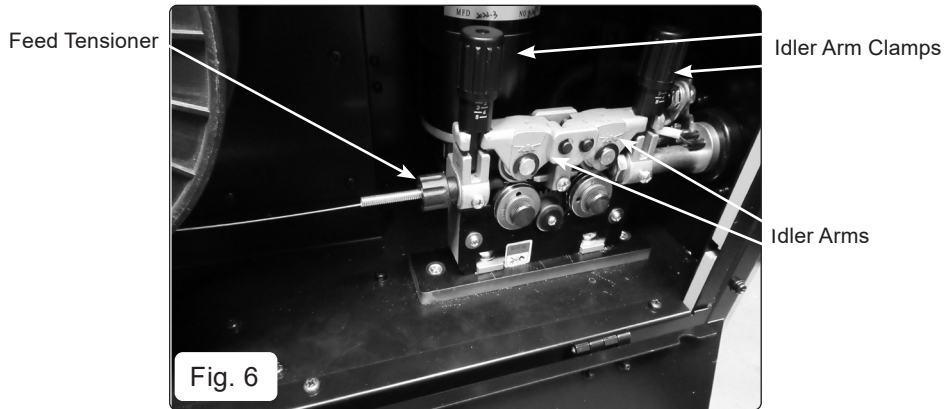

## 6. TROUBLESHOOTING

Fault	Description
E01/F01	Overheating
E02/F02	The input voltage is over or under voltage
E05/F05	Torch switch closed before turning on
E08/F08	Over current
E09/F09	The output is short-circuited or the voltage feedback line is abnormal
E10/F10	Closed torch, no output
E11/F11	Communication exception
E12/F12	The wire feeder is abnormal
E13/F13	Abnormal output current (output current less than set value)

Mode	Fault	Solution
All modes	E01/F01 overheating	Wait for the welder to cool down to return temperature, and then the welder will continue to work.
	E02/F02 Input voltage is too high or too low	Check the power supply and replace the power in a reasonable voltage
	E09/F09 Short-circuited	Firmly separate the welding torch from the workpiece and shut down the welding machine if necessary.
	Machine cannot be turned on	Check whether the input line is intact, whether the power is turned on, and whether the input voltage is normal
	E10/F10 Closed torch has no output	Check whether the ground cable and control cable are properly connected
	Gas leaks	Gas leaks can occur in welding machines, which can lead to poor quality welds. Check the gaslines and fittings for leaks, and tighten or replace any faulty connections. It's important to regularly inspect the gas lines and fittings for wear and tear, and replace them if necessary.
	Arc instability	Check the ground connection, adjust the settings according to the type of material being welded, and replace the electrode if necessary.
	The workpiece is welded Through	Reduce current.
MMA	Arcing difficulty	Increase the current; Increase HOT START; Dried electrode.
	Welding rod adhesion	Increase the current; Increase ARC FORCE.
	Welding arc break	Shorten the distance between the electrode and the workpiece, do not pull too high.
TIG	The weld colour is dark	Accelerate the speed of welding; <b>DO NOT</b> remove the torch immediately after welding; Turn up the pre gas and post gas.
	The tungsten needle burns Out quickly	Check wiring polarity.
	Irregular weld	Sharpen the tungsten needle.
	Weld failure	Increase current.

## 7. MAINTENANCE

- WARNING!** Disconnect from power supply before carrying out any maintenance procedures.
- ✗ **DO NOT** take apart the machine without permission, it may damage the machine.
- ✓ When moving the machine, make sure the power is off.
- ✗ **DO NOT** block the fan of the running machine or touch the fan position. Check the ventilation before each use.
- ✓ Always start by reading the manual for your specific welding equipment.
- ✓ Regularly clean your welding equipment to remove any dirt, debris, or metal shavings that could clog up the machinery. Use a soft brush or compressed air to clean any cooling fans, vents, or filters.
- ✓ Inspect the welding cables regularly for any damage or wear and tear. Replace any cables that show signs of damage, such as fraying, s, or cracks.
- ✓ Check the consumables, such as tips, nozzles, and electrodes, regularly for wear and tear. Replace any consumables that are damaged or worn out. Using damaged consumables can negatively affect the quality of your welds.
- ✓ Check the gas cylinder regularly for pressure and leaks. Replace the gas cylinder if it is empty or damaged.
- ✓ When not in use, store your welding equipment in a clean, dry, and safe location. Keep the equipment covered to protect it from dust, moisture, and other environmental factors.
- ✓ Check the welding machine output wiring specifications, firmness, and the cable connection screws for rust and oxidation.
- ✗ **DO NOT** short-circuit the conductive nozzle and the workpiece. The short circuit will burn out the conductive nozzle. Once burned out, it needs to be replaced, otherwise it will affect the welding quality.
- WARNING!** Ensure the unit is disconnected from the mains power supply before performing any maintenance or service.
- ✓ Regularly check all welding cables and secondary terminals to ensure they are in good order and connected correctly, also check during welding to ensure they are not overheating.
- ✓ Check that the gas hose connections are tight and that there are no gas leaks.

### 7.1. WIRE FEED UNIT

- 7.1.1. Check the wire feed unit at regular intervals. The feed roller wire guide plays an important part in obtaining consistent results. Poor wire feeding affects welding. Clean the rollers weekly, especially the feedroller groove, removing all dust deposits from the feeder area.
- 7.1.2. CHANGING FEED ROLLER / ROLLERS IMPORTANT: Set up the feed rollers according to the wire size required for the job in hand.

### 7.2. TORCH

- 7.2.1. Protect torch cable assembly from mechanical wear. Also do not allow the torch or its cable to come into contact with hot surfaces, especially a hot workpiece as this would cause the insulating materials to melt, making the torch unsafe and unusable.
- 7.2.2. Make regular checks on the gas pipe and connector seals.
- 7.2.3. Every time the wire reel is changed, blow out the wire-guide hose using dry compressed air (max. 5 bar) to make sure it is not damaged;
- 7.2.4. Before using the welding machine, always check the torch terminal parts for wear and make sure they are assembled correctly: nozzle, contact pipe, gas diffuser.

- 7.3. **CONTACT TIP** The contact tip is a consumable item and must be replaced when the hole becomes enlarged or oval. The contact tip **MUST** be kept free from spatter to ensure an unimpeded flow of gas.

#### 7.4. GAS CUP

7.4.1. To keep the contact tip free from spatter, we recommend the use of Sealey anti-spatter spray (MIG/722307) available from your Sealey stockist.

#### 7.5. INTERNAL MAINTENANCE / INSPECTION

INTERNAL INSPECTION AND MAINTENANCE OPERATIONS SHOULD BE CARRIED OUT ONLY AND EXCLUSIVELY BY SKILLED OR AUTHORISED ELECTRICAL/MECHANICAL TECHNICIANS.

- **WARNING:** BEFORE REMOVING THE WELDING MACHINE PANELS AND WORKING INSIDE THE MACHINE MAKE SURE THE WELDING MACHINE IS SWITCHED OFF AND DISCONNECTED FROM THE MAIN POWER SUPPLY OUTLET.

7.5.1. If checks are made inside the welding machine while it is live, this may cause serious electric shock due to direct contact with live parts and/or injury due to direct contact with moving parts.

7.5.2. Inspect the welding machine regularly, with a frequency depending on use and the dustiness of the environment, and remove the dust deposited on the transformer, reactance and rectifier using a jet of dry compressed air (max. 10 bar).

7.5.3. **DO NOT** direct the jet of compressed air on the electronic boards; these can be cleaned with a very soft brush or suitable solvents.

7.5.4. At the same time make sure the electrical connections are tight and check the wiring for damage to the insulation.

7.5.5. At the end of these operations re-assemble the panels of the welding machine and screw the fastening screws right down.

- **WARNING:** Never, ever carry out welding operations while the welding machine is open.

### 8. END OF LIFE

8.1. Dispose of unit and accessories in accordance with Local and National regulations, WEEE Regulations and Environment Protection footers.

### 9. POWERMIG500WI EXTRAS

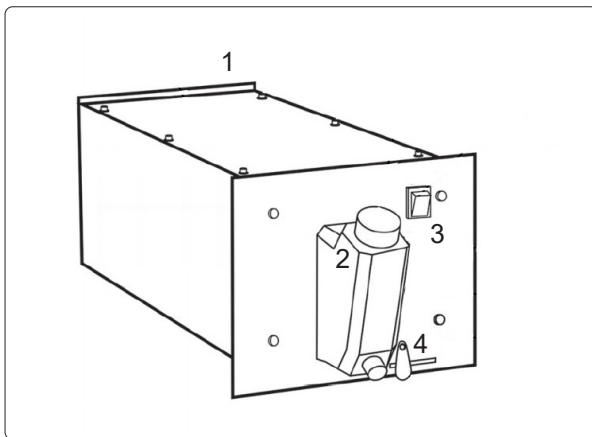

1. Metal housing
2. Cooling liquid tank
3. On/Off button
4. Fixed key

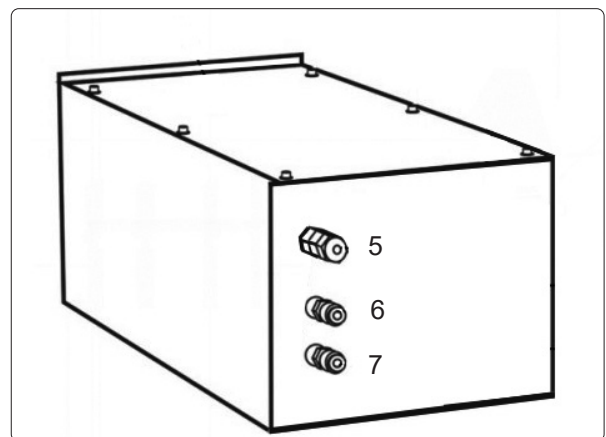

5. Signal connector
6. Cooling liquid outlet connector 1
7. Cooling liquid outlet connector 2

### 10. WATER FUNCTIONS

- 10.1.1. Increase the stable operating time of welding inverters.
- 10.1.2. Provide high voltage within a range of 17 meters.
- 10.1.2.1. The cooler casing is corrosion-resistant.
- 10.1.3. Low noise.
- 10.1.4. Easy to operate.
- 10.1.5. Improve the performance and durability of welding machines.

Power / W	370
Required current / A	0.3-0.6
Maximum pressure / kg/cm <sup>2</sup>	3
Feed rate / L/min	8
Power supply voltage / V	230 (1 phase)
Operating conditions / °C	-20 -- 40
Tank capacity / L	6
Coolant	Distilled water (at negative temperature - antifreeze)
Protection level	IP21
External dimensions / mm	580 * 265 * 288
Weight / kg	15



## 11. DESIGN AND WORKING PRINCIPLE

- 11.1. Liquid cooling is suitable for intensive work and high-temperature environments. For example, if the environment is +30 ° C or higher, the hot air circulation is not sufficient to cool the equipment. In addition to the fan, a liquid cooling system (coolant tank) is also installed. It contains a liquid or distilled water with special chemical components. Due to the circulation of coolant through the machine and welding burner, it ensures continuous operation and cooling. This cooling method also optimizes the cooling of the welding burner. It is important to remember that this type of equipment uses liquid cooled welding burners!
- 11.2. The main requirements for liquid cooling systems are:
- 11.2.1. The level of coolant must be monitored. If the liquid decreases, the equipment and burner will not have sufficient cooling.
- 11.2.2. It is prohibited to mix liquids from different manufacturers together because The device may fail due to different chemical compositions
- 11.2.3. Regularly check the quality of the liquid.

## 12. EQUIPMENT CONNECTION

- 12.1. Remove the device from the packaging.
- 12.2. Check the integrity of the equipment and accessories before use.
- 12.3. Open the filling cap (hole) to ensure that the water tank is clean. Although the water tank and liquid itself are completely isolated from the environment, sometimes the system may malfunction
- 12.4. The cooling process is filled with dirt. Dirt may enter liquids for various reasons, such as pouring liquids from dirty containers. If dirt enters the liquid, it may interfere with the pump's operation and needs to be cleaned.
- 12.5. Install the liquid cooling system on the welding machine trolley instead of the toolbox and connect it to the welding machine.
- 12.6. Connect the water circulation pipe from the cooling device to the wire supply device. It is important to connect the pipes according to colour, from blue to blue and from red to red. The blue circuit is the output circuit of the cooling water after the radiator, and the red circuit is the output circuit. The hot water is discharged from the power cable of the burner.
- 12.7. Protect it from direct water and sunlight.
- 12.8. Ensure that there is sufficient space for air circulation in front and behind the equipment.
- 12.9. Connect the water cooling device cable to the power grid.
- 12.10. If necessary, use accessories to connect the water supply hose to the connector.
- 12.11. Input, output. Connect the outlet of the liquid cooling unit to the inlet of the burner, and connect the outlet of the burner to the inlet of the liquid cooling unit.
- 12.12. Fill the water tank with water. Another type of antifreeze can also be used. When using alcohol, the ratio of distilled water is 90% and 10%.
- 12.13. Control the pouring level of the semi transparent protruding part of the fuel tank.
- 12.14. Turn on the power.
- 12.15. Disconnect the inlet connector of the liquid cooling device, ensure that the water circuit of the burner is filled with water, and liquid flows out from the outlet of the burner. Tighten the joint.
- 12.16. The device is ready.
- 12.17. Check the liquid level and refill if necessary.
- 12.18. If the liquid level drops or the hose is blocked or damaged, welding is not allowed.

## 13. MAINTENANCE

### 13.1. DAILY MAINTENANCE

- 13.1.1. List of required conditions for daily execution:
- 13.1.2. Check the water level (if necessary, top up with liquid).
- 13.1.3. Check the cables and connections. Tighten them or replace damaged parts.

### 13.2. MAINTAIN EVERY SIX MONTHS

- 13.2.1. These conditions must be met every six months
- 13.2.2. Clean the dust and dirt in the equipment. Replace the coolant and clean the pipes and water tank with clean water.

## 14. TROUBLE SHOOTING

FAULT	SOLUTIONS
Pump running	No liquid enters; Canal blockage; -Blow or replace blocked channels with compressed air.
Pump cavitation	Check the sealing and water level of the joint or replace the pump membrane.
Pump malfunction	Check the power supply voltage and fuses.

## 15. RATING PLATE

On the front panel of the welder is the ratings plate, giving the following data:

- 1 - The BS/EU standard relating to the safety and construction of arc welding and associated equipment.
- 2 - Single phase transformer.
- 3 - Symbol indicates welding with a continuous flow of welding wire.
- 4 - Symbol for three-phase AC supply.
- 5 - Rating of internal protection provided by casing.
- 6 - Output U0 Rated minimum and maximum no load voltage.
- I2, U2 Current and corresponding voltage.
- X Welding ratio based on a 10 minute cycle.
- 20% indicates 2 minutes welding and 8 minutes rest, 100% would indicate continuous welding.
- 7 - Mains Supply
- U1 Rated supply voltage and frequency.
- I1max Maximum current.
- I1eff Maximum effective current.
- 8 - Welding current range.
- 9 - Serial Number. Specifically identifies each welder

SEALEY		INVERTER WELDING MACHINE	
2	Model No. POWERMIG500Wi	EN IEC 60974-1	EN IEC 60974-10
3		50A/22V to 500A/40V	
		X	60% 100%
		I <sub>2</sub>	500A 388A
		U <sub>2</sub>	35.6V
		I <sub>1max</sub>	39.5A
		I <sub>1eff</sub>	30.6A
6		50A/12V to 500A/30V	
		X	60% 100%
		I <sub>2</sub>	500A 388A
		U <sub>2</sub>	25.6V
4		I <sub>1max</sub>	32A
		I <sub>1eff</sub>	24.8A
7		30A/15.5V to 500A/39V	
		X	60% 100%
		I <sub>2</sub>	500A 388A
		U <sub>2</sub>	33.4V
		I <sub>1max</sub>	40A
5		I <sub>1eff</sub>	31A
	IP21S Kempson Way, Bury St Edmunds, Suffolk, IP32 7AR, UK.		

SEALEY		INVERTER WELDING MACHINE	
2	Model No. POWERMIG500i	EN IEC 60974-1	EN IEC 60974-10
3		50A/22V to 500A/40V	
		X	60% 100%
		I <sub>2</sub>	500A 388A
		U <sub>2</sub>	35.6V
		I <sub>1max</sub>	39.5A
		I <sub>1eff</sub>	30.6A
6		50A/12V to 500A/30V	
		X	60% 100%
		I <sub>2</sub>	500A 388A
		U <sub>2</sub>	25.6V
4		I <sub>1max</sub>	32A
		I <sub>1eff</sub>	24.8A
7		30A/15.5V to 500A/39V	
		X	60% 100%
		I <sub>2</sub>	500A 388A
		U <sub>2</sub>	33.4V
		I <sub>1max</sub>	40A
5		I <sub>1eff</sub>	31A
	IP21S Kempson Way, Bury St Edmunds, Suffolk, IP32 7AR, UK.		



### WEEE REGULATIONS

Dispose of this product at the end of its working life in compliance with the EU Directive on Waste Electrical and Electronic Equipment (WEEE). When the product is no longer required, it must be disposed of in an environmentally protective way. Contact your local solid waste authority for recycling information.



### ENVIRONMENT PROTECTION

Recycle unwanted materials instead of disposing of them as waste. All tools, accessories and packaging should be sorted, taken to a recycling centre and disposed of in a manner which is compatible with the environment. When the product becomes completely unserviceable and requires disposal, drain any fluids (if applicable) into approved containers and dispose of the product and fluids according to local regulations.

**Note:** It is our policy to continually improve products and as such we reserve the right to alter data, specifications and component parts without prior notice.

**Important:** No Liability is accepted for incorrect use of this product.

**Warranty:** Guarantee is 12 months from purchase date, proof of which is required for any claim.



REGISTER YOUR PURCHASE HERE

Sealey Group, Kempson Way, Suffolk Business Park, Bury St Edmunds, Suffolk. IP32 7AR



01284 757500



sales@sealey.co.uk



www.sealey.co.uk