

Thank you for purchasing a Sealey product.
 Manufactured to a high standard this item will give you years of trouble free performance if these instructions are carefully followed and the product is correctly maintained.



IMPORTANT: PLEASE READ THESE INSTRUCTIONS CAREFULLY. NOTE THE SAFE OPERATIONAL REQUIREMENTS, WARNINGS AND CAUTIONS. USE THIS PRODUCT CORRECTLY AND WITH CARE FOR THE PURPOSE FOR WHICH IT IS INTENDED. FAILURE TO DO SO MAY CAUSE DAMAGE AND/OR PERSONAL INJURY AND WILL INVALIDATE THE WARRANTY. PLEASE RETAIN THESE INSTRUCTIONS FOR FUTURE USE.

1. SAFETY INSTRUCTIONS

1.1. ELECTRICAL SAFETY

REGARDING DIRECT MAINS POWER USE OF THE CHARGING UNIT. (See fig.4)

- WARNING!** It is the responsibility of the owner and the operator to read, understand and comply with the following: You must check all electrical products, before use, to ensure that they are safe. You must inspect power cables, plugs, sockets and any other connectors for wear or damage. You must ensure that the risk of electric shock is minimised by the installation of appropriate safety devices. A Residual Current Circuit Breaker (RCCB) should be incorporated in the main distribution board. We also recommend that a Residual Current Device (RCD) is used. It is particularly important to use an RCD with portable products that are plugged into a supply which is not protected by an RCCB. If in any doubt consult a qualified electrician. You may obtain a Residual Current Device by contacting your Sealey dealer. You must also read and understand the following instructions concerning electrical safety.
- 1.1.1. The **Electricity at Work Act 1989** requires that all portable electrical appliances, if used on business premises, are tested by a qualified electrician, using a Portable Appliance Tester (PAT), at least once a year.
- 1.1.2. The **Health & Safety at Work Act 1974** makes owners of electrical appliances responsible for the safe condition of those appliances and the safety of the appliance operators. **If in any doubt about electrical safety, contact a qualified electrician.**
- 1.1.3. Ensure that the insulation on all cables and on the charger is safe before connecting it to the power supply. See 1.1.1. and 1.1.2. and use a Portable Appliance Tester.
- 1.1.4. Ensure that cables are always protected against short circuit and overload.
- 1.1.5. Regularly inspect the power supply cable and plug for wear or damage and check all connections to ensure that none is loose.
- 1.1.6. **Important:** Ensure that the voltage marked on the appliance matches the power supply to be used and that the plug is fitted with the correct fuse - see fuse rating at (BELOW) right.
- 1.1.7. **DO NOT** pull or carry the appliance by the power cable.
- 1.1.8. **DO NOT** pull the plug from the socket by the cable.
- 1.1.9. **DO NOT** use worn or damaged cables, plugs or connectors. Immediately have any faulty item repaired or replaced by a qualified electrician. When a BS 1363/A UK 3 pin plug is damaged, cut the cable just above the plug and dispose of the plug safely. Fit a new plug according to the following instructions (UK only).

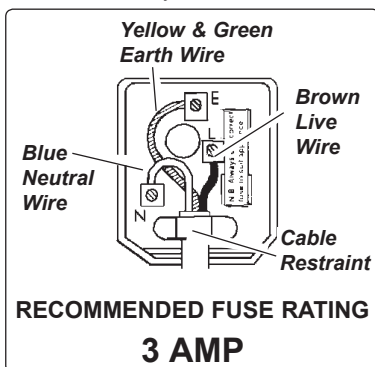

- a) Connect the **GREEN/YELLOW** earth wire to the earth terminal 'E'.
- b) Connect the **BROWN** live wire to the live terminal 'L'.
- c) Connect the **BLUE** neutral wire to the neutral terminal 'N'.
- d) **After wiring, check that there are no bare wires, that all wires have been correctly connected, that the cable outer insulation extends beyond the cable restraint and that the restraint is tight.**

Double insulated products, which are always marked with this symbol , are fitted with live (brown) and neutral (blue) wires only. To rewire, connect the wires as indicated in diagram. **DO NOT** connect either wire to the earth terminal.

1.2. GENERAL SAFETY

- ✓ Read the vehicle handbook to check for any specific battery charging information.
- ✓ This unit must only be used on systems running on 12V or 24V only.
- ✓ This unit is intended for use in emergencies only. Do not use the starter instead of the vehicle battery. Use it during start-up operations only.
- x Avoid contact with battery acid. If an operator comes into contact with the acid, rinse affected parts immediately under clean running water. Continue to rinse the area until medical help arrives.
- ✓ Wear approved safety eye protection i.e. goggles (standard spectacles are not adequate).
- WARNING!** Ensure that there are no sources of flammable ignition near the work area i.e. naked flames, cigarettes, flame heaters, etc. as lead acid batteries produce explosive gases.
- x **DO NOT** allow the starter terminal clamps to touch each other when the power is on. Remember that gases are produced which may ignite if sparks occur. To minimise accidental contact, disconnect the mounting socket (12V/24V) from the starter panel and place the battery clamps in the storage pocket on the front of the unit.
- WARNING!** Ensure that the work area is well ventilated as the gases produced are flammable.
- x **DO NOT** work alone. In case of an accident have someone at hand to help.
- ✓ Maintain the starter in good condition (use an authorised service agent only).
- ✓ Keep the starter clean for best and safest performance.
- ✓ Locate the starter in a suitable work area and keep the area clean and tidy and free from unrelated materials. Ensure adequate lighting.
- ✓ Remove ill fitting clothing. Remove ties, watches, rings and other loose jewellery and contain long hair.
- WARNING!** Disconnect the mains power before servicing or performing any maintenance.
- ✓ Disconnect from the mains power before connecting to, or disconnecting from, the battery.
- ✓ Clean clamps and battery terminals, removing any oxidation before connecting the starter to the battery.
- ✓ Ensure that the correct polarity clamp is attached to the correct terminal of the battery. POSITIVE is indicated by (+) and may be red, NEGATIVE is indicated by (-) and may be black. If there are no identifiable symbols, you can distinguish the NEGATIVE battery terminal as the one which is connected from the battery directly to the vehicle body. **(For negative earth vehicles only, for positive Earth vehicles consult the vehicle handbook for the correct connection procedure.)**
- x **DO NOT** use any other type of Charger Unit other than the one supplied to charge the starter unit.
- x **DO NOT** use the Charger Unit to charge any other electrical item.
- x **DO NOT** get the Charger Unit wet, or use in wet, damp conditions (for indoor use only).
- x **DO NOT** operate the Charger Unit if it has been dropped, or has received a sharp knock, or is damaged. Contact an authorised service agent.
- x **DO NOT** try to open or dis-assemble the Charger Unit as this may cause damage or personal injury and will invalidate your warranty.

- ✓ Keep children and unauthorised persons away from the work area.
- x **DO NOT** use the starter for any purpose other than that for which it is designed.
- x **DO NOT** allow untrained persons to operate the starter.
- x **DO NOT** get the starter wet or use in damp or wet locations or areas where there is condensation.
- x **DO NOT** operate the starter if it is damaged.
- x **DO NOT** attempt to open or modify the starter.
- ✓ When not in use store in a safe, dry, child proof area. Store under lock and key.
- x **DO NOT** expose to direct sunlight, heat sources, or humidity.
- ✓ Ensure that the unit is in a stable position before commencing use.
- ✓ Check the condition of cables on a regular basis and if any are damaged have them repaired or replaced by a qualified technician.
- ✓ Before use check for damaged parts and have any faulty items replaced with authorised parts only. Check that the cables are securely fastened to the starter.
- **WARNING!** *Be vigilant and cautious during the starting procedure as battery acid is highly corrosive and gases can be emitted during the starting process that are flammable and harmful to health.*
- ✓ Avoid electric shocks. Be very cautious when attaching the clamps to non-insulated conductors or bus bars. Avoid all body contact with the surfaces of tubes, radiators and metal power substations while testing the voltage.

2. INTRODUCTION & SPECIFICATION

DESCRIPTION.

Heavy-duty steel case with composite front storage panel. Features a high powered manufactured battery making this model suitable for starting most vehicles. Large, easy to read analogue battery indicator provides fast indication of battery's state of charge. Heavy-duty copper cables provide efficient power transfer. Built in trip to prevent damage to battery or internal circuitry. Surge and spike suppressing circuitry reduces risk of damaging vehicle's on-board electronics. Supplied with mains voltage recharging pack. Supplied with two heavy-duty rear wheels for easy manoeuvrability.

Model No:	PWRSTART4400
Output Voltage	12/24V
Maximum Engine Size	400hp
Peak Amps 12V	4400A
Peak Amps 24V	2200A
Cranking Current (20° 5secs) 12V:.....	1600A
Cranking Current (20° 5secs) 22V:.....	800A
Cold Cranking Current (-18°C 30secs) 12V:.....	750A
Cold Cranking Current (-18°C 30secs) 24V:.....	350A
Cable size	16mm ²
Cable & Clamp Length.....	1.72mtr
Weight.....	.40kg

3. ASSEMBLY

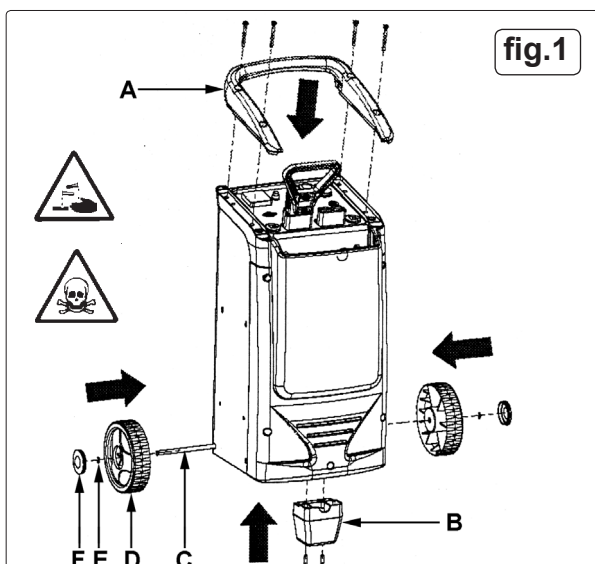

3.1 ASSEMBLY.

- 3.1.1 **HANDLE MOULDING.** Attach the handle moulding (A) to the top of the unit as shown in fig.1 using the four 50mm self tapping screws provided. Do not overtighten.
- 3.1.2 **WHEELS.** Lower the unit carefully onto its front face on a clean, non abrasive surface.
- 3.1.3 Slide the chrome axle rod (C) through the holes in the rear lower corners of the cabinet so that it projects equally either side.
- 3.1.4 Place a wheel (D) onto each end of the axle. Retain the wheels by attaching a circlip (E) to each end of the axle.
- 3.1.5 Firmly press a plastic plug (F) into each wheel recess.
- 3.1.6 **FRONT FOOT.** Attach the front foot (B) to the underside of the unit using the two 25mm self tapping screws provided. Do not over tighten.
- 3.1.7 Lift the unit into the upright position.
- 3.1.8 **MOUNTING SOCKET.** Referring to fig.2 attach the handle (A) to the mounting socket (B) in the orientation shown using the nuts, bolts and washers provided.

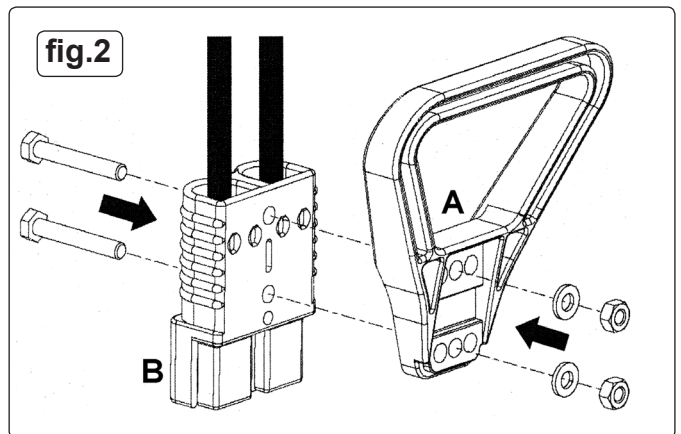

4. OPERATION

□ **WARNING!** Electrical shock can cause death or injury. Avoid touching exposed conductors of electricity. This unit is designed for use with vehicle or boats. You will not need a host vehicle or 230VAC power supply (Except for recharging the unit after use). You can also use this system as a portable power source of 12VDC in remote areas or emergencies.

4.1 Using the starter to start a vehicle.

- 4.1.1 Check that the starter clamps are NOT powered up by ensuring that the mounting socket (fig.3-1) is disconnected.
- 4.1.2 Make sure that the ignition switch of the vehicle or boat to be started is in the OFF position.
- 4.1.3 Connect the red clamp (+) to the positive terminal on the vehicle's battery.
- 4.1.4 Connect the black clamp (-) to a non moving metal part of the engine, do not connect the clamp to the negative terminal on the battery.
- 4.1.5 **Before connecting the mounting socket (fig.3-1) make the following checks:**
 - a) Check the voltage required for the vehicle to be started.
 - b) Ensure the red and black clamps are correctly connected to avoid a reverse polarity situation.
- 4.1.6 Plug the mounting socket onto the 12V or 24V supply, according to the voltage required by the vehicle to be started.
- 4.1.7 Turn the ignition switch (or key) of the vehicle or boat to ON. Wait for one minute. Turn the engine over for no more than 5 to 6 seconds. If the vehicle or boat engine does not start, wait at least 3 minutes before retrying.
- 4.1.8 When engine is running, always disconnect the starter in the following order:
 1. Disconnect the mounting socket from the starter (starter OFF).
 2. Disconnect the black (negative) clamp from the vehicle.
 3. Disconnect the red (positive) clamp from the vehicle.
 4. Return the clamps to their housing.

NOTE! Recharge the starter as soon as possible.

- **WARNING!** Never allow the red and black clamps to touch each other or a common conductor.

4.2 Using the starter as a 12V power supply.

- 4.2.1 Fold back the protective rubber plug from the accessory socket (fig.3-4).
- 4.2.2 Insert the accessory plug of the appliance to be powered into the socket.
- 4.2.3 In case of overload the re-settable safety switch will trip. (fig.3-6) Investigate and remedy the cause of the overload before pushing the reset button.

4.3 Recharging the starter.

IMPORTANT! To protect the battery and lengthen its working life, charge it for 12 hours before using it for the first time, then after every time it is used, and in any case, at least every three months.

- 4.3.1 Recharge the unit using the 230V AC power adaptor supplied. See fig.4. We recommend keeping the batteries fully charged at all times. A low charge level could shorten the life of the battery. Bear in mind that the time required to recharge the battery will depend on the number of times it has been used.
WARNING: Use the supplied charger only and exclusively to charge the starter.
- 4.3.2 Insert the charger mains plug (see fig.4) into the mains supply.
- 4.3.3 Insert the charger output plug (see fig.4) into the charging socket on the control panel. See fig.3-2.
- 4.3.4 Leave the starter to charge for about 8 hours.
- 4.3.5 Check the battery charge level by pressing the red 'TEST' button (fig.3-5). The voltmeter (fig.3-3) indicates the battery charge level.
- 4.3.6 When the voltmeter indicator needle is in the green area of the scale the battery is charged.
- 4.3.7 Now unplug the charger from the unit and the mains plug from the mains supply.

NOTE: The starter has a device for monitoring the charge status of the batteries. When charging is complete the charger automatically resets itself and can therefore remain connected for as long as desired.

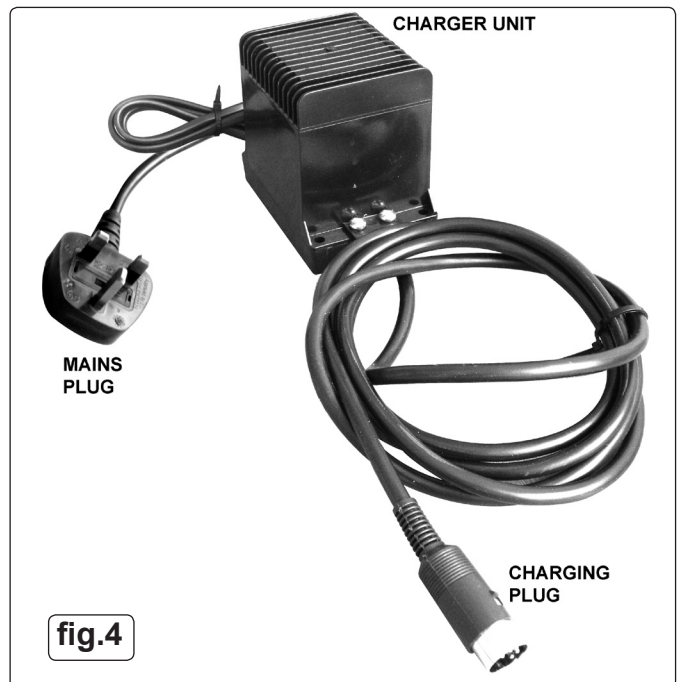
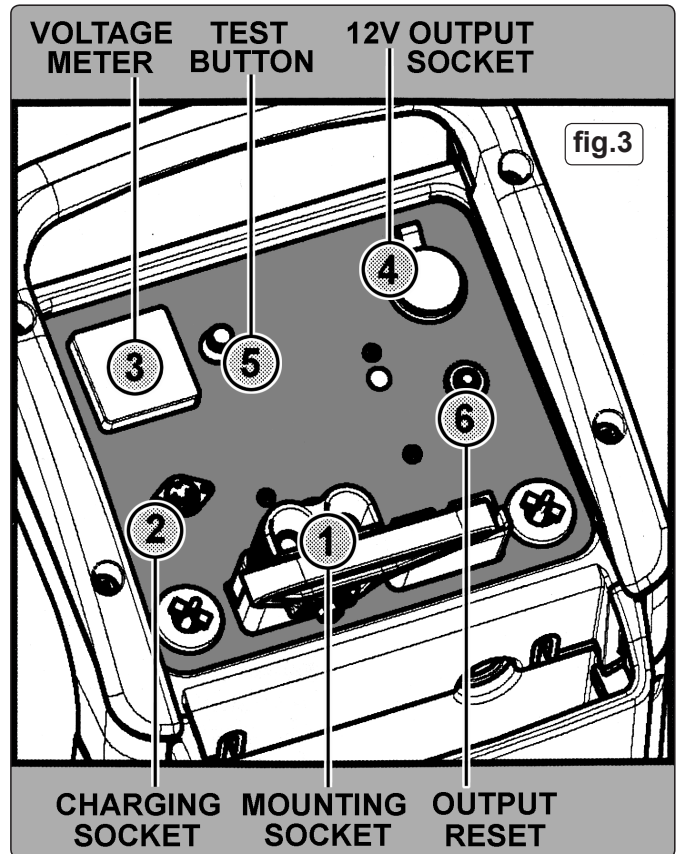

Environmental Protection

Recycle unwanted materials instead of disposing of them as waste. All tools, accessories and packaging should be sorted, taken to a recycle centre and disposed of in a manner which is compatible with the environment. When the product is no longer required, it must be disposed of in an environmentally protective way. Contact your local authority for recycling information.



Battery Removal

At the end of its working life the batteries should be removed from the unit by a qualified electrician and be **disposed according to local authority guidelines.**

WARNING: Do not dispose of by fire. This could result in an explosion.



Under the Waste Batteries and Accumulators Regulations 2009, Jack Sealey Ltd are required to inform potential purchasers of products containing batteries (as defined within these regulations), that they are registered with Valpak's registered compliance scheme. Jack Sealey Ltd's Batteries Producer Registration Number (BPRN) is BPRN00705.

Parts support is available for this product. To obtain a parts listing and/or diagram, please log on to www.sealey.co.uk, email sales@sealey.co.uk or phone 01284 757500.

NOTE: It is our policy to continually improve products and as such we reserve the right to alter data, specifications and component parts without prior notice.

IMPORTANT: No liability is accepted for incorrect use of this product.

WARRANTY: Guarantee is 12 months from purchase date, proof of which will be required for any claim.

INFORMATION: For a copy of our latest catalogue and promotions call us on 01284 757525 and leave your full name and address, including postcode.



Sole UK Distributor, Sealey Group,
Kempson Way, Suffolk Business Park,
Bury St. Edmunds, Suffolk,
IP32 7AR



01284 757500



www.sealey.co.uk



01284 703534



sales@sealey.co.uk