



PRESSURE WASHER 220bar 10ltr/min

6.5hp PETROL

MODEL NO: PWM2500

Thank you for purchasing a Sealey product. Manufactured to a high standard, this product will, if used according to these instructions, and properly maintained, give you years of trouble free performance.

IMPORTANT: PLEASE READ THESE INSTRUCTIONS CAREFULLY. NOTE THE SAFE OPERATIONAL REQUIREMENTS, WARNINGS & CAUTIONS. USE THE PRODUCT CORRECTLY AND WITH CARE FOR THE PURPOSE FOR WHICH IT IS INTENDED. FAILURE TO DO SO MAY CAUSE DAMAGE AND/OR PERSONAL INJURY AND WILL INVALIDATE THE WARRANTY. KEEP THESE INSTRUCTIONS SAFE FOR FUTURE USE.



Refer to instructions



Wear ear protection



Wear eye protection

WARNING: The engine is shipped without oil. The pump is shipped with oil. Therefore only the engine must be filled with the correct type and quantity of oil.
See section 3 for Oil specifications

1. SAFETY

1.1. GENERAL SAFETY

- WARNING! RISK OF FLUID INJECTION.** This washer operates at fluid pressures and velocities high enough to penetrate human and animal flesh. ***If there is an occurrence of fluid injection seek medical help immediately***
- WARNING!** Stop the engine and disconnect the mains water supply before changing accessories or performing any maintenance.
- WARNING! Do not operate** the washer if damaged. Replace or repair using recommended parts only. Unauthorised parts may be dangerous and will invalidate your warranty. Use authorised Service agent only.
- ✓ Keep the washer in good condition. Regular maintenance will give the best and safest performance.
- ✓ Ensure you comply with the water supply company regulations before connecting to the mains. If you are connecting to the mains drinking water supply ensure you have a back flow preventer valve installed.
- ✓ The water supply hose must be reinforced and have an internal diameter of 13mm (1/2"). The minimum water supply rate must be at least equal to the cleaner capacity. The water temperature must not exceed 50°C and the pressure must not exceed 10bar.
- WARNING! DO NOT** operate the washer without the water supply connected. To do so will damage the machine.
- ✓ Position the washer as near as possible to the mains water supply.
- ✓ Only use recommended washing detergents. Failure to do so may cause corrosion to equipment and hoses.
- WARNING!** Use the washer on a flat, level surface, in a horizontal position. Failure to do so will invalidate your warranty.
- ✓ Wear safety goggles and adequate protective clothing and anti-slip rubber soled footwear.
- WARNING!** The high pressure jet must be used with caution. Ensure you aim the lance correctly at the work surface. Failure to do so may scatter loose particles at the same force as the water pressure, resulting in possible damage or personal injury.
- ✓ Keep all persons and animals at a safe distance from the hose working area. It is difficult to give an exact safe distance as it will depend upon your circumstances. We recommend at least 15 metres (16 yards). Also ensure other persons are aware before you start to depress the washer trigger.
- ✓ Hold the gun firmly for it will tend to "kick" backwards when you first pull the trigger.
- ✗ **DO NOT** allow children or untrained persons to operate the washer.
- ✗ **DO NOT** connect other appliances to the washer inlet or outlet. Only use the supplied or recommended outlet nozzle.
- ✗ **DO NOT** use the washer if the water supply hose is damaged. Also check that the hose is laid out straight and safely.
- ✗ **DO NOT** jam the operating trigger in the operating position, and **DO NOT** pull the trigger without holding and aiming the gun correctly.
- WARNING! DO NOT** attempt to alter the pressure regulating valve as this may cause serious damage.
- ✗ **DO NOT** move the washer by pulling on the high pressure hose or the mains water supply hose. Use the machine handle.
- ✗ **DO NOT** direct jet against yourself, other persons or animals, electrical equipment or the machine itself.
- WARNING! DO NOT** leave the engine running for more than 2 minutes without operating the trigger, as temperature/pressure increase may damage the sealing system.
- ✗ **DO NOT** use the washer if you are tired or under the influence of alcohol, drugs or intoxicating medication.
- ✓ Ensure that the hose pressure is discharged before disconnecting the mains water hose.
- ✓ When not in use, disconnect from the water supply. Clean and dry the washer and store in a safe, dry, childproof area.
- ✗ **DO NOT** allow the machine to become frozen.

1.2. ENGINE SAFETY

- WARNING! Check the engine oil level before each startup.** Only use an approved oil and never operate the engine with insufficient oil.
- WARNING! DO NOT touch spark plug or plug lead whilst the engine is running; severe, potentially fatal, electric shock may result.**
- ✓ For safety instructions relative to the maintenance and use of the petrol engine refer to the engine instruction manual.
- ✓ Ensure that only the correct fuel type and grade is used.
- ✗ **DO NOT** check ignition system by removing the spark plug or spark plug lead. Use specific tester or contact service agent.
- ✗ **DO NOT** operate the washer in an enclosed area as the motor exhaust fumes are a health hazard.
- ✗ **DO NOT** use the washer with flammable, toxic or corrosive liquids.
- ✗ **DO NOT** leave the washer unattended whilst operating and **DO NOT** remove the fuel cap whilst the engine is running.
- ✗ **DO NOT** refuel the engine whilst it is running. Stop the engine and allow it to cool for two minutes before attempting to refuel.
- ✗ **DO NOT** refuel in a closed or poorly ventilated environment as there is a danger of explosion or fire. Refuel outdoors.
- ✗ **DO NOT** smoke or place the washer near any naked flames whilst re-fuelling.
- ✗ **DO NOT** operate washer if there is a fuel leak. Move the unit and avoid using until the leak has been fixed and the machine is dry.

- × **DO NOT** start the engine if there are any flammable materials near the exhaust system or in the path of the exhaust gases.
 - × **DO NOT** block the engine ventilation grilles.
 - ✓ Ensure engine fuel is stored in an approved container.
 - ✓ For long term storage ensure the fuel is drained and that the washer is adequately protected against frost.
 - × **DO NOT** operate the engine with either the silencer or air filter removed.
 - × **DO NOT** touch the engine during or after use. To avoid burns allow it to cool before handling.
 - **WARNING!** The warnings referred to in this guide cannot cover all possible conditions and situations that may occur. It must be understood that common sense and caution are factors which cannot be built into this product, but must be applied by the operator.
- NOTE: This appliance is not intended for use by persons (including children) with reduced physical, sensory or mental capabilities or lack of experience and knowledge, unless they have been given supervision or instruction concerning the use of the appliance by a person responsible for their safety. Children should be supervised to ensure that they do not play with the appliance.

2. INTRODUCTION

Petrol powered pressure washer with recoil starting. Ideal for commercial applications with 5mtr pressure hose, 1mtr gun and lance and adjustable nozzle. Low-pressure liquid detergent injection system with provision for detergent bottle stowage. Safety latch on trigger and automatic low-oil engine shutdown reduce risks of misuse and equipment damage. Unit stands on four legs, two with sucker feet to prevent creep, and tilts back onto two pneumatic tyred wheels for moving. Supplied with tools and full Instructions.

3. SPECIFICATION

MODEL NO:PVM2500
Output Pressure:175bar/2538psi
Flow Rate:10ltr/min
Hose Length: 5mtr
Nozzle:Adjustable Nozzle
Maximum Inlet Temperature:50°C
Engine Type:.....4 Stroke, Single Cylinder, Petrol
Engine Capacity: 196cc
Engine Power6.5hp
Starting:.....Recoil
Fuel Tank:4ltr
Fuel Consumption: 2.1 - 2.6ltr/hr
Weight:36kg
Noise Level:..... 109dB(A)
Engine OilSAE10W-40
Pump Oil:.....SAE15W-40

4. ASSEMBLY / PRE-OPERATION

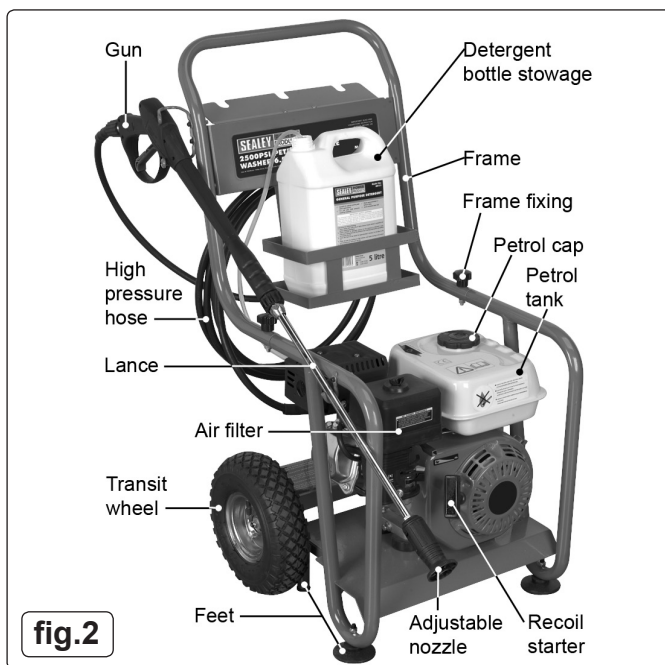
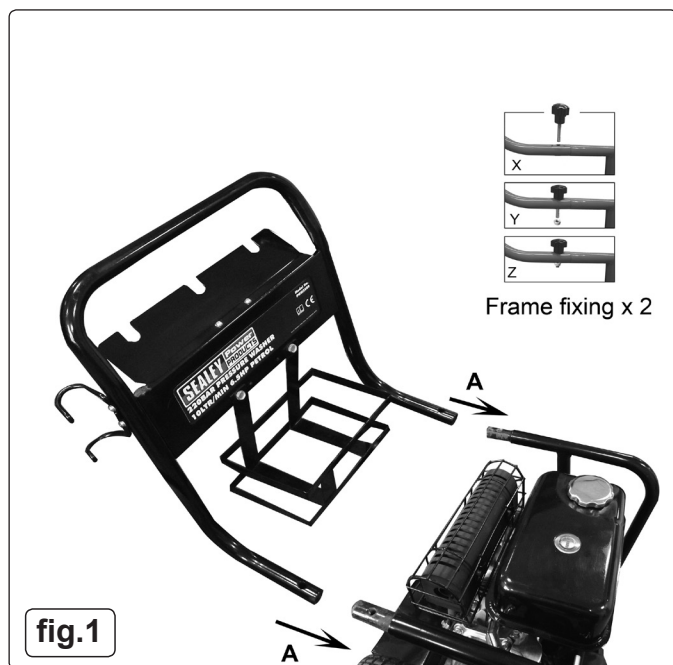

Unpack contents and check to ensure all parts are in good condition. If you experience any problems contact your dealer immediately.

4.1. ASSEMBLY.

- 4.1.1. Attach the upper frame to the lower frame by pushing it onto the spigots protruding from the lower frame as indicated at 'A' in fig.1 above. Ensure that the holes in the ends of the upper frame align with the holes in the spigots. Secure the two parts of the frame together by screwing a frame fixing through each joint as indicated in the inset pictures (fig.1X&Y). Tighten both fixings by hand using the black knobs. Lock each fixing using a nyloc nut applied to the thread protruding from the underside of each joint. (fig.1Z)
- 4.1.2. Slide each wheel onto the axle stubs and retain with a washer and 13mm nut.
- 4.1.3. Screw together the two halves of the lance as shown in fig.3.
- 4.1.4. Attach the high pressure hose to the water inlet on the gun handle as shown in fig.4A and B.
- 4.1.5. Attach the other end of the high pressure hose to the pump outlet as shown in fig.5.
- 4.1.6. Connect the mains water supply hose to the pump inlet as shown in fig.5. **USE COLD WATER ONLY.**

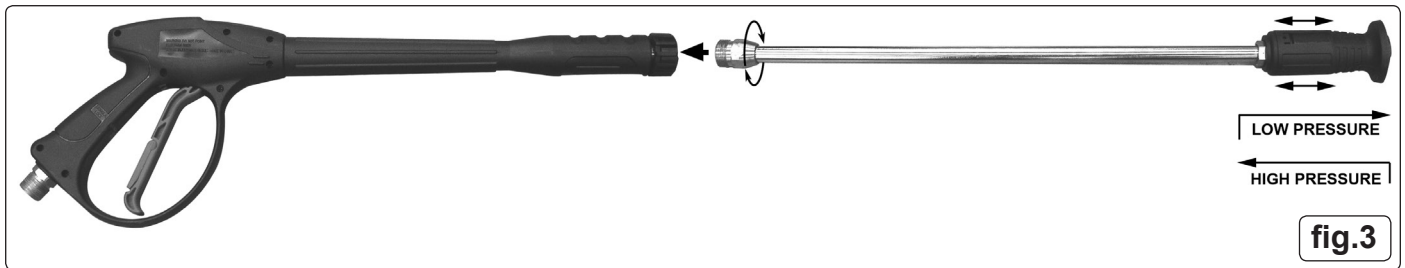

fig.3

Note: The water supply hose must be reinforced and have an internal diameter of 13mm (1/2"). The minimum water supply rate must be at least equal to the washer flow rate.

- 4.2. DETERGENT DELIVERY.
 - 4.2.1. Remove the cap from a bottle of detergent and place the bottle into the stowage frame as shown in fig.2.
 - 4.2.2. On the top of the pump outlet is a brass siphon injection fitting. Push the detergent input pipe onto the fitting (fig.5) and place the filter on the other end into the container of detergent. When the nozzle on the lance is set to low pressure, detergent will be drawn from the container and will mix automatically with the water from the pump. Use Sealey General Purpose Detergent, AK130 (25ltr) or AK131 (5ltr). Traffic Film Remover is also available, AK132 (25ltr) or AK133 (5ltr).
- 4.3. NOZZLE CONTROL.
 - 4.3.1. PRESSURE. To change from high pressure to low pressure the whole nozzle moves backwards and forwards by about 8mm on the end of the lance. Pull the nozzle back towards the handle for high pressure and push it away from the handle for low pressure (see fig.3).
 - 4.3.2. SPRAY PATTERN. To change the spray pattern from a pencil jet to a fan jet rotate the nozzle as shown in fig.6.
- 4.4. ENGINE LUBRICATION.
 - 4.4.1. The pressure washer engine is shipped from the factory without oil. Do not attempt to start the engine before the sump has been filled with the correct amount of oil. Refer to the section 8.2.
- 4.5. FUEL.
 - 4.5.1. Fill the petrol tank with fresh unleaded petrol. Keep fuel level on or below the fuel level indicator in the fuel filter which sits in the neck of the tank.

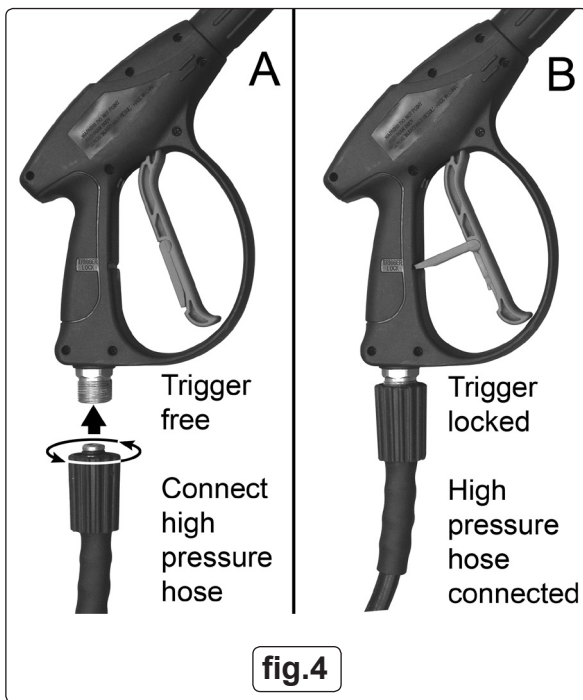

fig.4

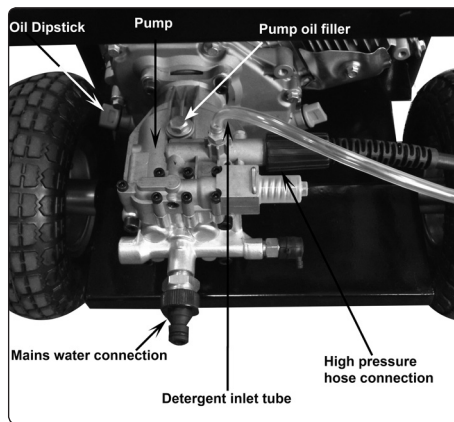

fig.5

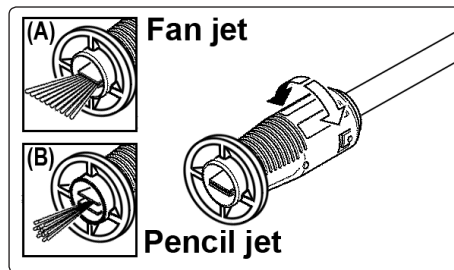

fig.6

5. SAFETY FEATURES

- 5.1. THERMAL RELIEF VALVE.
 - 5.1.1. A thermal relief valve is fitted to protect the machine from overheating if the gun remains closed for an extended period of time or if the nozzle becomes blocked. To prolong the life of the washer every effort should be made to avoid overheating. It is recommended that if the unit is not to be used for two minutes or more it should be switched off.
- 5.2. TRIGGER LOCK.
 - 5.2.1. To prevent accidental starting of the pressure washer the trigger can be locked as shown in Fig.4B by hinging out the lever built into the back of the trigger and pressing it until it snaps into an indent in the handle. To release the locking lever flex the trigger handle forwards and flip the lever out of the indent and fold it back into the trigger. The trigger should be locked whenever the washer is not in use.
- 5.3. LOW OIL SHUTDOWN.
 - 5.3.1. The engine on this washer is equipped with a low oil shutdown feature which stops the engine if the oil drops below the specified level. Should the engine cut out, first check that it is standing on a level surface. If the oil level is still low top it up as described in Section 8.2.

6. OPERATION

- ❑ **WARNING! THE PRESSURE WASHER ENGINE IS SHIPPED FROM THE FACTORY WITHOUT OIL.**
- ❑ **WARNING! RISK OF FLUID INJECTION.** This washer operates at fluid pressures and velocities high enough to penetrate human and animal flesh. If there is an occurrence of fluid injection seek medical help immediately.
- ❑ **WARNING! Ensure you read, understand and apply Section 1 safety instructions.**
- ❑ **WARNING! Dry running can seriously damage the unit.**
- ❑ **WARNING! DO NOT leave motor running for more than 2 minutes without operating the trigger, as temperature/pressure increase may damage sealing system.**

6.1. STARTING PROCEDURE.

- 6.1.1. Check engine oil level before each use.
- 6.1.2. Check that the mains water feed hose is laid straight, and then fully open the water tap. Check to ensure there are no leaks from hoses or connections.
- 6.1.3. Place the detergent input tube into the detergent container (fig.2) Ensure that the filter goes to the bottom of the container.
- 6.1.4. Release gun trigger safety catch and depress trigger to allow any air left in the system to escape, hold for 10 seconds and release.
- 6.1.5. Rotate the engine switch clockwise to the ON position. See fig.7.
- 6.1.6. Fig.8 shows the fuel tap in the OFF position. Push the fuel tap lever to the right to the ON position.
- 6.1.7. If starting the engine from cold move the choke lever fully to the left. Fig.8 shows the lever in the OFF position.
- 6.1.8. Fig.8 shows the throttle lever in the slow running position. Move the throttle lever to the left by a small amount.
- 6.1.9. To start the engine give a steady pull on the starting handle whilst keeping the trigger pressed until the engine starts and water flows from the nozzle.
- 6.1.10. As the engine warms up move the choke lever right into the 'run' position.
- 6.1.11. Adjust the speed of the engine using the throttle lever.

6.2. NOZZLE SPRAY ADJUSTING (fig 6).

Adjust the nozzle pressure and spray pattern as described in section 3.3.

- ❑ **CAUTIONS!**
 - a) Avoid sudden bursts of water as this will cause the water pressure to drop and put extreme pressure on the hoses and connections.
 - b) If another person is using water from the same supply as the washer, the water pressure will drop and correctly. Switch the engine off immediately and wait until the pressure is restored.

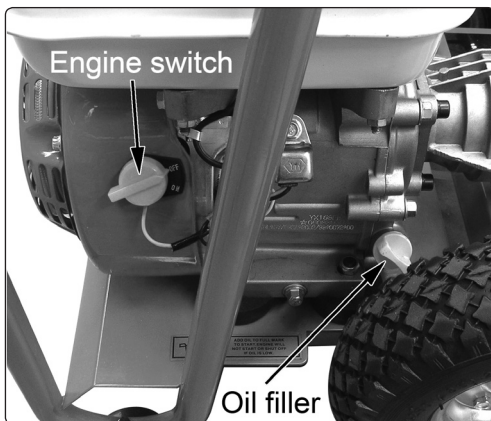

fig.7

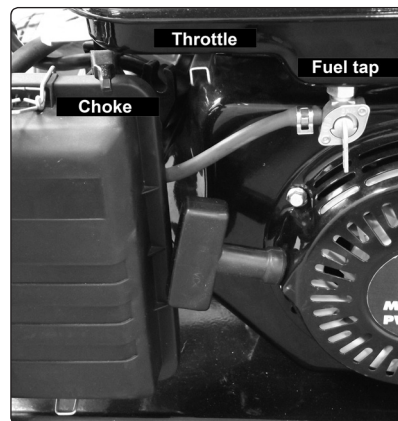

fig.8

6.3. CLEANING

- 6.3.1. Push nozzle forward - LOW PRESSURE - and rotate to fan jet. Only apply detergent at the low pressure rate.
- 6.3.2. Depress the trigger to apply the detergent to the dry surface which is to be cleaned. Vertical surfaces must be cleaned from the bottom upwards.
- 6.3.3. When detergent application is complete remove the syphon tube from the detergent container and place it in a container of clean water. Run the washer at low pressure to purge the gun of detergent.
- 6.3.4. Leave the detergent to act for 1-2 minutes, but do not allow the surface to dry.
- 6.3.5. Pull nozzle back - HIGH PRESSURE - and use fan or pencil jet for washing.
- 6.3.6. Hold nozzle firmly at least 30cm (12") from the surface and commence washing with high pressure clean water. Work from the bottom upwards, and avoid the water running on to unwashed surfaces.

6.4. SHUT DOWN PROCEDURE.

- 6.4.1. When you have finished washing, move the throttle lever to the right to the slow running position.
- 6.4.2. Turn off the engine switch and close the fuel tap. Turn off the mains water supply.
- 6.4.3. Discharge residual pressure from the washer by pressing the trigger until no more water comes out of the nozzle.
- 6.4.4. Engage the trigger safety catch, wipe the washer and store in a dry, safe, childproof area.

6.5. TRANSIT.

- 6.5.1. In the upright position the washer stands on four feet and the two wheels are off the ground. The front feet have suckers attached which help to eliminate creep. The rear feet are out of sight between the wheels. To move the unit tip it backwards on the rear feet until the wheels make contact with the ground. Keep the unit well tipped back as you move it.

7. MAINTENANCE - WASHER

Maintenance should only be performed with the engine turned off and the unit disconnected from the mains water supply.

- 7.1. Clean gun nozzle with a suitable rigid piece of wire (fig 7). Detach lance from gun, remove any dirt from the nozzle head and rinse with clean water. If this does not improve the flow from the nozzle it should be replaced.
- 7.2. Check and clean the water inlet filter every 50 operating hours. The filter is moulded into a rubber washer. Unscrew the brass connector from the black fitting on the water inlet on the pump. Push the black fitting backwards which will eject the filter/washer and then clean the filter washer. If the filter is damaged in any way it should be replaced.
- 7.3. Check and clean the detergent filter at the end of the detergent input tube on a regular basis.
- 7.4. Check the pump oil level by removing the pump filler cap (fig.5). The pump should be topped up with 15w-40oil (the oil capacity of the pump is 0.4ltr).
- 7.5. WINTER STORAGE
 - 7.5.1. Fill the pump with an antifreeze mixture before storing in a frost free, safe, dry area for the winter. Introduce the antifreeze by the following method.
 - 7.5.2. Shut off the water supply and disconnect the supply hose. Relieve pressure within the pump by squeezing the gun trigger. Remove the high pressure hose and let all water drain from it. Hold gun/lance with nozzle downwards and pull trigger until all water has drained out.
 - 7.5.3. Disconnect the ignition lead from the spark plug.
 - 7.5.4. Connect a short length of garden hose to the water inlet and using a funnel pour an antifreeze mixture into it.
 - 7.5.5. Pull the recoil starter several times to circulate the antifreeze through the pump. Continue to add antifreeze and pull the recoil until antifreeze is expelled from the pump.

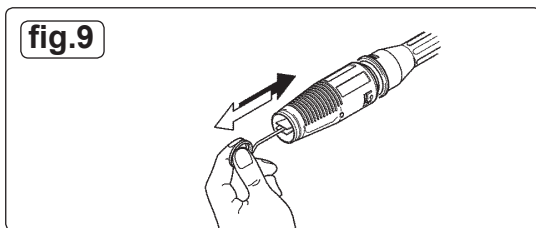

8. MAINTENANCE - ENGINE

- 8.1. Change engine oil after the first 8 hours of operation. Thereafter, change oil monthly or every 50 hours of operation. Change oil more often if engine is operated under heavy load, or in high ambient air temperatures. During normal operation, partially burned fuel, small particles of metal from the cylinder walls, pistons, bearings and combustion deposits will gradually contaminate the oil. If the oil is not changed regularly, these foreign particles can cause increased friction and a grinding action which shortens the life of the engine. Fresh oil also assists in cooling. Old oil gradually becomes thick and loses its cooling ability as well as its lubricating qualities.

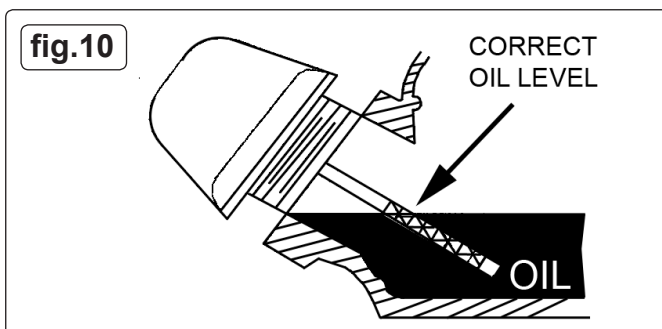

- 8.2. CHECKING THE OIL LEVEL. Ensure the unit is on a level surface.
 - 8.2.1. Unscrew the dipstick and wipe it clean of oil. Note that the maximum oil level should be just below the opening of the filler neck.
 - 8.2.2. Check the oil level by seating the dipstick into the hole without screwing it in. See fig.8 above. If there is no oil on the dipstick when it is removed the level is too low and should be topped up immediately with an SAE10W - 40 oil.
 - 8.2.3. Top up oil if necessary and recheck level.
 - 8.2.4. Screw dipstick fully home to seal oil fill hole.

Note: The engine is fitted with a low oil sensor which will automatically shut the engine down in a low oil situation. The sensor may also operate if the unit is not on a level surface.
- 8.3. ENGINE STORAGE. If the unit is not to be used for more than one month the following procedure should be followed.
 - 8.3.1. Top-up engine oil to maximum.
 - 8.3.2. Drain petrol from the fuel tank, fuel line, fuel tap and carburettor.
 - 8.3.3. Pour one teaspoon of engine oil through the spark plug hole, pull the recoil starter several times and replace the spark plug. Then pull the starter slowly until an increase in pressure is felt indicating that the piston has commenced its compression stroke and leave it in this position. This closes both the intake and exhaust valves and prevents the inside of the cylinder from rusting.
 - 8.3.4. Cover the unit and store it in a clean dry place that is well ventilated and away from open flame or sparks.
- 8.4. AIR CLEANER. The air cleaner is situated below the fuel tank (see fig.2.) To access the air cleaner elements, unclip the over- centre clips at the top and bottom and remove the black cover to reveal the foam pads as shown in fig.11.
 - 8.4.1. Remove the foam pads from the air cleaner housing.
 - 8.4.2. Wash the foam pads with a household detergent or a high flash-point solvent and squeeze dry.
 - 8.4.3. Refit the two foam pads (coarse pad outermost) into the location and bed down.
 - 8.4.4. Replace air filter casing lid and secure with both over-centre clips.



fig.11



fig.12

- ❑ **WARNING!** Petrol is extremely flammable and potentially explosive. Do not perform maintenance on petrol associated components where there is any source of ignition present such as cigarettes, sparks, naked flame or hot surfaces.
- 8.5. MAINTENANCE SCHEDULE.
- 8.5.1. Before each use.
Check engine oil level.
Inspect the unit for evidence of oil and fuel leaks.
- 8.5.2. After the first month or 20 hours only.
Change the engine oil.
Check pump oil
Every 50 hours.
Change the engine oil.
- 8.5.3. Every 6 months or 100 hours.
Change the engine oil.
Check pump oil
Inspect and clean air filter.
Clean the deposit cup.
Clean spark plug and check gap.
- 8.5.4. Every 300 hours.
Replace air cleaner element.
Check valve clearances.
Check idling speed.
Clean spark plug and check gap.
Clean fuel tank fuel filter.

9. TROUBLESHOOTING

Problem	Possible	Remedy
Engine will not start	Low oil sensor has shut down engine	Top up oil to correct level
	Engine switch not in the ON position	Turn switch ON
	Pressure build-up in pump	Operate trigger
Engine is overloaded	Nozzle partially blocked	Clean nozzle
	Excessive pressure build-up	Return to dealer to have reflux valve adjusted
Engine running but pump not building maximum pressure or has irregular pressure	Mains water turned off	Turn on mains water
	Unit has been stored in freezing temperatures	Thaw out completely including hose, gun and wand
	Inadequate water supply	Minimum required is 10ltr/min at 20psi
	Water inlet filter clogged	Clean filter
	Kink in water supply hose	Straighten hose
	Wand nozzle worn or damaged	Replace nozzle
	Air in pump	Run unit with gun open and wand removed until air is purged
	Suction or discharge valve clogged or worn out	Clean suction or discharge valves
	Bypass valve not operating effectively	Clean bypass valve
No intake of chemicals	Injection tube not properly attached to unit	Push tube firmly onto siphon nozzle
	Tube cracked or split	Replace tubing
	Nozzle set to high pressure	Move nozzle to low pressure position
	Siphon nozzle blocked	Clean nozzle
Trigger will not move	Trigger lock engaged	Release trigger lock
Water in crankcase	High humidity	Change oil more frequently
	Worn seals	Return to Sealey dealer for seal replacement
Noisy operation	Worn bearings	Return to Sealey dealer for bearing replacement
	Air mixed with water	Check inlet line for correct size or restriction
Rough/pulsating operation with pressure drop	Inlet restriction	Check for incorrectly sized plumbing, air leaks, or blockages
	Air mixed with water	Check inlet line for correct size or restriction
High crankcase temperature	Wrong grade of oil	Use recommended oil
	Oil level too high / low	Adjust oil level to recommended

Note: It is our policy to continually improve products and as such we reserve the right to alter data, specifications and component parts without prior notice.

Important: No Liability is accepted for incorrect use of this product.

Warranty: Guarantee is 12 months from purchase date, proof of which is required for any claim.



ENVIRONMENT PROTECTION

Recycle unwanted materials instead of disposing of them as waste. All tools, accessories and packaging should be sorted, taken to a recycling centre and disposed of in a manner which is compatible with the environment. When the product becomes completely unserviceable and requires disposal, drain any fluids (if applicable) into approved containers and dispose of the product and fluids according to local regulations.



WEEE REGULATIONS

Dispose of this product at the end of its working life in compliance with the EU Directive on Waste Electrical and Electronic Equipment (WEEE). When the product is no longer required, it must be disposed of in an environmentally protective way. Contact your local solid waste authority for recycling information.

Sealey Group, Kempson Way, Suffolk Business Park, Bury St Edmunds, Suffolk. IP32 7AR



01284 757500



01284 703534



sales@sealey.co.uk



www.sealey.co.uk