



AUTO DARKENING SOLAR POWERED TRUE COLOUR FLIP UP WELDING HELMET - SHADE 9-13

MODEL NO: **PWH603**

Thank you for purchasing a Sealey product. Manufactured to a high standard, this product will, if used according to these instructions, and properly maintained, give you years of trouble free performance.



IMPORTANT: PLEASE READ THESE INSTRUCTIONS CAREFULLY. NOTE THE SAFE OPERATIONAL REQUIREMENTS, WARNINGS & CAUTIONS. USE THE PRODUCT CORRECTLY AND WITH CARE FOR THE PURPOSE FOR WHICH IT IS INTENDED. FAILURE TO DO SO MAY CAUSE DAMAGE AND/OR PERSONAL INJURY AND WILL INVALIDATE THE WARRANTY. KEEP THESE INSTRUCTIONS SAFE FOR FUTURE USE.

1. SAFETY

NOTE: The Auto-Darkening welding helmet is designed to protect the welders eyes from harmful radiation including visible light, ultraviolet radiation (UV) and infra-red radiation (IR) resulting from certain arc and gas welding processes when used in accordance with user instructions. The helmet comes assembled, but must be adjusted to the fit the user. The delay time, sensitivity and shade number for the application. See the table with recommended shade levels.

- ✗ **DO NOT** place the helmet or the ADF on hot surfaces.
- ✓ Use only at temperatures between -5°C and +55°C (23°F and 131°F)
- ✗ **DO NOT** immerse the filter in water and protect it from contact with liquid and dirt.
- ✓ The material which may contact the wearer's skin can cause allergic reaction.
- ✓ Any welding helmet worn over standard ophthalmic spectacles may transmit impact and create a hazard to the wearer in some circumstances.
- ✗ **DO NOT** use for overhead welding or cutting. If this product is used for overhead welding or cutting operation, the molten metal drop may burn through the helmet and cause injury.
- ✓ Eye protector shall only be used against high-speed particles at room temperature.
- ✗ **DO NOT** use automatic welding filter without a backing ocular.
- ✗ **DO NOT** modify or use replacement parts. This will void the warranty and expose the operator to risk of personal injury.
- **WARNING!** If the auto-darkening filter does not darken when the arc ignites, stop welding immediately. Inspect the ADF and its power supply, and change if necessary.
- ✗ **DO NOT** use any solvents or abrasive cleaning detergent on the filter screen or helmet components.
- ✓ Recommended usage is 4 years. The period depends on various factors such as way of use, cleaning, storage and maintenance.
- NOTE:** Frequent inspections and replace sooner than 4 years if damaged/worn.
- ✓ Always wear safety glasses or goggles under the welding helmet.
- ✓ Wear protective clothing to protect from radiation, burns and spatter.
- ✗ **DO NOT** use for driving/road use.
- ✓ Protectors that have been subject to impact shall not be used, and shall be discarded and replaced.
- ✓ A visual inspection of the product is essential before each use.
- ✓ If the impact level symbols are not equal on both the lens/filter and the frame, then it is the lower level that shall be assigned to the complete protector.
- ✓ The protection marked in accordance with this standard is only provided when all lens and retention components are installed according to the list or other manufacturer's instructions.
- ✓ This product does **NOT** protect against physical or chemical hazards.
- ✓ If the helmet, filter or cover plate is in any way damaged, they must be immediately replaced.
- ✓ Replace the product after a mechanical impact.

2. INTRODUCTION

Fully digital flip up welding helmet and true colour technology give the best possible welding and grinding experience. Featuring an auto darkening lens and separate clear grinding shield. For non-welding tasks simply flip up the lens and flip back down when welding or cutting. Self-locking in the up-right position making non welding tasks easier. High quality variable shade 9-13 lens manufactured and tested to ISO 16321. Fully automatic switching from light to dark on striking arc. Digital control panel easily switches between modes and set delay, sensitivity and shade settings. Also includes memory save function to preset and save up to nine personalised settings. Battery is easily replaceable but has solar back up to prolong the battery life. Suitable for MIG, TIG, MMA, gas welding, cutting and grinding.

3. SPECIFICATION

Model No:	PWH603
Grinding Function:	Yes
Operating Temperature:	-10°C to + 60°C
Operating Time Light/Dark:	0.04-2.0s (Digital Control)
Power:	Lithium Cell Battery
PPE Category:	I
Shade Active:	Weld- 9 -13 Cut- 4-8
Shade Inactive:	3/4
Viewing Area:	108 x 82mm

Auto Darkening Filter Marking

16321 YXE W3/4-8/9-13 V1

3=Light State Scale Number

4-8/9-13=Protection Shade Numbers in Dark State 16321 = EN ISO Standard

YXE= Manufacture Identification

V2=Angle of Dependence Classification

V1=Angle of Dependence Classification

W3/7<14 M YXE V1

M=Manual offset(optional)

Helmet Marking

16321 YXE W14 E 1-M CE UKCA

W = Welding protector

14 = Maximum filter shade number

E= Impact Resistance Level 120m/s

C= Impact Resistance Level 45m/s

1-M applicable head size

CE = European Conformity

Cover Plate Marking

YXE 1 E CE YXE 1 E CE UKCA

1 =Enhanced Optical Performance

E= Impact Level 120m/s

4. ASSEMBLY

4.1. HEADGEAR ASSEMBLY

- 4.1.1. Insert the headgear into the helmet shell, as shown in fig.1.
- 4.1.2. Adjust headgear to make it comfortable (see fig.2-fig.5).
- 4.1.3. Make sure both sides are equally positions for proper use.

4.2. REPLACING AUTO DARKENING WELDING FILTER

- 4.2.1. Remove the front cover and put helmet shell face down.
- 4.2.2. Press both tabs and push to release the ADF.

4.3. REPLACING PROTECTION PLATES

- 4.3.1. If protection plates are in any way damaged, replace immediately. Flip up the cover shell, twist two buckles and change the inner grind cover plate.

4.4. BATTERY REPLACEMENT

- 4.4.1. Remove the ADF cassette.
- 4.4.2. Remove the battery and replace with new.

FIG.1

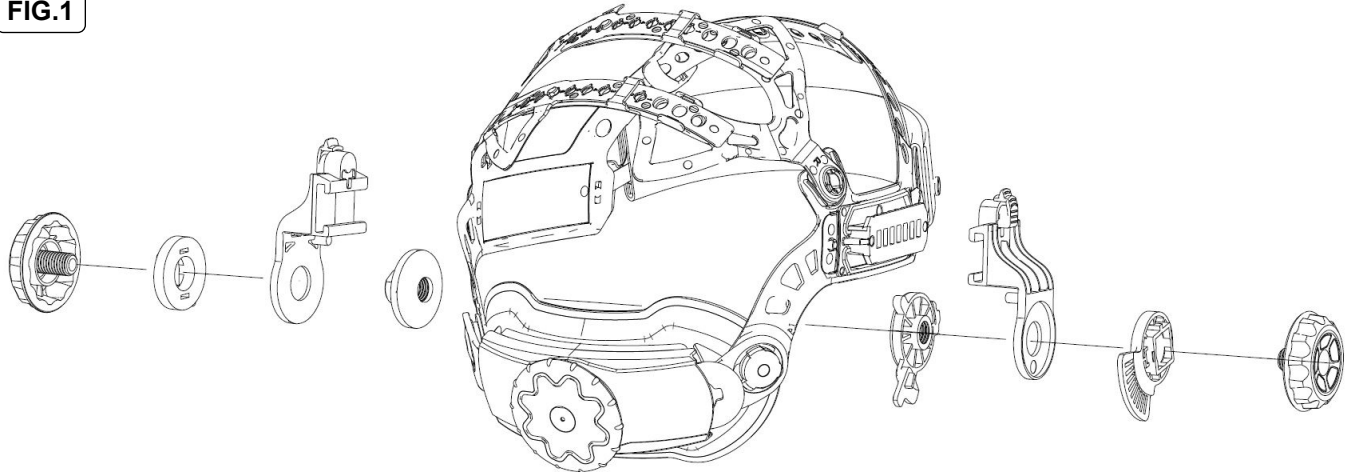

FIG.2

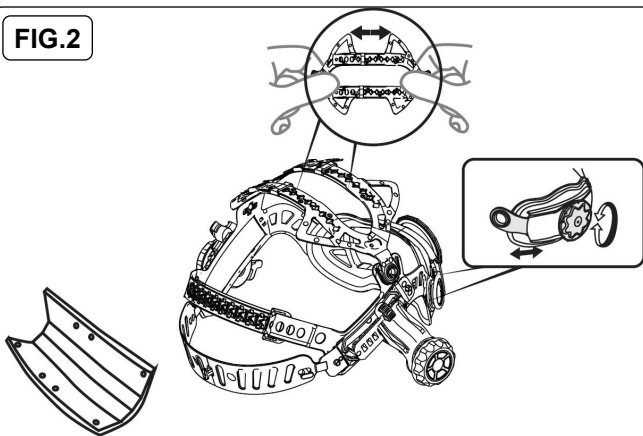

FIG.3

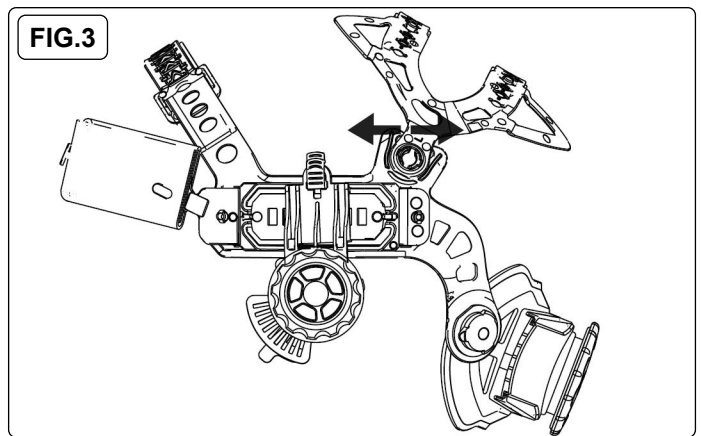

FIG.4

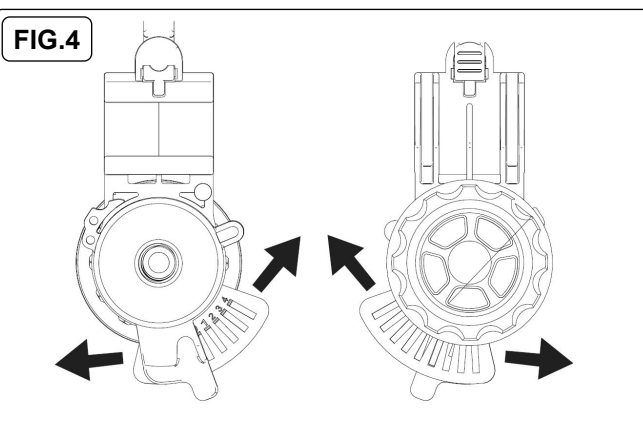
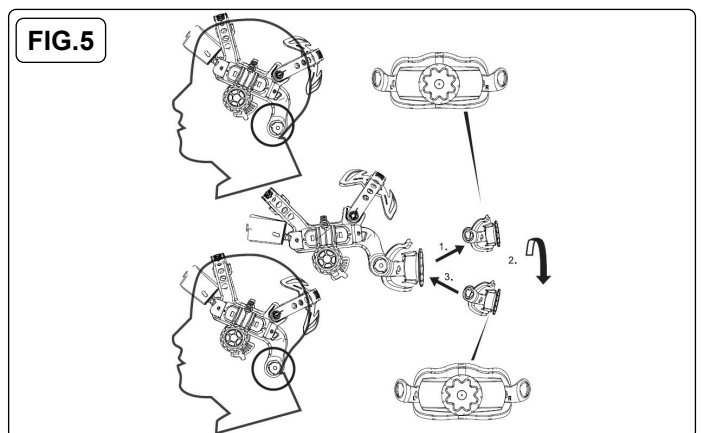

FIG.5



5. OPERATION

5.1. BEFORE USE

- 5.1.1. Remove any additional protective foil from both sides of the PC lens.
- 5.1.2. Make sure there is no dust on any sensor.
- 5.1.3. Set the exact mode you need.

5.1.4. Hold 'mode' or insert battery and the ADF will self-test.

5.1.5. If the battery icon is flashing, change the battery.

5.2. SET THE MODE

The ADF has 4 modes: CUT (4-8), WELD (9-13), GRIND and DARK.

☐ **WARNING! DO NOT** weld in GRIND mode.

5.3. MEMORY MODE

Use the MEMORY and up/down buttons to save settings.

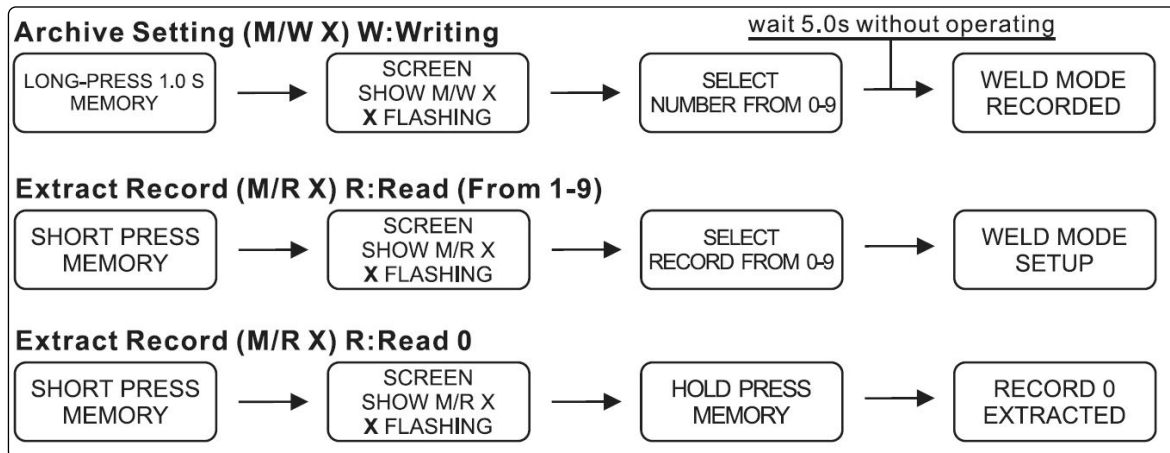

FUNCTION	ADF	OPERATING-UI PANEL	USAGE
Sensitivity	Without Auto Function	Press FUNC. and .	Level 9: for special welding that needs super sensitivity.
	With Auto Function	Press and .	Level 8: for most applications but especially for low current welding work.
		Hold .	Sensitivity is automatically adjusted with deviation ± 2 .
Delay	Without Auto Function	Press FUNC. and .	Level 9: 2.0s is suitable for most applications, especially for high amps current application and longer welding interval.
	With Auto Function	Press and .	Level 1 & 2: suitable for spot welding.
		Hold .	Delay is automatically adjusted with deviation ± 2 .
Shade	Without Auto Function	Press FUNC. and .	Adjust the shade by your experience or according to chart recommended.
	With Auto Function	Press and .	
		Hold .	Shade is automatically adjusted with deviation ± 2 .
	All Series	Hold . Press MODE and select DARK mode. Press simultaneously, main window locked. Hold press , side window locked.	Shade locked at the desired level.
Gradient	Without Auto Function	Hold .	Offering a gradual recovery from dark to light (not suitable for tack mode and spot mode).
	With Auto Function	Press or .	

6. MAINTENANCE

6.1. CLEANING

- 6.1.1. Clean with a damp soft cloth soaked in mild detergent.
- 6.1.2. **DO NOT** use aggressive solvents such as acetone.

6.2. STORAGE

- 6.2.1. Store in a dry place, within the temperature range (-20°C to +70°C).
- 6.2.2. Remove the battery or turn off the ADF before long-term storage.
- 6.2.3. Keep the solar cells of the auto darkening welding filter in the dark to maintain power down mode.
- 6.2.4. Transport in original packaging, away from direct sunlight.
- 6.2.5. **DO NOT** drop or place heavy items or tools on/inside the helmet.

6.3. MAINTENANCE

- 6.3.1. Recommended usage is 4 years. The period depends on various factors such as way of use, cleaning, storage and maintenance.
NOTE: Frequent inspections are recommended. Replace the product sooner than 4 years if damaged/worn.

7. TROUBLESHOOTING

PROBLEM	CAUSE	SOLUTION
Irregular darkening dimming	Headgear has been set unevenly so there is an uneven distance from the eyes to the filter lens.	Reset the headband to reduce the distance to the filter.
Filter does not darken or flickers.	Front cover lens is dirty or damaged.	Clean or replace the cover lens.
	Sensors are dirty/blocked or solar panel is blocked.	Clean and unblock the sensors and solar panel.
	Sensitivity is set too low or delay time is set too short.	Adjust to the required level.
	Make sure the correct shade is selected.	Ensure grind mode has not been selected.
Filter darkens without the arc being struck.	Sensitivity is set too high.	Adjust sensitivity to the required level.
Filter remains dark after completing a weld.	Delay time is set too long.	Adjust delay time to the required level.
Slow response.	Operating temperature is too low.	DO NOT use at temperatures below -10°C or 14°F.
Welding helmet slips.	Headgear is not properly adjusted.	Readjust the headgear.

This document has been drawn up according to Regulation (EU) 2016/425 as amended to apply to GB for Personal Protective Equipment. The declaration of conformity can be accessed at www.sealey.co.uk.



ENVIRONMENT PROTECTION

Recycle unwanted materials instead of disposing of them as waste. All tools, accessories and packaging should be sorted, taken to a recycling centre and disposed of in a manner which is compatible with the environment. When the product becomes completely unserviceable and requires disposal, drain any fluids (if applicable) into approved containers and dispose of the product and fluids according to local regulations.



WEEE REGULATIONS

Dispose of this product at the end of its working life in compliance with the EU Directive on Waste Electrical and Electronic Equipment (WEEE). When the product is no longer required, it must be disposed of in an environmentally protective way. Contact your local solid waste authority for recycling information.



BATTERY REMOVAL

Under the Waste Batteries and Accumulators Regulations 2009, Jack Sealey Ltd are required to inform potential purchasers of products containing batteries (as defined within these regulations), that they are registered with Valpak's registered compliance scheme. Jack Sealey Ltd's Batteries Producer Registration Number (BPRN) is BPRN00705.

Note: It is our policy to continually improve products and as such we reserve the right to alter data, specifications and component parts without prior notice.

Important: No Liability is accepted for incorrect use of this product.

Warranty: Guarantee is 12 months from purchase date, proof of which is required for any claim.

EU | Sealey EU Ltd, Farney Street, Carrickmacross, Co. Monaghan, A81 PK68 Ireland

UK | Sealey Group, Kempson Way, Suffolk Business Park, Bury St Edmunds, Suffolk. IP32 7AR



01284 757500



sales@sealey.co.uk



www.sealey.co.uk